

# **Diamond Calculator 3.2 beta**

**User manual**

7 July, 2009

OctoNus Software

# 1 Content

<b>DIAMOND CALCULATOR 3.2 BETA.....</b>	<b>1</b>
<b>1 CONTENT .....</b>	<b>2</b>
<b>2 WHAT IS DIAMCALC AND WHO BENEFIT FROM IT .....</b>	<b>7</b>
<b>3 WHAT IS NEW IN THE DIAMCALC 3.2? .....</b>	<b>9</b>
3.1 INCLUSIONS RENDERING .....	9
3.2 NON CONVEX (CONCAVE) CUT RENDERINGS ARE SUPPORTED .....	10
3.3 IMPORTING NON CONVEX CUTS FROM BINARY STL .....	10
3.4 STARS EFFECT .....	11
3.5 EXPORT MOVIES FOR IPOD / IPHONE USING DC QUICKTIME EXPORTER .....	12
3.6 CREATING LAYER THROUGH THREE POINTS IN THE CUT DESIGNER .....	14
3.7 NEW BUTTONS UNDO, ReDO AND NEW ARE AVAILABLE IN THE CUT DESIGNER .....	14
3.8 DIAMCALC DEMO VERSION .....	15
3.9 CUSTOM PREFORM / RECUT .....	16
3.10 NEW VIEW MODES ARE AVAILABLE IN THE MAIN DIAMCALC WINDOW.....	17
<i>ETAS and DETAS.....</i>	<i>17</i>
<i>Statistics diagrams.....</i>	<i>18</i>
3.11 NEW PANORAMA ZONES CONTROL.....	19
3.12 ZOOM ZONES CONTROL .....	21
3.13 DISABLE DISPERSION OPTION SUPPORTED FOR HDR IMAGES.....	22
3.14 NEW FEATURES IN IMPORT OF TRANSMISSION SPECTRA .....	24
3.15 10-DEGREE STEP LATITUDE GRIDS FOR THE DETAS GLOBE.....	26
3.16 MAKING PANORAMA, OBSERVER AND PAPER IMAGE LIGHTER OR DARKER BY MULTIPLY COEFFICIENT 27	
<i>Panorama.....</i>	<i>27</i>
<i>Paper image .....</i>	<i>28</i>
<i>Observer.....</i>	<i>28</i>
3.17 LOADING OF DMC FILES WITH DLL CUTTING; AN IMPROVEMENT.....	29
3.18 BATCH CONVERSION TO STL .....	29
3.19 CREATING CUSTOM GIRDLE IN THE CUT DESIGNER .....	30
3.20 GRAYSCALE MODE FOR OBSERVER .....	30
3.21 HIGH-QUALITY RAY TRACING MODES AVAILABLE IN HDR RENDERING.....	31
3.22 JPEG, PNG, BMP, TIFF FILES FORMATS ARE SUPPORTED .....	32
3.23 PAPER AUTO DISTANCE MODE.....	33
3.24 RENDERING OF THE DIAMOND COVERED BY THE PAPER .....	33
3.25 HDR SUPPORTS STANDARD LIGHTS: OFFICE, DISCO, JEWELRY SHOP, ASET AND OTHERS .....	34
3.26 DIFFERENT DEFAULT FILES PATHS FOR DIFFERENT DIALOGS SET BY THE USER .....	34
3.27 SAVING SCALE, STONE ENVIRONMENTS, RENDERING AND MOVIE SETTINGS IN DMC FILE .....	35
3.28 CUSTOM COLOR SPACES FOR HDR IMAGES IS AVAILABLE.....	35
3.29 NEW TONE-MAPPING.....	36
3.30 MEMORY REQUIREMENTS FOR HDR PANORAMAS ARE REDUCED .....	36
3.31 THE REAL RADIUS OF HDR PANORAMA .....	36
3.32 GAMMA CORRECTION FOR HDR IMAGES .....	37
3.33 SCENARIOS .....	37
<b>4 VISUAL PRESENTATION OF A DIAMOND .....</b>	<b>38</b>
4.1 MODEL TYPES (WIREFRAME AND RENDERING).....	38
<i>Draft mode (wireframe).....</i>	<i>39</i>
<i>Photorealistic (standard render).....</i>	<i>39</i>
<i>HDR Photorealistic (hdr image) .....</i>	<i>39</i>
<i>Ray trace.....</i>	<i>40</i>
<i>ETAS.....</i>	<i>41</i>
<i>DETAS.....</i>	<i>41</i>
<i>Statistic diagram.....</i>	<i>42</i>
<i>Draft modes with reflection.....</i>	<i>42</i>



4.2	HDR RENDERING EFFECTS.....	43
	<i>Bloom effect</i> .....	43
	<i>Stars effect</i> .....	43
	<i>Lighting panorama with high dynamic range (HDR)</i> .....	44
	<i>Lighting with generated panorama (zones and light sources)</i> .....	44
	<i>Paper sheet environment</i> .....	45
	<i>Observer model</i> .....	45
4.3	SETTING DIAMOND POSITION .....	46
4.4	SETTING ONE OR TWO SIMULTANEOUS VIEWS OF A DIAMOND.....	47
4.5	SELECTING LIGHT SOURCE .....	48
4.6	EXPORT MOVIES FOR IPOD / IPHONE USING DC QUICKTIME EXPORTER .....	50
<b>5</b>	<b>PHOTOREALISTIC HDR RENDERING OPTIONS.....</b>	<b>52</b>
5.1	GETTING STARTED WITH PHOTOREALISTIC RENDERING OPTIONS .....	52
5.2	THE RENDERING TAB.....	55
	<i>General options</i> .....	55
	<i>Stars Generation</i> .....	56
5.3	THE PANORAMA TAB .....	58
	<i>The Preview window</i> .....	59
	<i>The General group</i> .....	59
	<i>The Lights group</i> .....	60
	<i>The Hemisphere group</i> .....	61
	<i>The External group</i> .....	62
5.4	THE PAPER TAB .....	64
5.5	THE OBSERVER TAB.....	67
5.6	MAKING A SYNTHETIC PANORAMA WITH ZONES .....	72
	<i>Step 1: Beginning</i> .....	72
	<i>Step 2. Configuring zone</i> .....	73
	<i>Step 3. Configuring an inner zone border</i> .....	76
	<i>Step 4. Adding new zones</i> .....	78
	<i>Step 5. Navigate between the zones</i> .....	80
	<i>Step 6. Zoom zones control</i> .....	81
	<i>Step 7. Removing the zone</i> .....	81
5.7	CREATING HIGH DYNAMIC RANGE (HDR) PANORAMA BY THIRD-PARTY SOFTWARE.....	83
	<i>The idea of mapping an image onto the sphere</i> .....	83
	<i>Adobe Photoshop CS3 Extended</i> .....	85
	<i>Adobe Photoshop CS</i> .....	87
	<i>Artizen HDR</i> .....	89
<b>6</b>	<b>CREATING CUTS WITH CUT DESIGNER.....</b>	<b>91</b>
6.1	OVERVIEW .....	91
6.2	GETTING STARTED WITH CUT DESIGNER .....	92
6.3	CUSTOM PREFORM / RECUT .....	95
6.4	CREATING BRILLIANT CUT.....	96
	<i>General settings (as defaults)</i> .....	96
	<i>Cutting Steps</i> .....	96
6.5	CREATING PRINCESS CUT.....	101
	<i>General settings</i> .....	101
	<i>Cutting Steps</i> .....	101
6.6	CREATING GABRIELLE CUT. VARIANT 1 .....	107
	<i>General settings</i> .....	107
	<i>Cutting Steps</i> .....	107



6.7	CREATING GABRIELLE CUT THROUGH THREE POINTS. VARIANT 2 .....	113
	<i>General settings</i> .....	113
	<i>Cutting Steps</i> .....	113
6.8	CREATING EMERALD CUT .....	121
	<i>General settings</i> .....	121
	<i>Cutting Steps</i> .....	121
6.9	SAVE CUT, LOAD CUT AND EXPORT TO DC.....	128
6.10	CREATING CUSTOM GIRDLE .....	130
6.11	CREATING CUSTOM GIRDLE SHAPE BY THIRD-PARTY SOFTWARE .....	134
	<i>Step 1</i> .....	134
	<i>Step 2</i> .....	134
	<i>Step 3</i> .....	135
	<i>Step 4</i> .....	137
<b>7</b>	<b>ESTIMATING WEIGHT OF DIAMONDS.....</b>	<b>139</b>
<b>8</b>	<b>WORKING WITH CUT PARAMETERS .....</b>	<b>142</b>
8.1	PROPORTION AND ADVANCED TABS .....	142
8.2	DUAL PARAMETERS .....	143
8.3	GETTING ADDITIONAL INFORMATION OF PARAMETERS .....	144
8.4	SELECTING UNITS OF MEASUREMENT .....	144
8.5	FINDING UNKNOWN PARAMETERS .....	145
8.6	FIXING PARAMETERS .....	145
<b>9</b>	<b>SUPPORT FOR DIFFERENT CUTS .....</b>	<b>147</b>
9.1	INTERNAL DIAMONDS CUTS .....	147
9.2	IMPORT AND EXPORT EXTERNAL CUTS .....	148
	<i>Import diamond 3D-model from SRN files</i> .....	149
	<i>Import and export DXF files</i> .....	150
	<i>Import and export GemCad ASCII files</i> .....	150
	<i>Import and export STL files</i> .....	151
	<i>Adjusting shape of arbitrary imported 3D model of the diamond</i> .....	151
<b>10</b>	<b>WORKING WITH THE DIFFERENT TYPES OF GEMSTONES .....</b>	<b>154</b>
10.1	SELECT TYPE OF GEMSTONE BUILT-IN DIAMCALC .....	154
10.2	ADJUSTING GEM MATERIAL CHARACTERISTICS.....	154
	<i>The General tab</i> .....	155
	<i>The Refraction tab</i> .....	155
	<i>Absorption tab</i> .....	157
10.3	VISIBLE ADSORPTION SPECTRA AND DIAMCALC-FILES OF COLORED GEM MATERIALS .....	157
10.4	IMPORTING AND ANALYZING TRANSMISSION SPECTRA .....	159
<b>11</b>	<b>CUT QUALITY ESTIMATION .....</b>	<b>161</b>
11.1	LIGHT RETURN .....	161
11.2	LEAKAGE OF LIGHT IN DIAMONDS AND ITS ESTIMATION .....	161
11.3	STEREOVIEW: STEREOVISION AND EVALUATION OF LEAKAGE.....	166
11.4	TAKING INTO ACCOUNT THE FEATURES OF HUMAN PERCEPTION.....	169
	<i>Subjective brightness function</i> .....	169
	<i>Subjective grading function</i> .....	170
	<i>Weighed geometric average function</i> .....	170
11.5	BRILLIANCE .....	171
	<i>Definitions of Brilliance</i> .....	171
	<i>Discussion</i> .....	172
	<i>Here we are posting two following definitions of «Brilliance» for your suggestions</i> .....	172





11.6	CONTRAST .....	173
11.7	DARK ZONE .....	173
11.8	FISH EYE.....	173
<b>12</b>	<b>APPRAISING DIAMONDS QUALITY AND PRICING DIAMONDS.....</b>	<b>174</b>
12.1	HOW DIAMCALC GRADES DIAMONDS .....	174
12.2	HOW DIAMCALC PRICES DIAMONDS.....	175
<b>13</b>	<b>CREATING DIAMOND REPORTS.....</b>	<b>176</b>
13.1	CREATING DIAMOND GRADING REPORTS.....	176
13.2	CREATING REPORTS FOR SCANNED POLISHED DIAMONDS .....	177
	<i>Step-by-step instruction</i> .....	177
	<i>Report templates</i> .....	182
13.3	CUSTOMIZING MS WORD REPORT TEMPLATES .....	183
	<i>Using RTF report templates</i> .....	183
	<i>Using initialization files</i> .....	185
13.4	CUSTOMIZING PRINTING AND VIEWING DIAMCALC REPORTS .....	185
	<i>Keys of the [General] and [FileNames] sections</i> .....	186
	<i>[Picture] section</i> .....	187
<b>14</b>	<b>DIAMOND CALCULATOR FAQ .....</b>	<b>189</b>
14.1	I CAN NOT MAKE A CHANGE OF 1/10 DEGREE WHILE MODIFYING ASCII FILE. IS THERE A WAY TO REFINE THE CHANGE?.....	189
14.2	HOW DO I PLACE A MOVIE RECORDED BY THE DIAMCALC ON A WEB SITE? .....	189
14.3	HOW CAN I MAKE FANCY COLOR PHOTOREALISTIC PICTURES WITH DIAMCALC? .....	189
14.4	WHAT IS SPREAD?.....	189
14.5	WHAT IS AGS SPREAD? .....	189
14.6	WHAT IS GAMMA CORRECTION? .....	190
14.7	WHAT IS THE ACCURACY OF THE DIAMCALC MASS ESTIMATION? .....	190
14.8	WHY DOES THE DIAMCALC VALLEY GIRDLE MEASUREMENT PRODUCE NEGATIVE VALUES FOR VERY THIN AND EXTREMELY THIN GIRDLES, WHICH DOES NOT MATCH ANY CHARTS?.....	190
14.9	HOW TO OPEN GEMCAD GEM FILES IN DIAMCALC?.....	190
14.10	HOW CAN I CONTACT THE DIAMCALC SUPPORT? .....	191
<b>15</b>	<b>DIAMCALC VERSIONS HISTORY .....</b>	<b>192</b>
15.1	DIAMCALC 3.0 - AUGUST 3, 2007.....	192
	1. <i>New features in the photorealistic rendering mode</i> .....	192
	2. <i>ETAS images</i> .....	194
	3. <i>Cut Designer tool builds variable models</i> .....	194
	4. <i>Simulation algorithm for stereoscopic photorealistic view of diamond is improved</i> .....	195
	5. <i>Added Natural Diamond and Cubic Zirconia to the list of materials for setting refraction in Gem properties</i> .....	196
	6. <i>Added the new GIA appraiser for Brilliant cut. It is named GIA_PCT_2006</i> .....	196
15.2	DIAMCALC 2.8.0 (BUILD 375) - SEPTEMBER 11, 2006 .....	197
15.3	DIAMCALC 2.4.0 (BUILD 337) - SEPTEMBER 30, 2005 .....	204
15.4	DIAMCALC 2.3.0 (BUILD 321) - APRIL 20, 2004.....	206
	<i>New features</i> .....	206
	<i>Fixed bugs</i> .....	210
15.5	UPDATED APPRAISER FILE APPRICE.TXT - APRIL 23, 2003.....	211
15.6	DIAMCALC 2.2.1 (BUILD 265) - MARCH 7, 2003.....	211
15.7	DIAMCALC 2.2.1 (BUILD 255) - FEBRUARY 25, 2003.....	211
	<i>New features</i> .....	211
	<i>Fixed bugs</i> .....	211
15.8	DIAMCALC 2.2.0 (BUILD 247) - DECEMBER 10, 2002 .....	212



	<i>New features</i> .....	212
	<i>Bugs fixed</i> .....	213
15.9	DIAMCALC 2.1.1 (BUILD 216) - AUGUST 22, 2002 .....	213
15.10	DIAMCALC 2.1.0 - JULY 28, 2002 .....	214
15.11	DIAMCALC 2.0.1 - MAY 25, 2002 .....	215
15.12	DIAMCALC 2.0 - MARCH 15, 2002 .....	215
15.13	DIAMCALC 1.8.0 - 1.8.3, JULY 2001 - JANUARY 2002 .....	216
15.14	DIAMCALC 1.7.0 - 1.7.5, JULY 2000 - MARCH 2001 .....	216
15.15	DIAMCALC 1.6.0 - 1.6.1, APRIL - MAY 2000 .....	217
15.16	DIAMCALC 1.5.0 - 1.5.1, MARCH - APRIL 2000 .....	218
15.17	DIAMCALC 1.4 .....	219
15.18	DIAMCALC 1.3 .....	219
15.19	DIAMCALC 1.2 .....	219
15.20	DIAMCALC 1.1 .....	219
<b>16</b>	<b>SYSTEM REQUIREMENTS</b> .....	<b>220</b>
<b>17</b>	<b>INFORMATION FOR MAC USERS</b> .....	<b>221</b>
<b>18</b>	<b>APPENDIX</b> .....	<b>222</b>

## 2 What is DiamCalc and who benefit from it

DiamCalc is a system for cut gemstones modeling, which enables many different users to achieve their goals. The real (photorealistic) image of a polished diamond created by the system makes it possible to determine the cut properties that often cannot be measured and to find the optimal combination of cut parameters that would provide the best perception (brilliance, fire, scintillation etc) of the stone.

Photographs do not adequately show the sparkle and brightness of a real diamond; until now. DiamCalc3 has High Dynamic Range (HDR) imaging that shows the intense sparkles on your computer screen by reproducing the flares or bloom that we see in real diamonds. Bright sparkles often appear to be larger than the facet they emanate from, even extending outside the edge of the diamond.

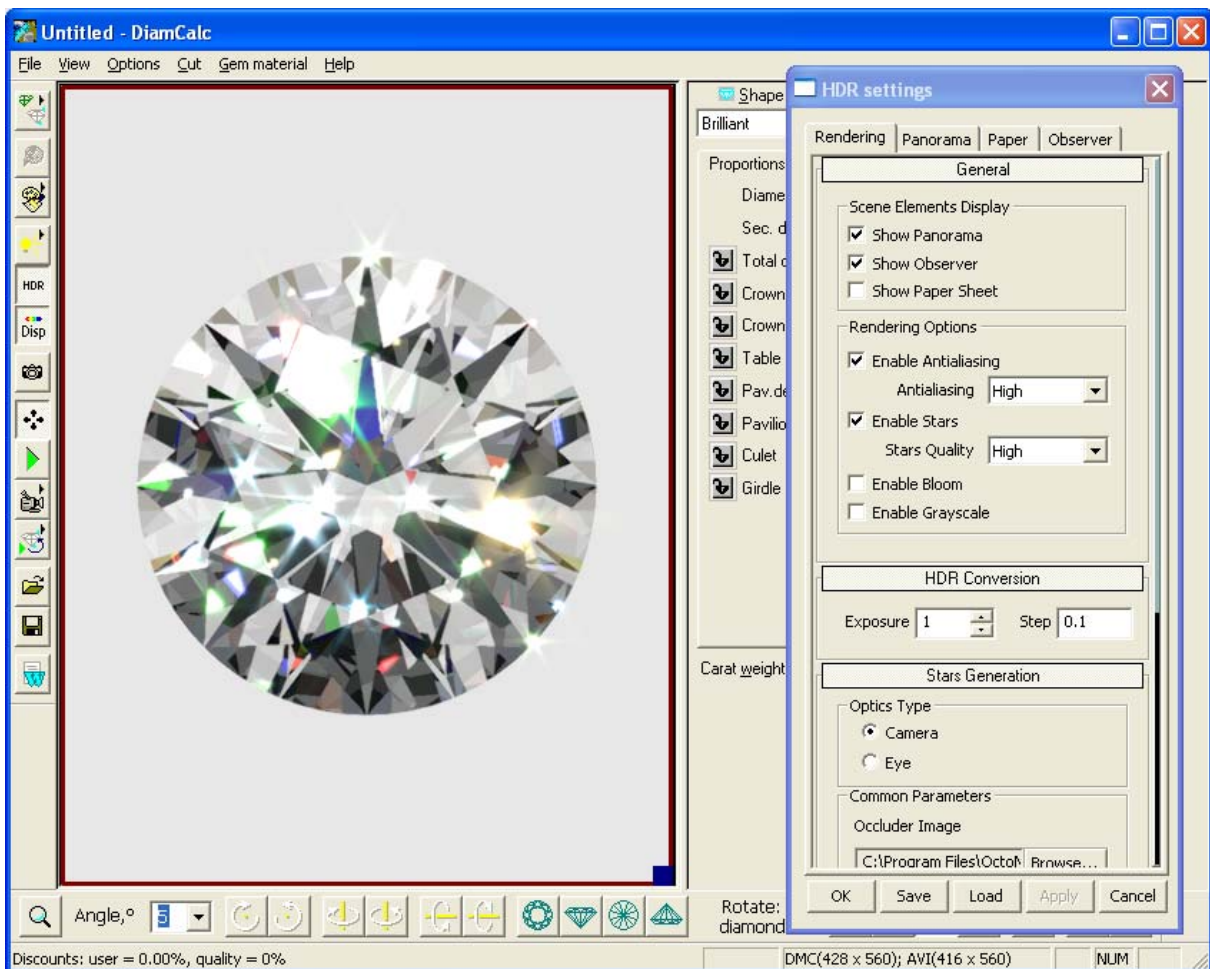

Scintillation is the last great frontier of diamond cut studies. Regular ray tracing software and lab grading systems have failed to model scintillation and capture this *bloom* factor.

Now buyers and sellers can realistically show a client, or visualize a distant diamond themselves before buying it. They can see just how it will look as they rock it from side to side in their own environment and even make promotional videos for individual diamonds.

 [Play five full size DiamCalc 3.2 Demo movies in one window](#)

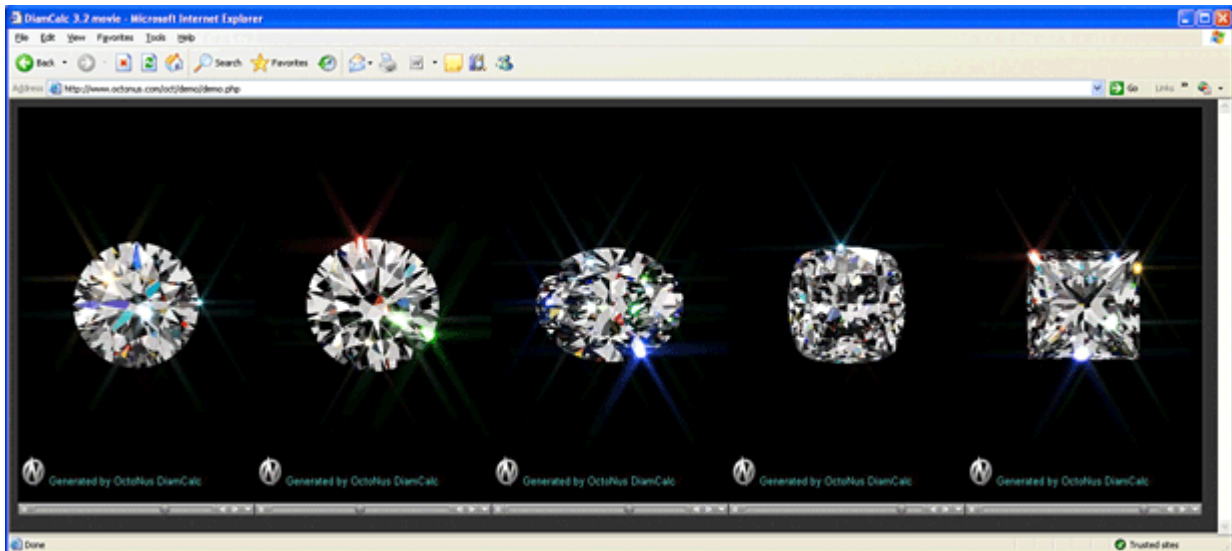

### [More DiamCalc HDR Demo Movies](#)

DiamCalc's High Dynamic Range lighting can come from a variety of panoramas such as a ball room, forest or hillside so anyone can see how the diamond will look in each of these environments. Jewelers of the future will no doubt import panoramic images of their own sales floor into DiamCalc.

The result of new technologies is the highly photorealistic images reflecting both non-trivial optical properties of gemstones and compound features of the environment as shown here where the diamond is positioned above a virtual sheet of paper with a grid pattern.

The Diamond calculator is designed for jewelers, diamond graders, and sale specialists dealing with diamonds and diamond jewelry, for companies active in designing special cuts, manufacturers and technologists.

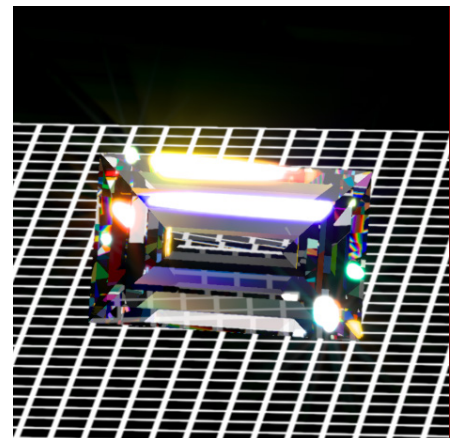



### 3 What is new in the DiamCalc 3.2?

#### 3.1 Inclusions rendering

In this inclusion rendering demonstration, you can see how different types of defects affect the gemstone's appearance.

There are three default defects: a surface reaching large crack and two coupled solid material inclusions. While the appearance of the latter is only affected by the diffuse lighting (depends on panorama in question), the crack also exhibits reflective and transparent appearances depending on the observation parameters.

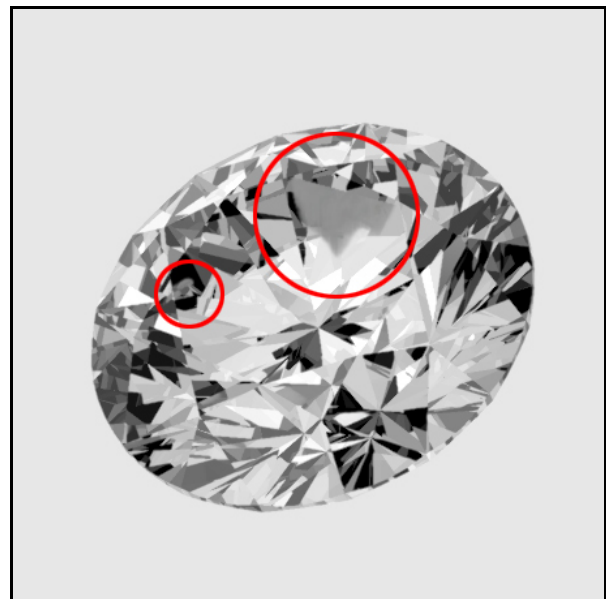
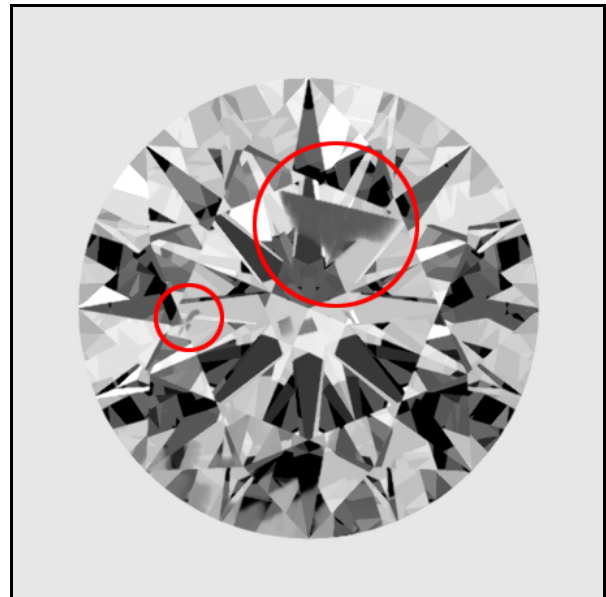
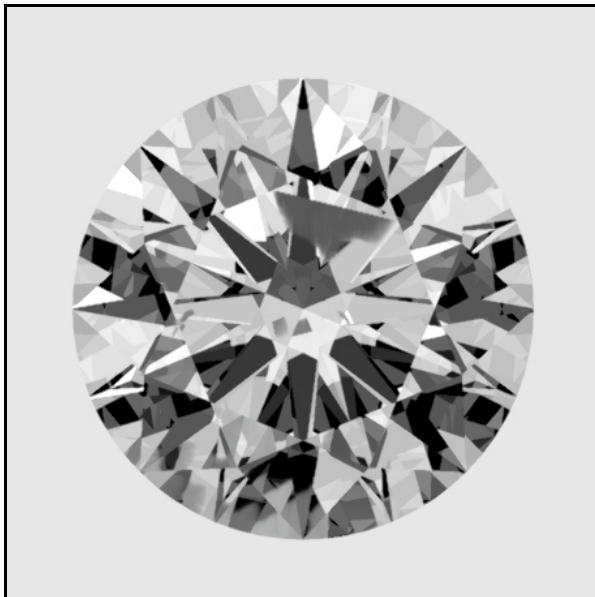

To see inclusions demo select from menu **File / Crack – inclusion demo** in the DiamCalc 3.2 Demo version:

[http://www.octonus.com/oct/download/diam\\_demo\\_down.phtml](http://www.octonus.com/oct/download/diam_demo_down.phtml)



### ***3.2 Non convex (concave) cut renderings are supported***

Now DiamCalc supports photorealistic rendering for concave cuts.

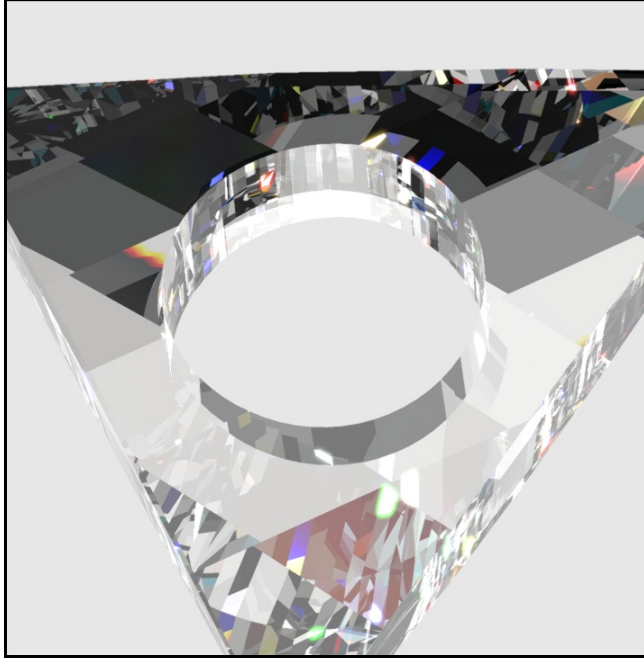

### ***3.3 Importing non convex cuts from binary STL***

Now import for non convex cut is supported from binary STL. Previous versions supported import from binary STL format of convex cuts only.





### 3.4 Stars effect



Stars effect is a feature which appears in real life when a bright object is observed in darkness, and there is an occluder object in front of it.

In case of human eye, eyelashes could be such occluder, producing stars effect. In case of camera, polishing or scratching on the objective causes occludes.

Different occluder images can be chosen from the program kit:

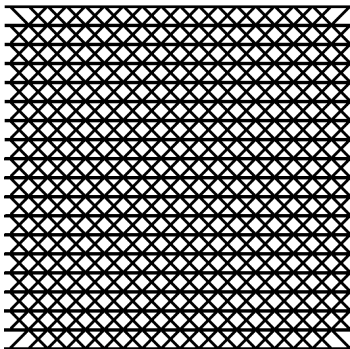

Camera occluder example

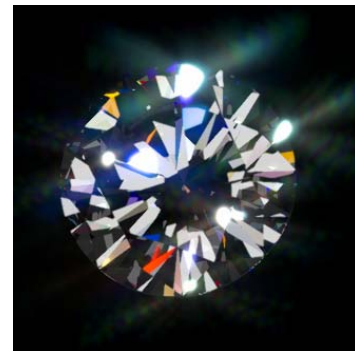
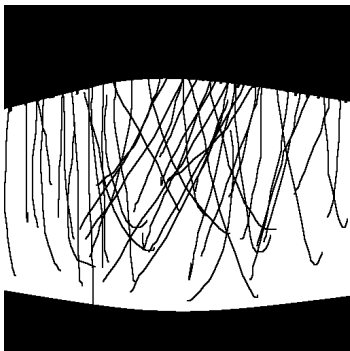

Eyes occluder example

### 3.5 Export movies for iPod / iPhone using DC QuickTime exporter

Export *QuickTime* movies (MOV) for iPod / iPhone is available.

To export QuickTime movie:

- Press button **Movie menu** 
- Choose **Record**:

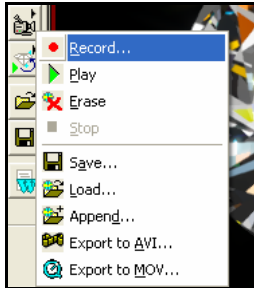

- Set movie recording options

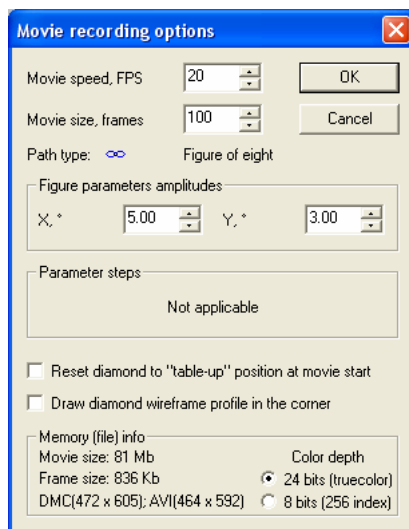

- Press **Ok**
- The recording will proceed. Press **Stop** when movie is ready

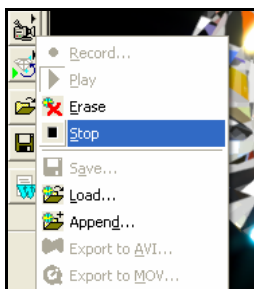



- Choose **Export to MOV...**:

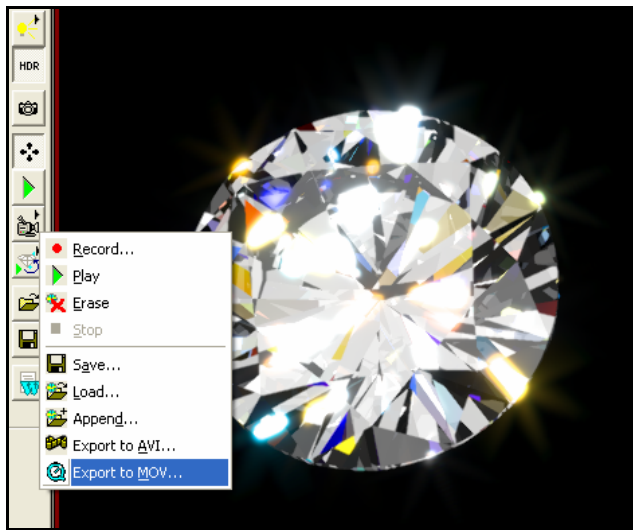

- Save file \*.mov
- Import \*.mov file into your **iTunes**
- Select \*.mov file in iTunes and Right click mouse on it
- Select **Create iPod or iPhone Version** in context menu to convert movie for your iPod / iPhone

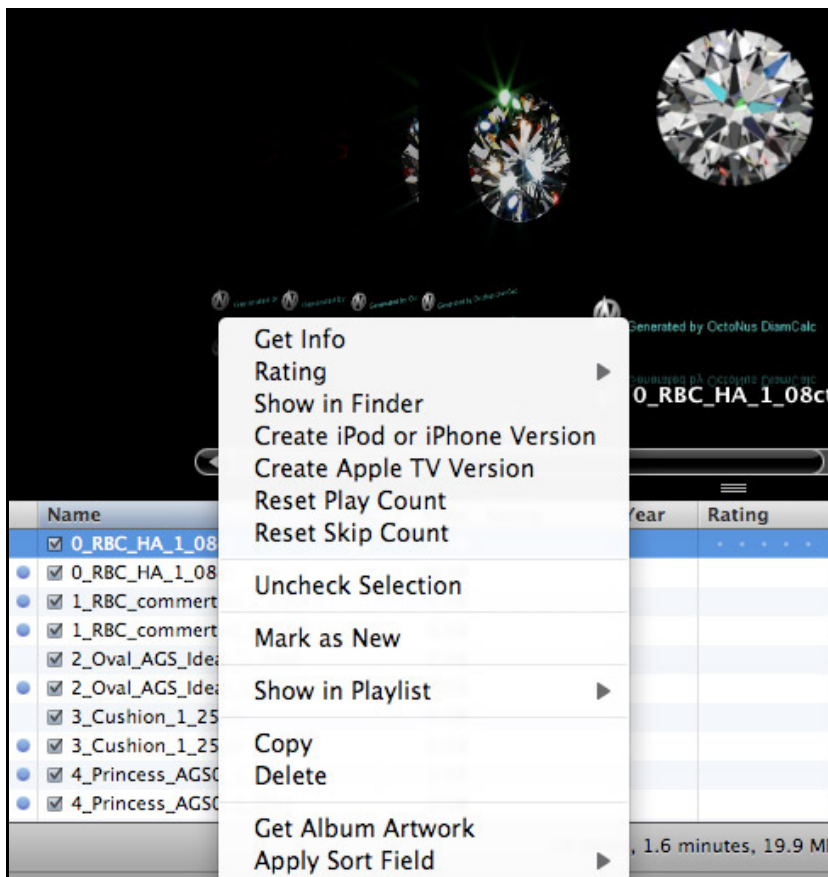

### 3.6 Creating layer through three points in the Cut Designer

Creating layer **through three points** is a new flexible method for creating cut. One of the main advantage of this method is you need not to know and set Gear indexes and slope angles while you create layers of facets. See example in the section **Creating Gabrielle cut through three points. Variant 2**

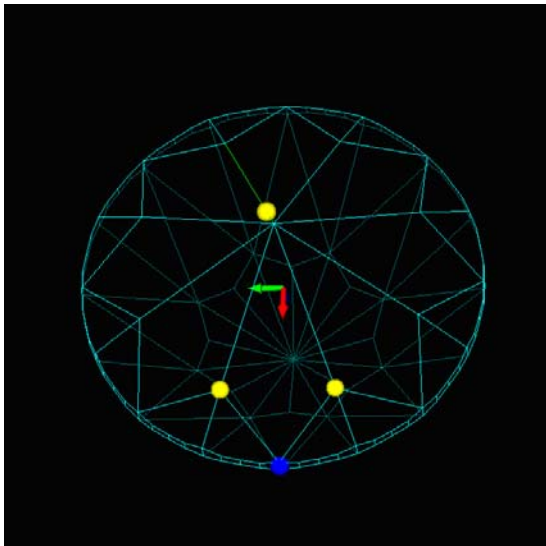

Three points

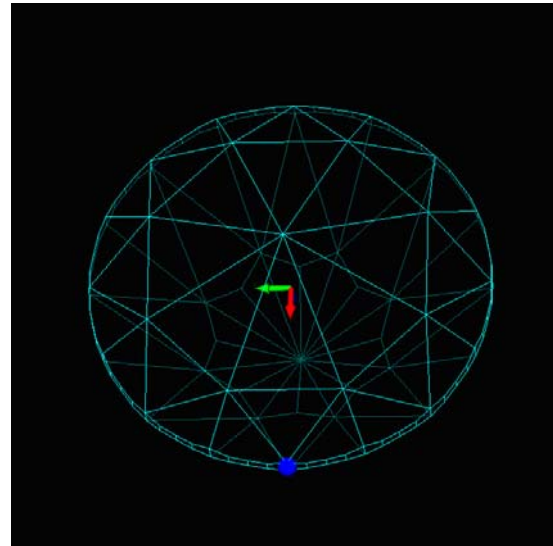

Result of creating layer through three point

### 3.7 New buttons *UnDo*, *ReDo* and *New* are available in the Cut Designer

New buttons **UnDo**, **ReDo** and **New** are available in the Cut Designer main window

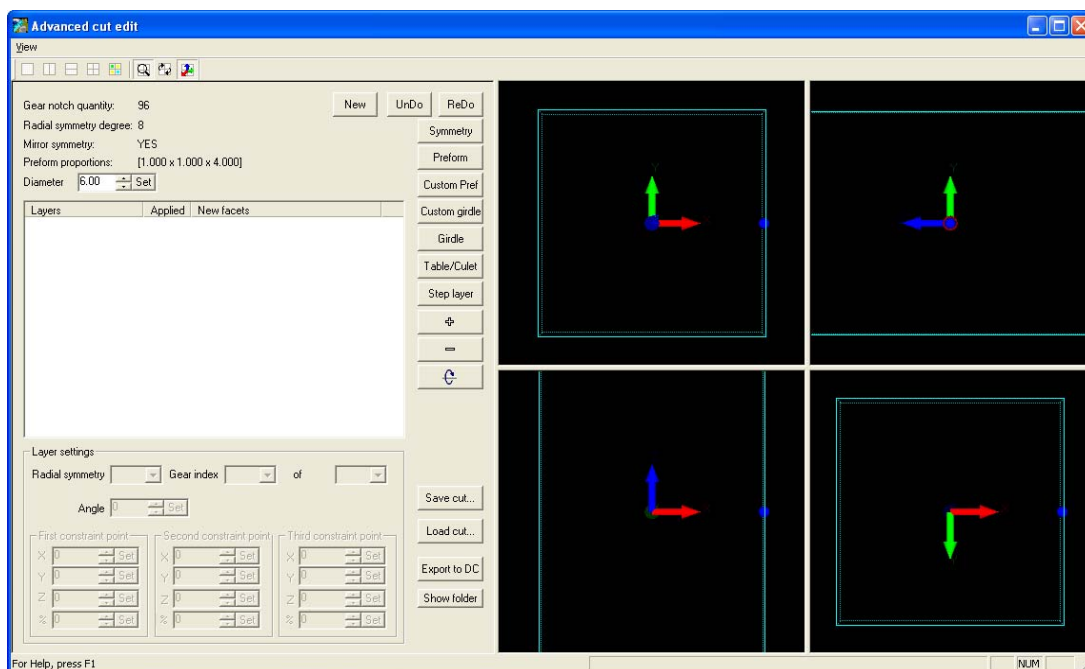

To undo and redo use buttons **UnDo** and **ReDo**



To reset all settings and create new cutting press button **New**



### 3.8 *DiamCalc Demo version*

You may have tried to explain the benefits of DiamCalc to friends and associates. There is a powerful free demo version. It is available for download here: [http://www.octonus.com/oct/download/diam\\_demo\\_down.phtml](http://www.octonus.com/oct/download/diam_demo_down.phtml)

The demo version contains three examples:

- Marquise – parametric cut demo
- Cushion – vivid color demo
- Crack – inclusions demo

To open example select it from menu **Files**:

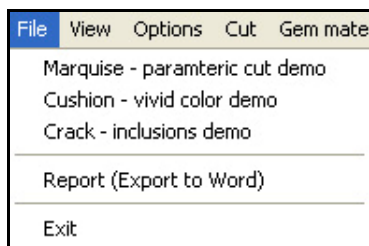

The Demo enables all HDR rendering features for the limited included examples.

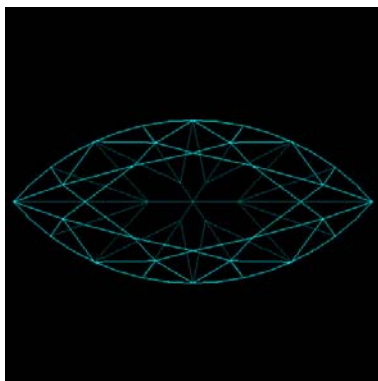

Marquise



Cushion

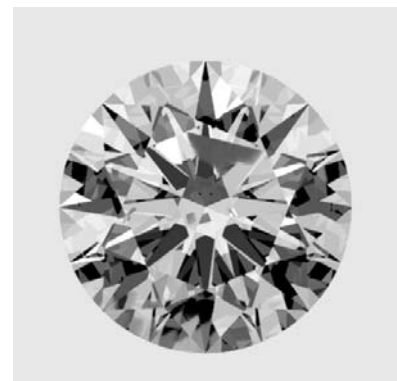

Crack

***Restriction of Demo version:*** files can not be saved and loaded, but the marquise proportions can be adjusted to see how DiamCalc can benefit colour enhancement by controlling the cut. The brilliant that demonstrates the Inclusion viewer however does not enable proportions to be changed.

### 3.9 Custom preform / Recut

Cut Designer allows to start creating cut using arbitrary 3D stone model as a *preform*. It is possible loading preform from DMC, ASCII, scanned MMD and others. This option can be used either for cut creating on the basis of existing cuts or as instrument for recutting design. Especially useful for recutting is the option of viewing the photorealistic image of the stone immediately during editing the model form.

To load preform - any diamonds shape into Cut Designer:

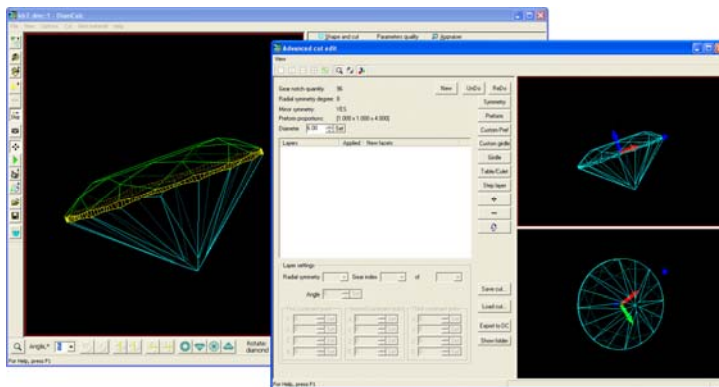

- Open file with desired preform in the DiamCalc main window
- Open Cut Designer
- Press button Custom Preform 
- Desired preform appears in the Cut designer window

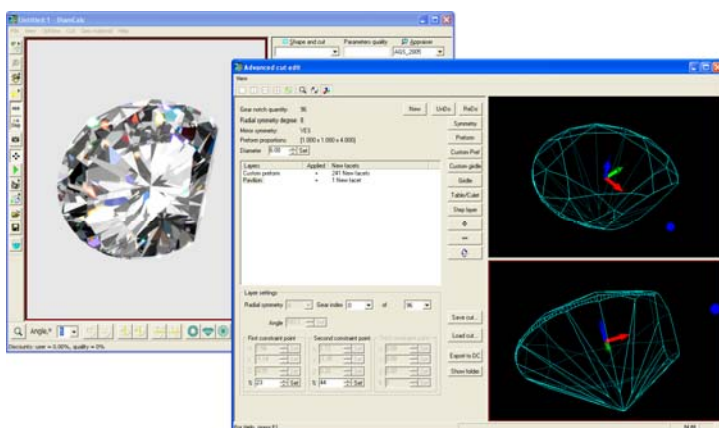

- Now work with loaded preform as usual
- It is possible while working in Cut Designer to view the photorealistic image of edited diamond



#### Restrictions:

- Button **Flip**  does not work with loaded preforms
- Some times using **Step Layer**  provides unexpected results for non convex shapes

### 3.10 New view modes are available in the main DiamCalc window

ETAS, DETAS and Statistics diagrams are now available in the main DiamCalc window.

To open one of the new-added modes press button  and select mode from the list of diamond representation types:

- ETAS\*
- Dynamic ETAS\*
- Ray path statistics diagrams
- Chromatic dispersion statistics diagrams
- Intensity weighted dispersion statistics diagrams

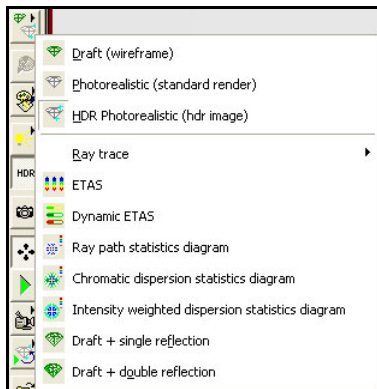

### ETAS and DETAS

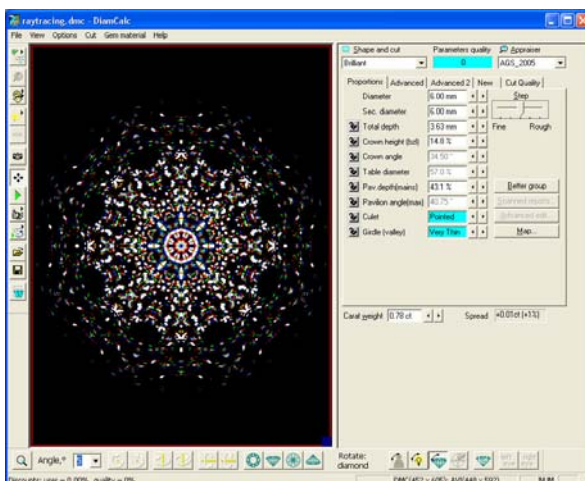

ETAS

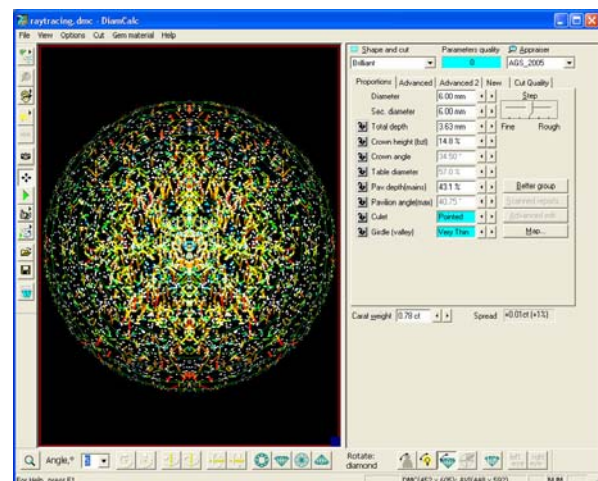

DETAS

\*The ETAS and DETAS was previously displayed only in the panel View HDR Panorama \ ETAS



**ETAS** (Effective Total Angular Size of a diamond) mode indicates the probability for a small light source to be seen through the diamond.

Fire is an estimate of probability for colored dispersed light to be seen due to chromatic dispersion of the light source caused by the crystal.

Light sources are assumed to be located at the sphere of 2000 mm radius around the diamond's center which was chosen as a common distance from the diamond to light sources.

**DETAS** (Dynamic ETAS) mode is ETAS that considers a diamond in motion of 2 degrees of tilt in the north south orientation as if the stone was moved away from the observer. While tilting, a diamond *scans* the space around it, thus increasing the probability to see a light source.

As the diamond is tilted it scans the space around it, thus increasing the probability of seeing a light source.

The stripes in the DETAS are the trails of ETAS spots that crawl across the sphere as the diamond is tilted away by 2 degrees from its initial face up position. The color represents the crawling speed: the faster spot crawls the more reddish is a stripe

Blue color means that the spot doesn't move upon diamond tilting

Green color means that the spot crawls as fast as one from a tilting mirror

Yellow – is a little faster

Red color denotes the fastest spots

Spherical 10-degree step latitude grids are displayed on the DETAS panel along with the marker of space occupied by observer's head indicated by white circle.

## Statistics diagrams

The diagrams show the statistic properties of the light ray's trip across the gemstone crystal in the course of rendering.

The maximum angle of chromatic dispersion is angle weighted with ray energy and average ray path inside the crystal and is represented with different colors for each spot of the diamond picture. This is enabled for all stones and will assist in estimating the potential to see a dispersion feature as the proportions are adjusted (remember that what is shown is a face up view and we actually see two versions of a gem – one with each eye, so we can see twice as many fiery flashes than this mono-scopic view).

Intensity weighted dispersion indicate the intensity of a fiery flash from a spot on the gem. You can see there are flashes with high angular dispersion, red and yellow, in the image on the left that are so widely dispersed that their intensity on the middle image indicates they might be hard to see, especially in a brightly illuminated room.

The third image, on the right, indicates the ray path length as a function of the stones average diameter. Note this is longer in the part of the stone that has many small virtual facets because the ray is bouncing around several times before emerging, a crushed ice appearance, and shorter in the mid section of the stone where much of the light has very few internal reflections.

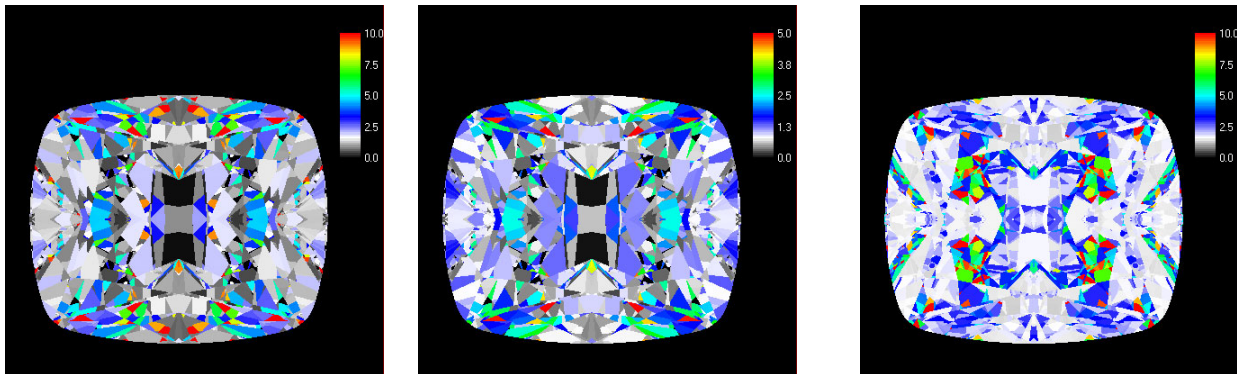

Chromatic dispersion statistics diagram: maximum angle of chromatic dispersion is sampled throughout the diamond picture.

Color band at the right shows the values scale in degrees.

Intensity weighted dispersion statistics diagram: maximum value of the ray's brightness time's its chromatic dispersion angle is sampled throughout the diamond picture.

Color band at the right shows the values scale in degrees times fraction of unity.

Ray path statistics diagram: average path the light ray traveled inside the diamond is sampled throughout the diamond picture.

Color band at the right shows the values scale in units of the diamond's diameter.

### 3.11 New panorama zones control

New options in panorama zones control are available. To modify panorama zones check **Enable Light Hemisphere** in the tab **Panorama** section **Hemisphere**.

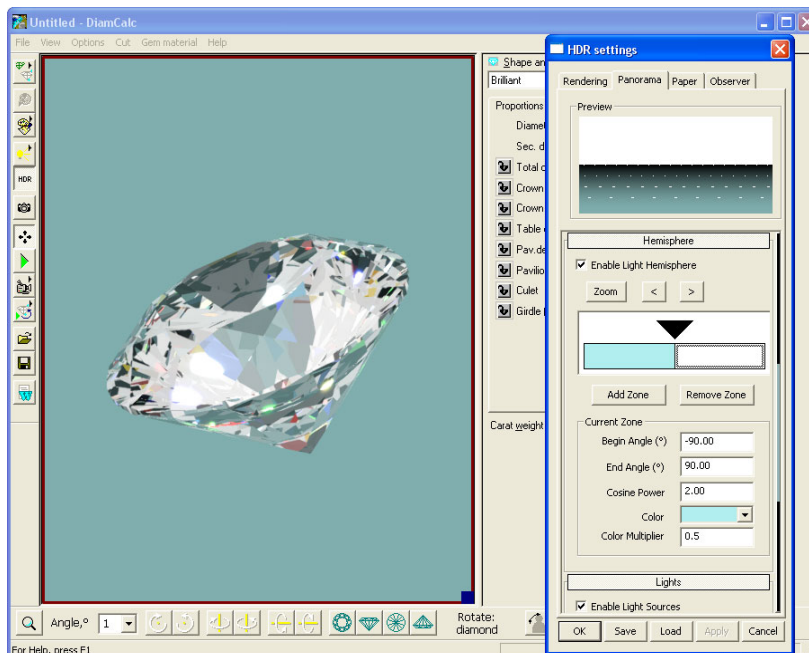



To configure inner zone border:

- Click on triangle ▼ in the zones diagram

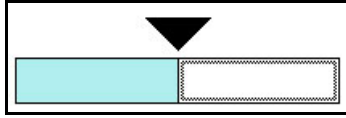

- Move triangle to make the zone smaller or larger

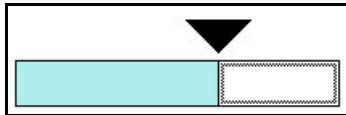

If two triangles are placed close –a number will appear to indicate how many triangles are there in one place

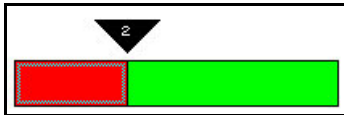

If the borders or the triangles are moved the zone behind these two zones will appear inside

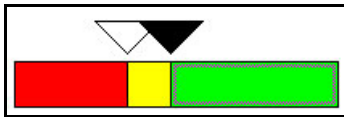

To remove the zone:

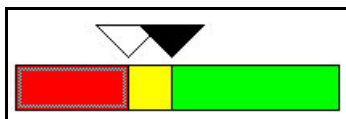

- Left click inside the zone to select it. For example, select red zone:

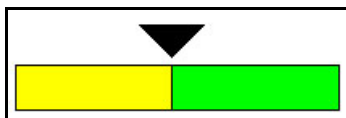

- Press button **Remove Zone** 
- Red zone is removed





To switch between the zones use the new control buttons  

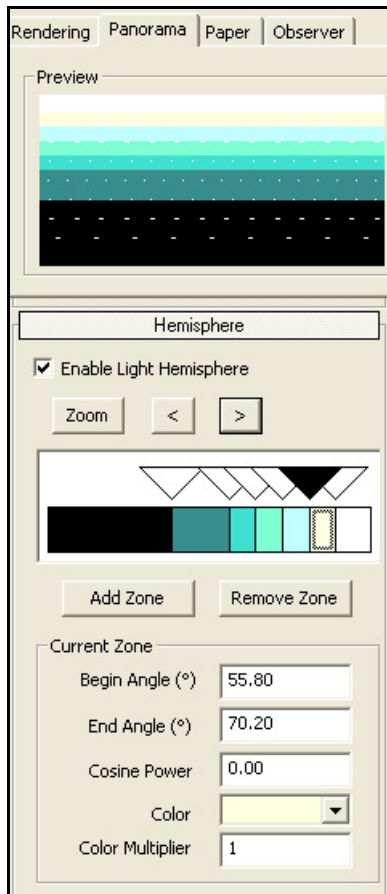

Also use new Hot keys to switch between the zones **Ctrl + >** and **Ctrl + <**

### 3.12 Zoom zones control

Zoom of Zones control section is available. It is useful if there are a lot of thin zones. To zoom Zones control section:

- Press button **Zoom**  in the section **Hemisphere**

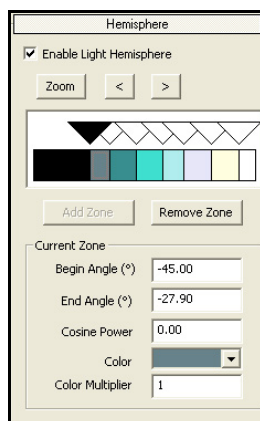

- The new separate window **Light Hemisphere** appears

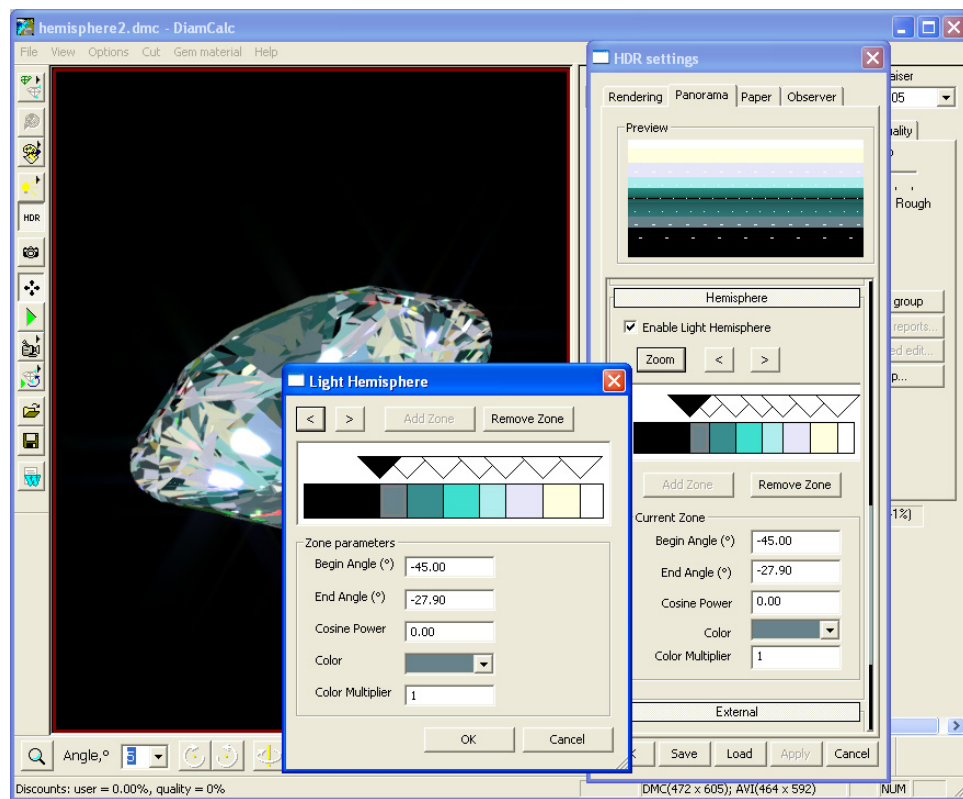

- Make changes in the Zones control
- Press **OK** to apply changes

### 3.13 Disable dispersion option supported for HDR images

To calculate colour metrics you may need to remove the fire by disabling dispersion. All fire will turn into scintillation.

To disable dispersion uncheck button **Disp** on the toolbar

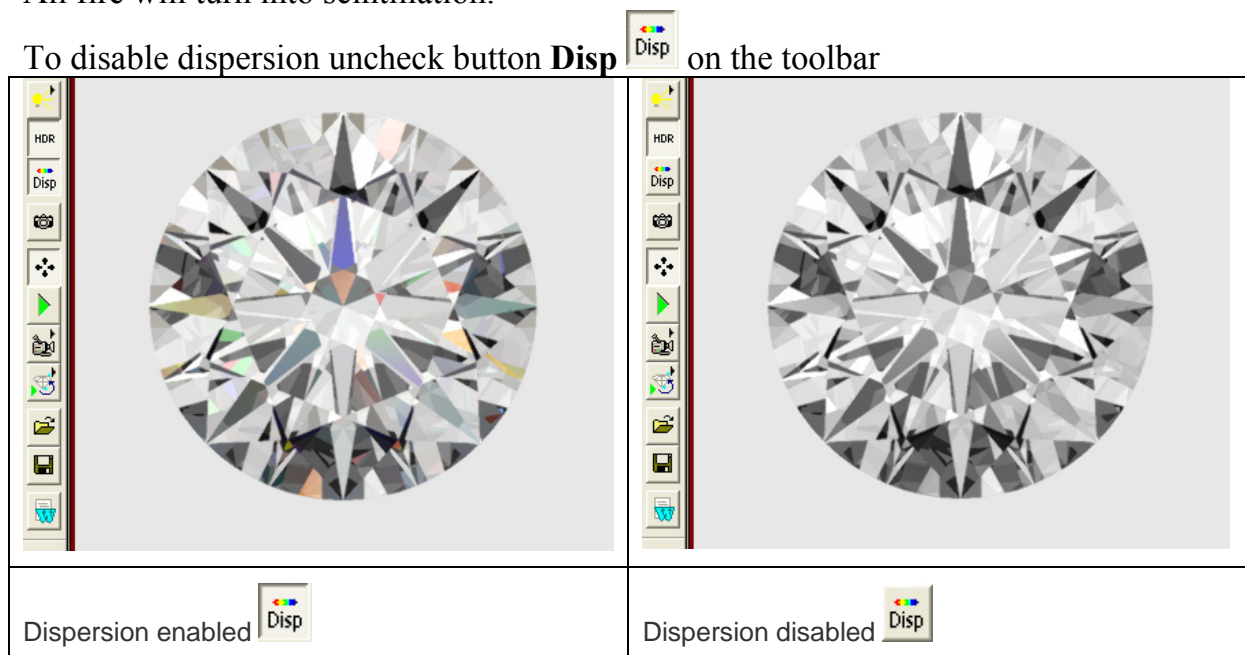

*Note. To use another way to disable dispersion:*

- Press button **Illumination type** 
- Choose **Customize...**

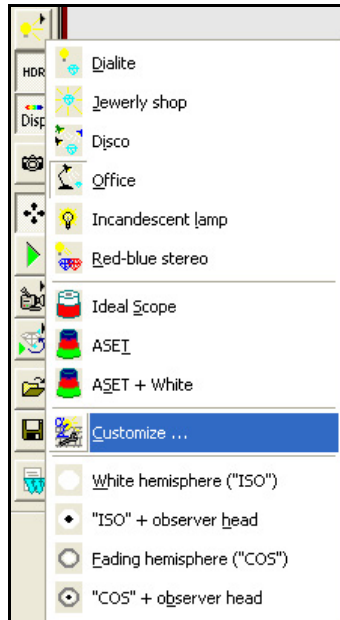

- Select checkbox **Ignore dispersion**

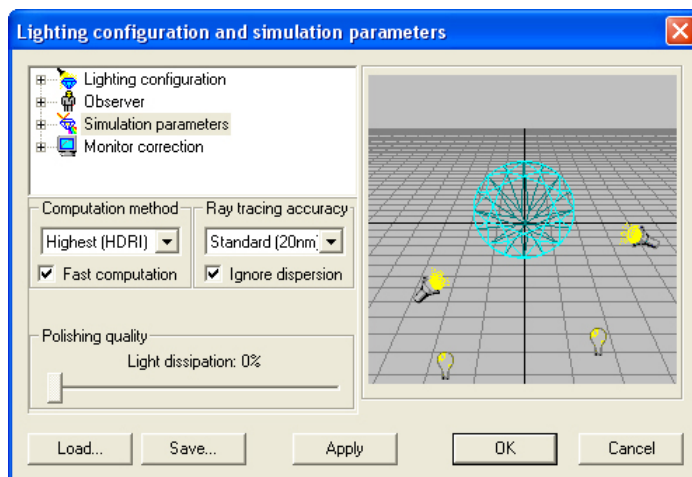

- Press **Ok**

### 3.14 New features in import of Transmission Spectra

New import option for transmission spectrum is available.

To import spectra:

- Select from menu **Gem material / View / Modify properties...**
- Press button **Import Transmission Spectrum...**

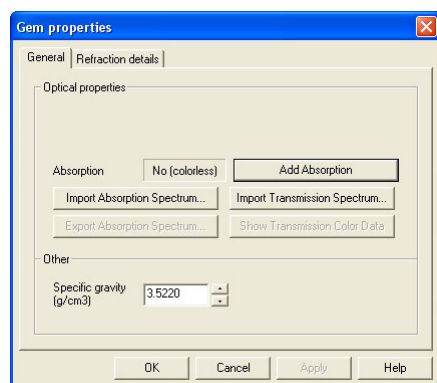

- In addition to the previous method of importing the data of the percentage of transmission for each wavelength, it is now possible to import two data files: one containing the energy spectrum of actual light source and one for the energy spectrum of the tested sample as recorded in that specific light source.

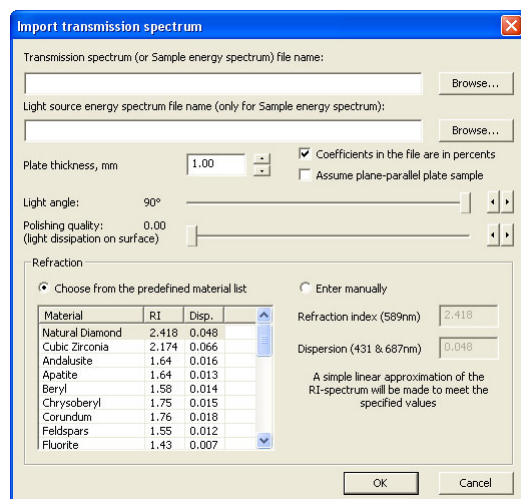

Another new option is calculating absorption spectrum from transmission with assumption of nearly-ideal plane-parallel plate. This option is switched off by default and requires only considered usage.

To analyze the color of the spectrum after importing transmission spectrum:

- Press button **Show Transmission Color Data** in the panel **Gem properties**

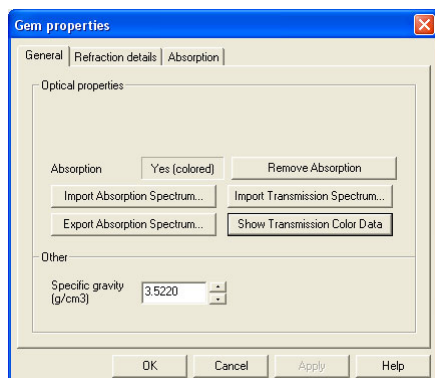

- See color information of imported transmission spectrum

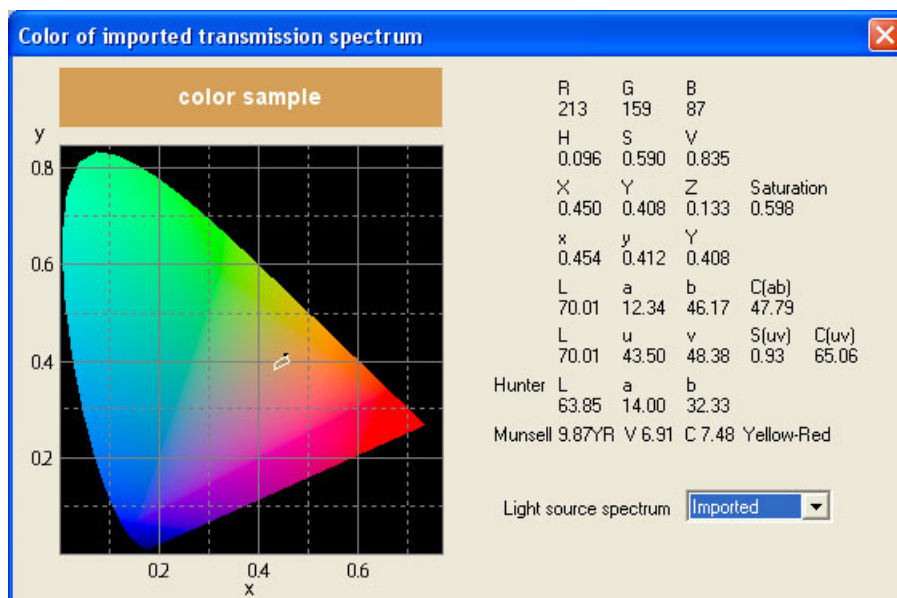



*Note.* If there is a small white polygon in the chromaticity diagram it shows by its corners approximately the coordinates of standard Munsell chips of Value closest to current and of Hues and Chromas closest to current color

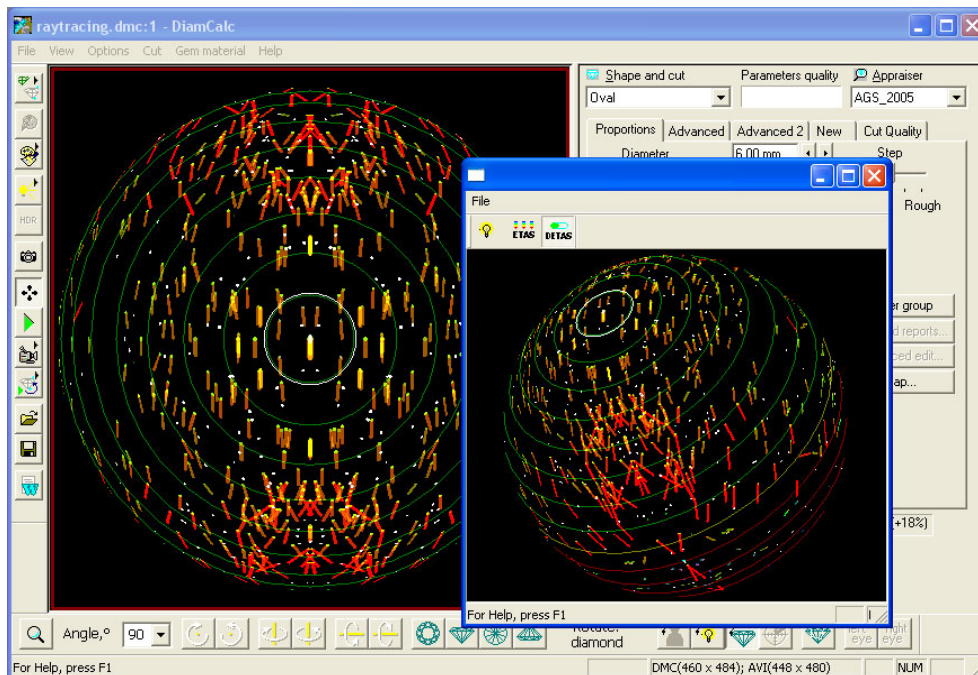

### 3.15 10-degree step latitude grids for the DETAS globe

10-degree step latitude grids are displayed on the DETAS sphere panel along with a marker of space occupied by an observer's head indicated by a white circle.



To open **DETAS** mode press button  and select from list **Dynamic ETAS**  or select from menu **Options / View HDR panorama / ETAS...**



### 3.16 Making panorama, observer and paper image lighter or darker by multiply coefficient

New multiply coefficient allows to make panorama, observer and paper image lighter or darker. To make an image darker set coefficient less than 1. To make an image lighter set coefficient more than 1.

#### Panorama

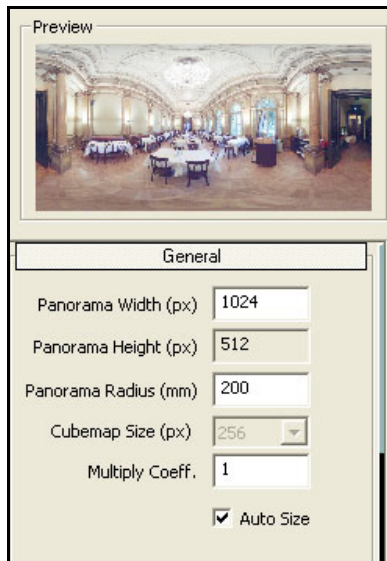

Multiply Coefficient = 1

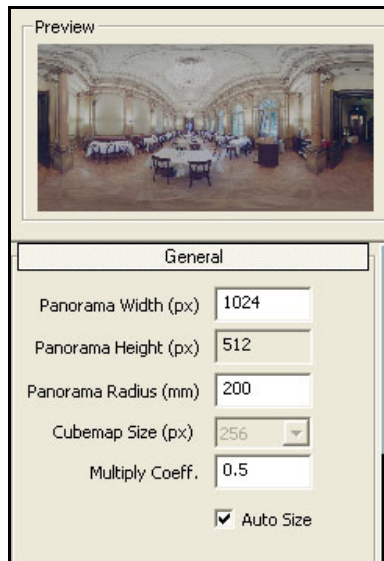

Multiply Coefficient = 0.5

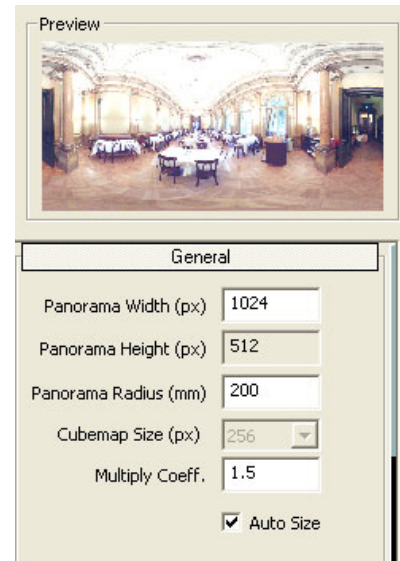

Multiply Coefficient = 1.5

## Paper image

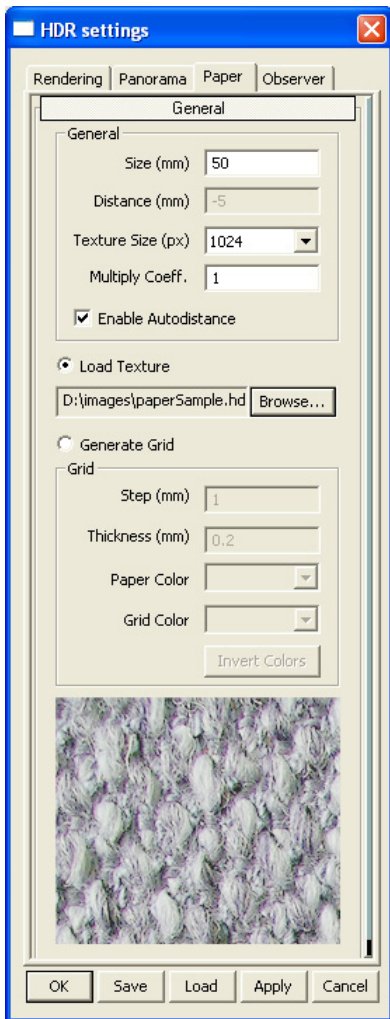

Multiply Coefficient = 1

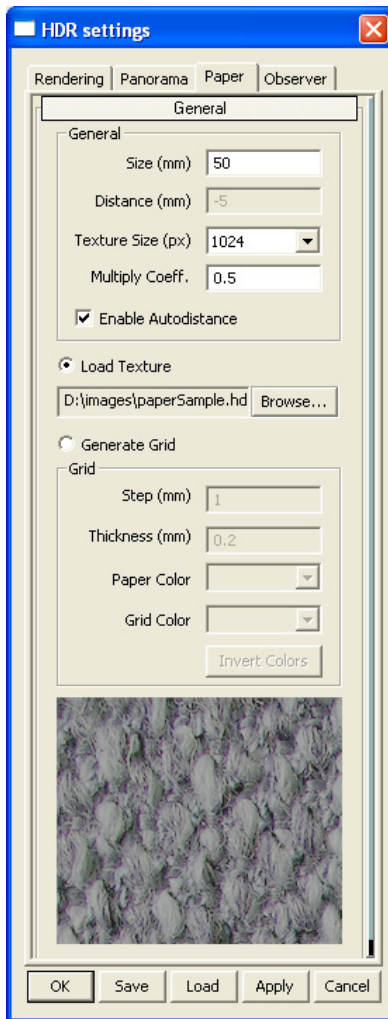

Multiply Coefficient = 0.5

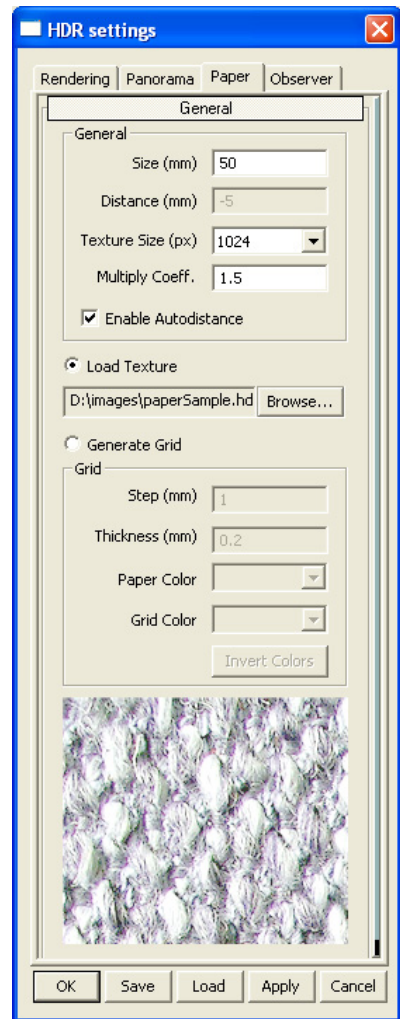

Multiply Coefficient = 1.5

## Observer

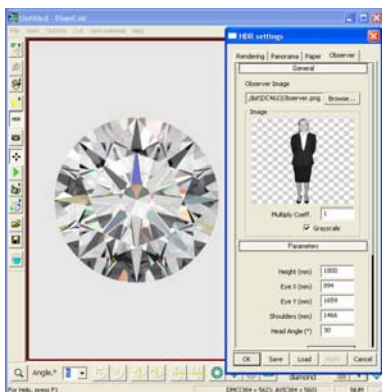

Multiply Coefficient = 1

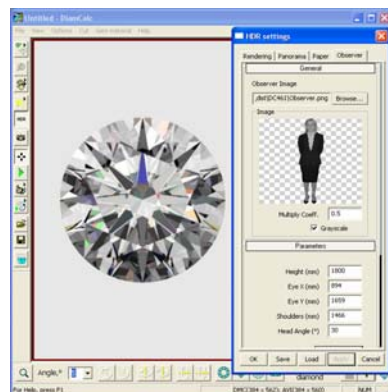

Multiply Coefficient = 0.5

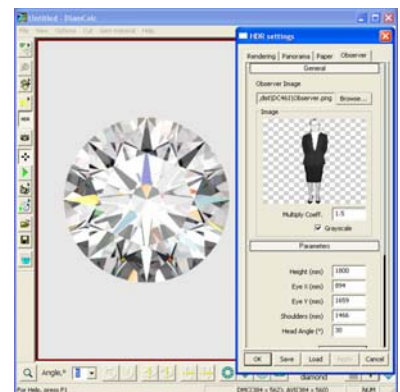

Multiply Coefficient = 1.5



### 3.17 Loading of DMC files with DLL cutting; an improvement

In the previous version DMC file could not be opened if DMC file contains cutting from external DLL and this DLL has not previously been saved in the cuttings folder. In the new version the DMC file opens even if DLL is absent in the cuttings folder. It is possible to work with this loaded cutting without DLL just as if it were any other imported external format (DXF, STL etc)

### 3.18 Batch conversion to STL

An automated conversion of files from DiamCalc (DMC) and GemAdvisor (GEM) to binary STL format is available now.

To convert several files to stl:

- Select from menu **Cut / Batch processing / Convert from DMC / GEM to binary STL...**

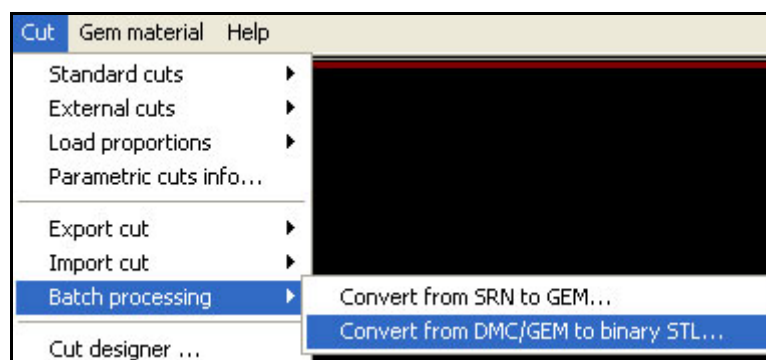

- Select set of files in the dialog window **Open**

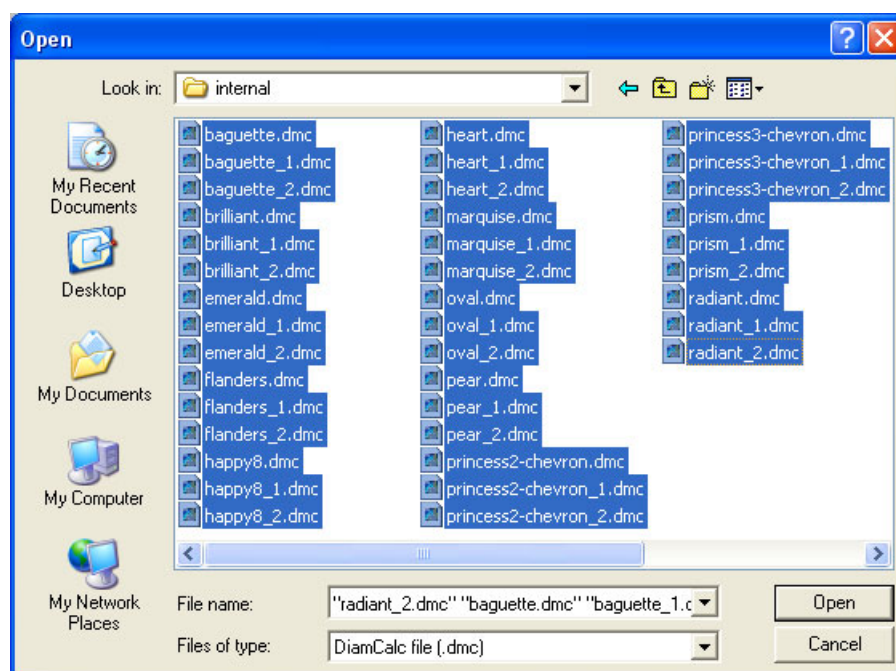

- Press button **Open**

Selected files will be converted into STL files with the same filenames

### 3.19 Creating custom girdle in the Cut Designer

New feature allows creating various shapes of girdle for user choice (See sections **Creating custom girdle shape**). It is possible to create girdle contour from existing cut shape or from any shape created by the third party software (See section **Creating custom girdle shape by third-party software**).

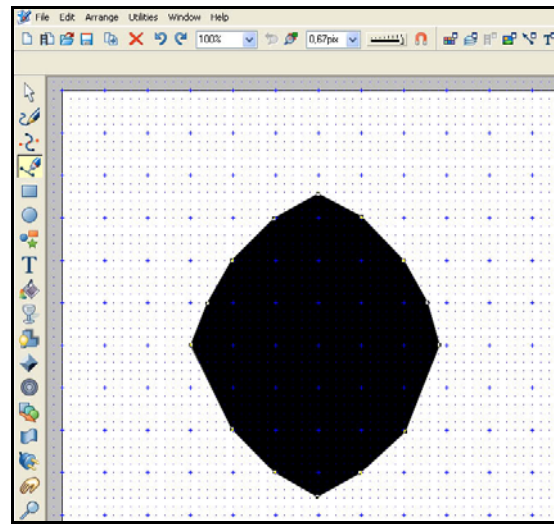
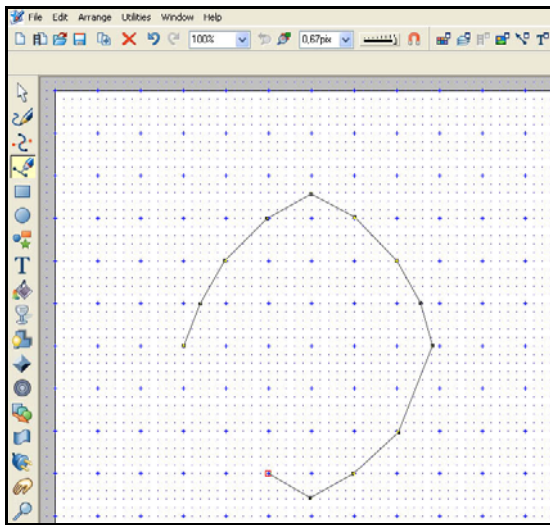

Creating Girdle shape in the Xara Extreme software

### 3.20 Grayscale mode for observer

To make the observer's image grayscale separately from the whole scene check **Grayscale** checkbox in the tab **Observer**. This takes away any colour that may be resulting from the observer's skin tone and their clothing.



### 3.21 High-quality ray tracing modes available in HDR rendering

**Accurate (10nm)** and **High-accuracy (5nm)** ray tracing modes are available for creating HDR images of the diamond.

To select / change new ray tracing mode:

- Press button **Illumination type** 
- Choose **Customize...**

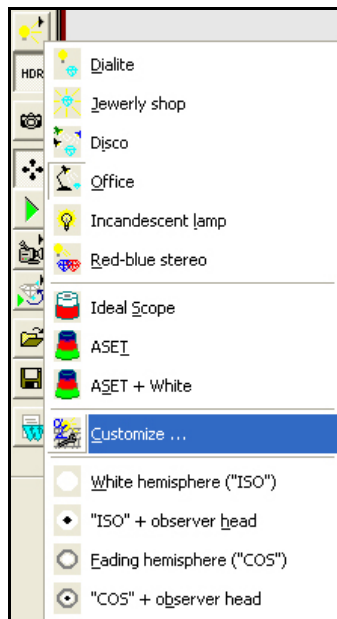

- Select **Ray tracing accuracy** from list

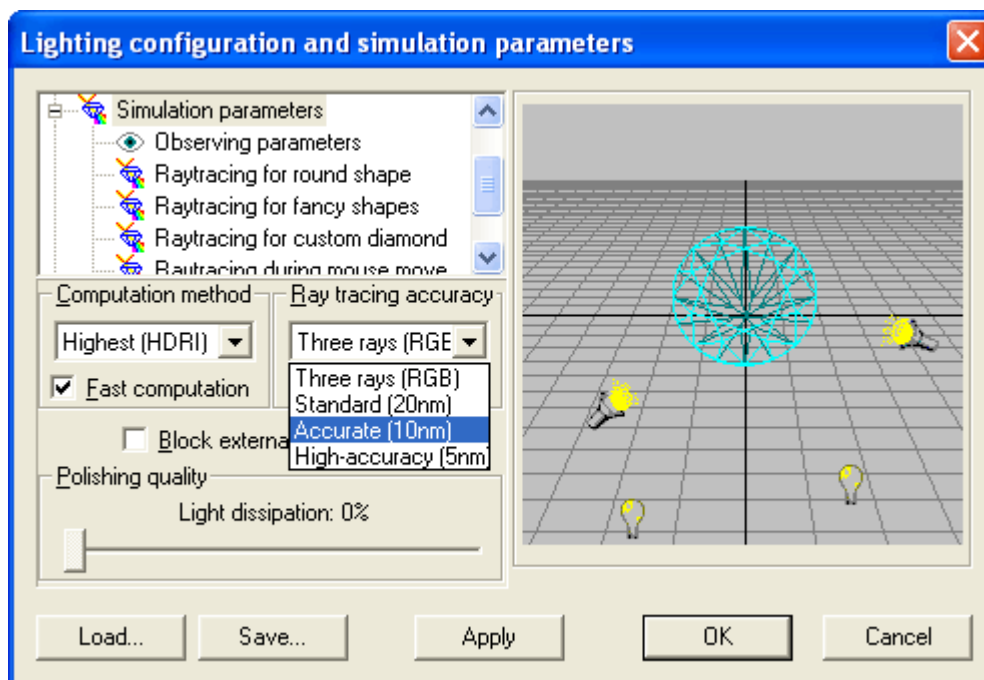

- Press **Apply** or **Ok**



**Table. Ray tracing accuracy modes**

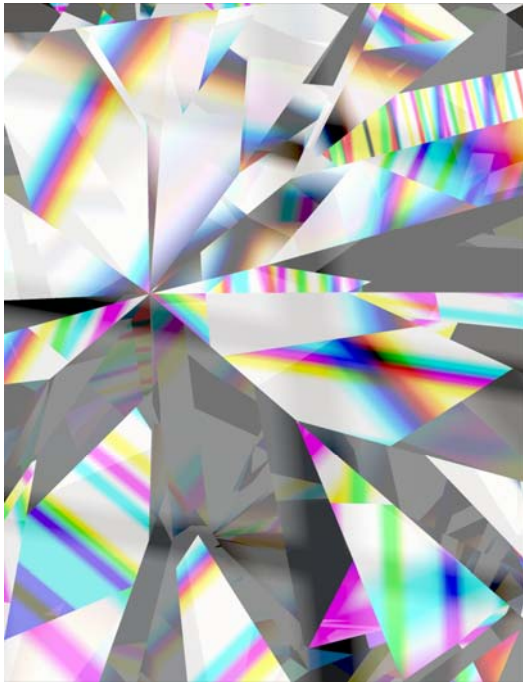

Three rays (RGB)



Standard (20nm)



Accurate (10nm)



High-accuracy (5nm)

### **3.22 JPEG, PNG, BMP, TIFF files formats are supported**

New version supports JPEG, PNG, BMP and TIFF formats for panoramas, observer and paper.





### 3.23 Paper auto distance mode

Paper Autodistance mode is available. In this mode paper is placed at a tangent to the gemstone.

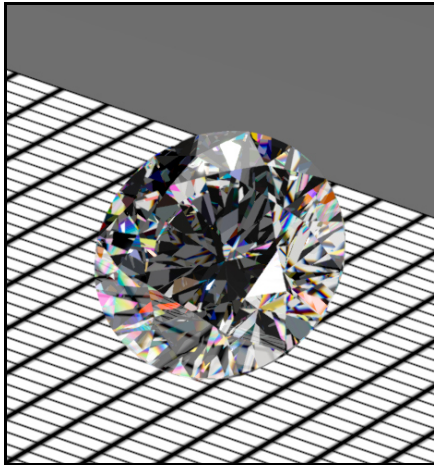

To enable Autodistance select checkbox **Enable Autodistance** in the tab **Paper**

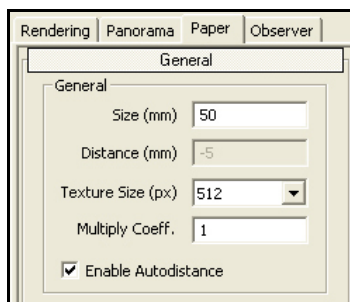

### 3.24 Rendering of the diamond covered by the paper

Rendering of diamond covered by the paper is available. When observer is rotated paper might cover the diamond, and it becomes invisible under the paper.

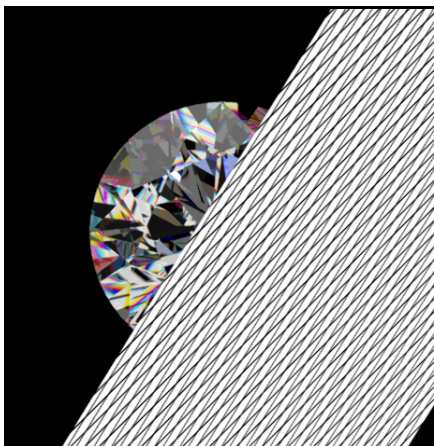

### 3.25 HDR supports standard lights: Office, Disco, Jewelry shop, ASET and others

To enable standard light witch supported in HDR Photorealistic mode:

- Select **HDR Photorealistic (hdr image)**

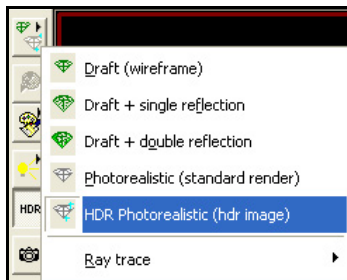

- Be sure the checkbox **Enable Standard Lights** in the tab **Panorama** / section **Lights** is selected



- Choose desired standard lights: Office, Disco, Jewelry shop, ASET etc

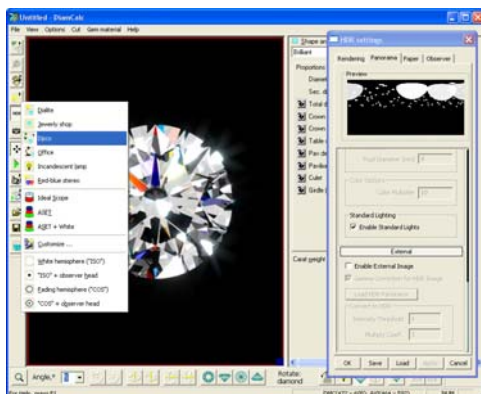

### 3.26 Different default files paths for different dialogs set by the user

Now when you save or open the a file, the path of it is remembered for every dialog, so next time, when you need to save or load the file – you'll be in the same folder you worked before for every dialog.

### 3.27 Saving scale, stone environments, rendering and movie settings in DMC file

DiamCalc allows to save most of scene and rendering settings in DMC file:

- Scale
- Lighting configuration
- HDR settings
- Movie settings

So, when you open the file again the stone will be the same as when it was closed

### 3.28 Custom Color Spaces for HDR Images is available

Now HDR mode supports different colour spaces:

- DC Old
- NTSC
- CIE
- Adobe
- BestRGB
- BetaRGB
- ProPhoto

To change color space:

- Select from menu Options / Lighting / Customize.../ Monitor correction / Gamma correction
- Select color space in the list **RGB Primaries**

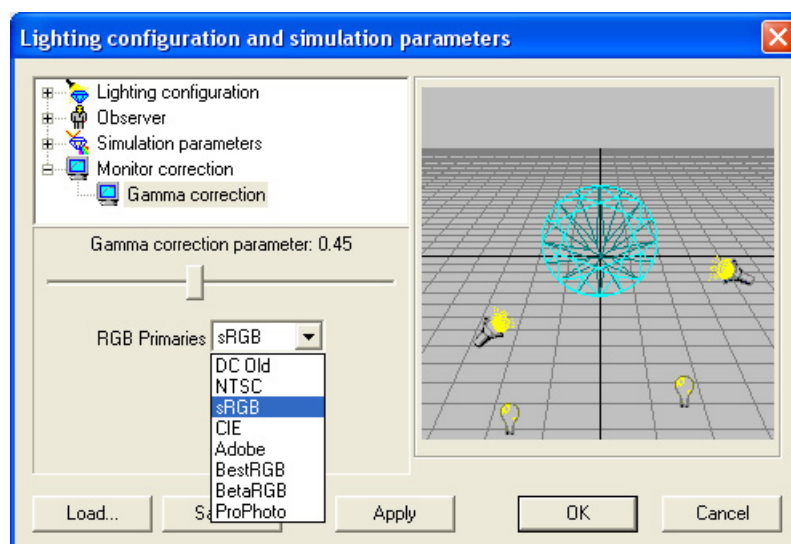

There are different ways to project a Human perception of a colour space to a Monitor color space. An analogy is various projections of the terrestrial globe to 2d map where for example the islands of Canada appear much larger than they actually are.



### 3.29 New tone-mapping

New enhanced algorithm of representation of very bright sparks in diamond picture is introduced. It makes simulated pictures more close to photographs.

### 3.30 Memory requirements for HDR panoramas are reduced

Now working with HDR panorama files requires less of memory. It allows to load and work with larger panorama files.

### 3.31 The real radius of HDR panorama

New parameter **Panorama radius** allows you to set the real radius of HDR panorama – the radius of sphere with diamond in center.



By default **Panorama radius** is equal **5000 mm**. It is the common size of a room.



### 3.32 Gamma correction for HDR images

Some of HDR panorama images need to be gamma corrected. To make gamma correction load panorama and select checkbox **Gamma Correction for HDR Image** in the tab **Panorama** section **External**.

Look at the difference of panorama image before and after gamma correction:

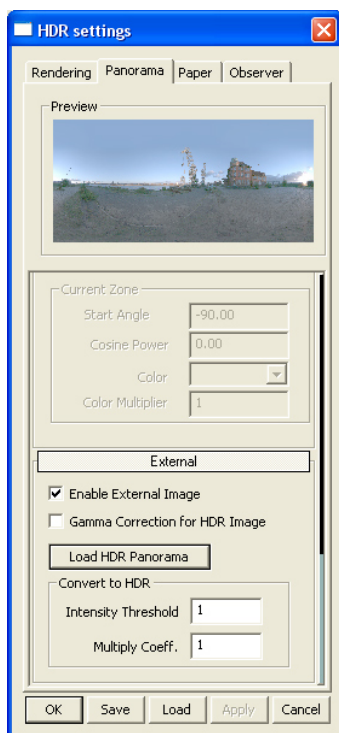

Before gamma correction

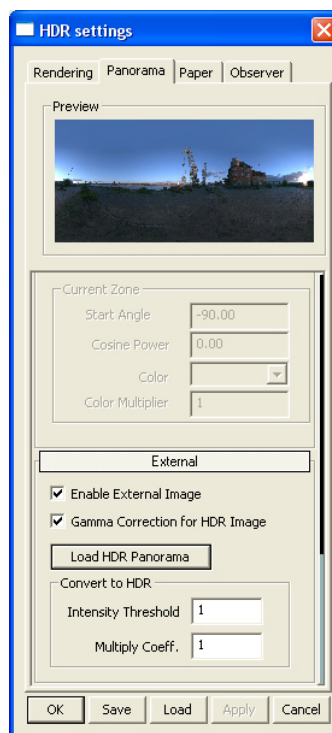

After gamma correction

### 3.33 Scenarios

There is a set of scenarios for DiamCalc 3.2. It demonstrates different possibilities and effects of new version of the program:

- Bloom and stars
- Inclusions
- Papers
- Papers with dot
- Flat plate
- Standard lightings

To use the scenarios:

- Download the archive [scenarios.zip](#) included scenarios as a set of DMC files
- Unpak the archive
- Open DMC files in the program DiamCalc and explore it

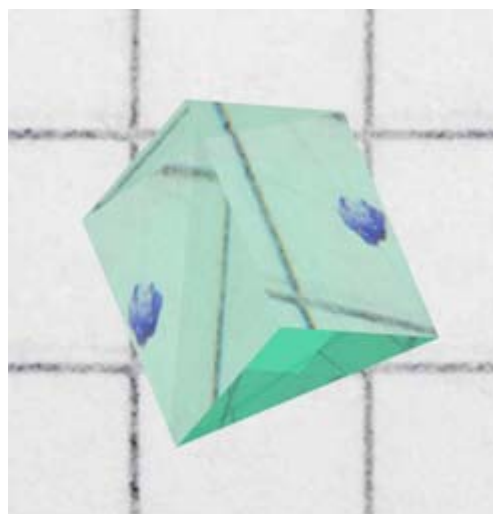

## 4 Visual presentation of a diamond

DiamCalc supports different types of visual presentation of diamonds under different lighting conditions. It allows you to produce realistic views of a stone.

DiamCalc supports several different types of diamond images. A diamond can be seen from different angles or even from two different positions simultaneously. Each diamond view can be further customized to produce even better visual impression.

### 4.1 Model types (wireframe and rendering)

3D model of a diamond is displayed in the left part of DiamCalc main window.

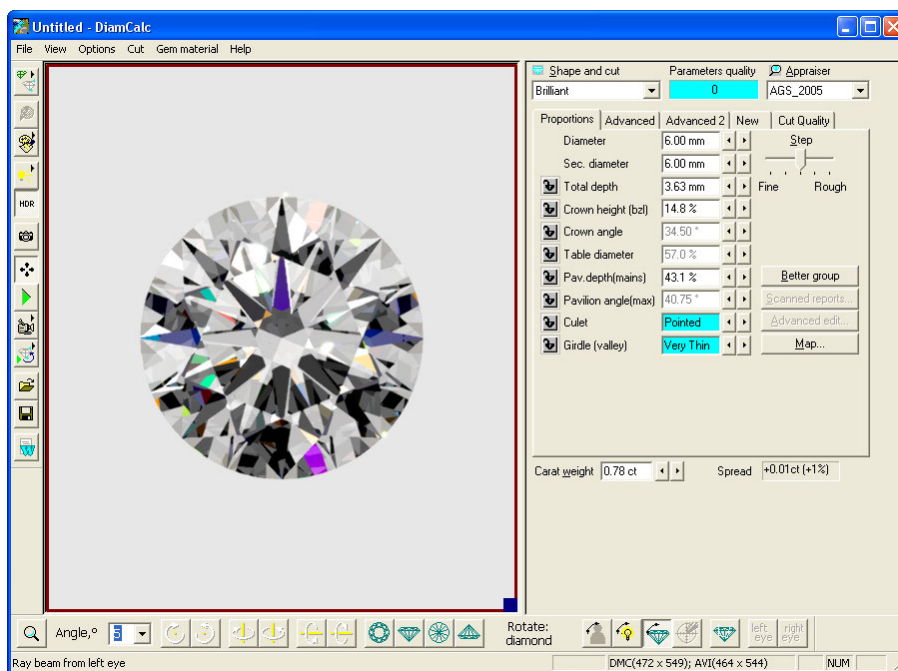

Depending on purpose various representation types of model image are used:

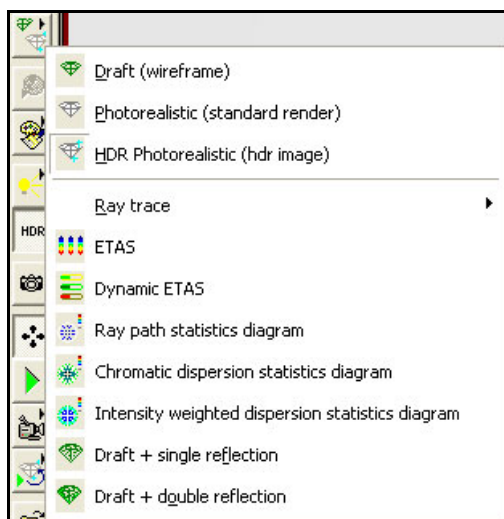

- Draft (wireframe)
- Photorealistic (standard render)
- HDR Photorealistic (hdr image)
- Ray trace
- ETAS
- Dynamic ETAS
- Ray path statistic diagram
- Chromatic dispersion statistics diagram
- Intensity weighted dispersion statistics diagram
- Draft + single reflection
- Draft + double reflection

To change model type press button  and select rendering type from list:



### Draft mode (wireframe)

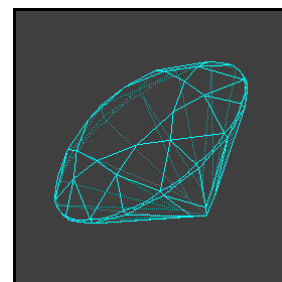

Draft mode shows the diamond as a three-dimensional framework. Visible and invisible edges are seen as solid and dashed lines, respectively. Facets are now drawn, color and illumination is not taken into account. This option is useful for the visual determination of proportions girdle edges etc. This mode is the default one.

To set Draft mode press button  and select **Draft (wireframe)** 



### Photorealistic (standard render)

Photorealistic mode simulates the real diamond under certain lighting conditions and considering the particular properties of a diamond specimen. Sometimes, photorealistic image is very similar to the photograph of the real diamond.

To set Photorealistic mode press button  and select **Photorealistic (standard render)** 

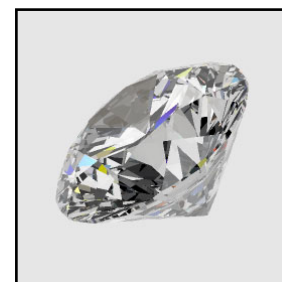

### HDR Photorealistic (hdr image)

HDR Photorealistic mode generates highly photorealistic images. It takes into account optical properties of gemstones and compound features of environment. High Dynamic Range lighting can come from a variety of panoramas such as a ball room, forest or hillside so this mode allows to see how the diamond will look in each of these environments.

To set **HDR Photorealistic** mode press button  and select

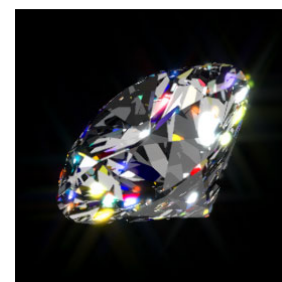





## ETAS

**ETAS** (Effective Total Angular Size of a diamond) mode is an estimate of the probability for a small light source to be seen through the diamond.

Fire is an estimate of probability for colored dispersed light to be seen due to chromatic dispersion of the light source caused by the crystal.

Light sources are assumed to be located at the sphere of 2000 mm radius around the diamond's center which was chosen as a common distance from the diamond to light sources.

To open **ETAS** mode press button  and select **ETAS** 

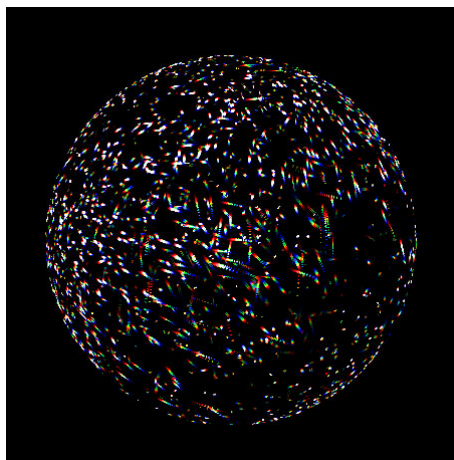

## DETAS

**DETAS** (Dynamic ETAS) mode is ETAS that considers a diamond in motion of 2 degrees of tilt in the north south orientation as if the stone was moved away from the observer. While tilting, a diamond *scans* the space around it, thus increasing the probability to see a light source.

As the diamond is tilted it scans the space around it, thus increasing the probability of seeing a light source.

The stripes in the DETAS are the trails of ETAS spots that crawl across the sphere as the diamond is tilted away by 2 degrees from its initial face up position. The color represents the crawling speed: the faster spot crawls the more reddish is a stripe



Blue color means that the spot doesn't move upon diamond tilting

Green color means that the spot crawls as fast as one from a tilting mirror

Yellow – is a little faster

Red color denotes the fastest spots

Spheris 10-degree step latitude grids are displayed on the DETAS panel along with the marker of space occupied by observer's head indicated by white circle.

To open **DETAS** mode press button  and select **DETAS** 

*Note. ETAS, Fire and DETAS are all compared to a 6mm diameter Tolkowsky diamond.*

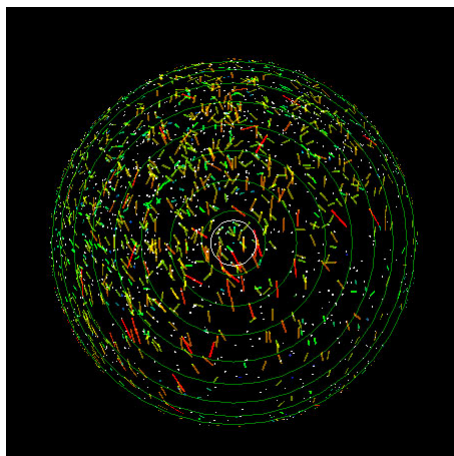



## Statistic diagram

The diagrams show the statistic properties of the light ray's trip across the gemstone crystal in the course of rendering. Maximum angle of chromatic dispersion, this angle weighted with ray energy and average ray path inside the crystal are represented with different colors for each spot of the diamond picture.

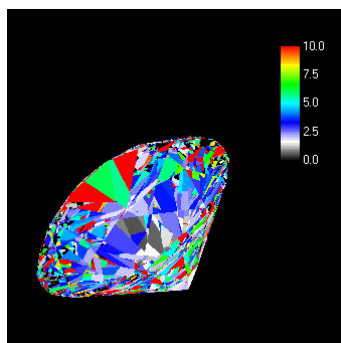

Chromatic dispersion statistics diagram: maximum angle of chromatic dispersion is sampled throughout the diamond picture.

Color band at the right shows the values scale (degrees)

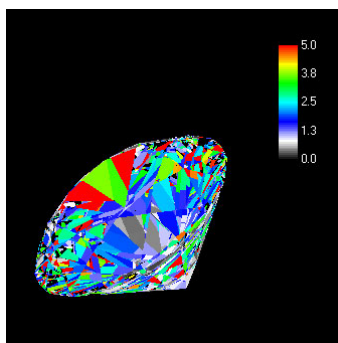

Intensity weighted dispersion statistics diagram: maximum value of ray brightness time's chromatic dispersion angle is sampled throughout the diamond picture.

Color band at the right shows the values scale (degrees times fraction of unity)

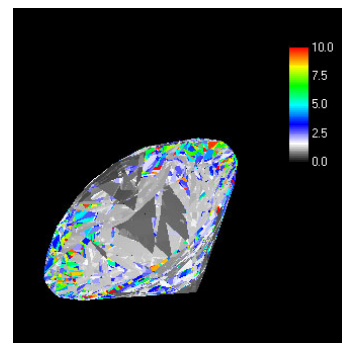



Ray path statistics diagram: average path the light ray traveled inside the diamond is sampled throughout the diamond picture.

Color band at the right shows the values scale (units of diamond's diameter)

To open **Statistic diagrams** press button  and select **Chromatic dispersion statistic diagram** , **Intensity weighted dispersion statistics diagrams**  or **Ray path statistic diagram** .

## Draft modes with reflection

**Draft modes with reflection** are similar to the **draft (wireframe)** mode, but they also show which edges and facets would be seen through the diamond surface with regard to edge refraction and reflection. There are two modes in this category: **Draft + single reflection** and **Draft + double reflection**. The difference between them is modes take into account one or two reflections of the light, respectively.

To set one of draft modes with reflection and refraction press button  and select **Draft + single reflection**  or **Draft + double reflection** .

*Note. All models except Draft, especially HDR photorealistic mode, require significant calculating power, so images can be slow to redraw on less powerful computer systems. At least Pentium II, Celeron or comparable processor is recommended. Intel Core 2 class is advisable for fast calculation of*

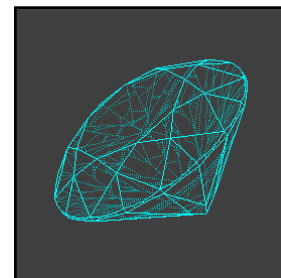



*photorealistic images. All types of models can be seen on a slower system as well, but you may experience a significant delay when the image is redrawn. In these cases, it is recommended to set Draft model type, change all parameters you want to modify, rotate the diamond to the position that you want to inspect, and set a view mode other than Draft only then. With this method, only one slow redrawing is required and you avoid delays after each change of diamond parameters and position.*

## 4.2 HDR rendering effects

See section **Photorealistic HDR rendering** for options customization

### Bloom effect

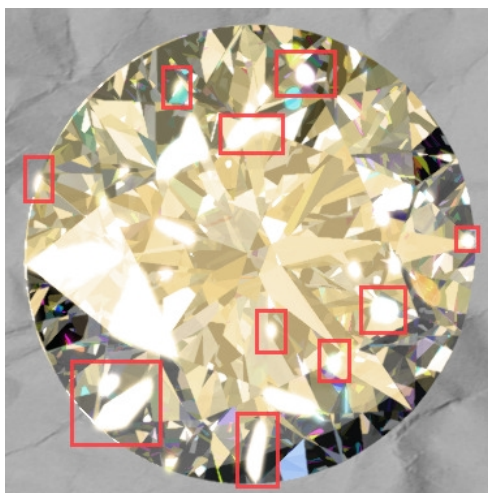

The bloom or flare effect produces fringes of light around very bright objects in an image, as stressed by the red squares in the actual rendering screenshot below:

The physical basis of bloom is that lenses (including those in our eyes) can never focus perfectly in the real world. Under normal circumstances, these focus imperfections are not noticeable, but an intensely bright light source will cause the imperfections to become visible. As a result, the image of the bright light appears to spread (bleeds) beyond its actual borders.

Depending on the background colour or shade, the bloom can appear to extend outside the edges of the diamond.

### Stars effect

Stars effect is a feature which appears in real life when a bright object is observed in darkness, and there is an occluder object in front of it.

In case of human eye, eyelashes could be such occluder, producing stars effect. In case of camera, polishing or scratching on the objective stand for occluders.

Besides, aperture of lens / eye affects stars effect greatly. In case of camera, lens aperture is a regular polygon, so it could be completely defined by radius of circum circle and number of aperture blades.





## Lighting panorama with high dynamic range (HDR)



A lighting environment can be defined by a high dynamic range panorama (also referred to as HDR panorama). Luminance or radiance observed in the real world can usually be stored in special high dynamic range images that correspond to actual physical values. This additional information makes high dynamic range images that are different to traditional digital images that may appear on a monitor or on a paper print. For example in the photo image above the bright parts of the sky radiate much more light than is seen in a regular photograph, and such intense light sources can create a bloom or flare in a gemstone.

## Lighting with generated panorama (zones and light sources)

Panoramas with different light sources can be generated by specifying the size and quantity of light sources.

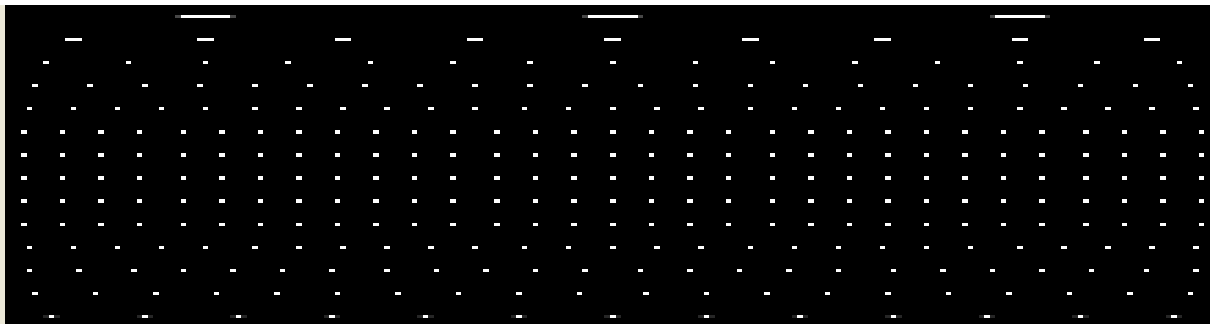

Panoramas with colored zones (up to 8 zones) can also be generated.

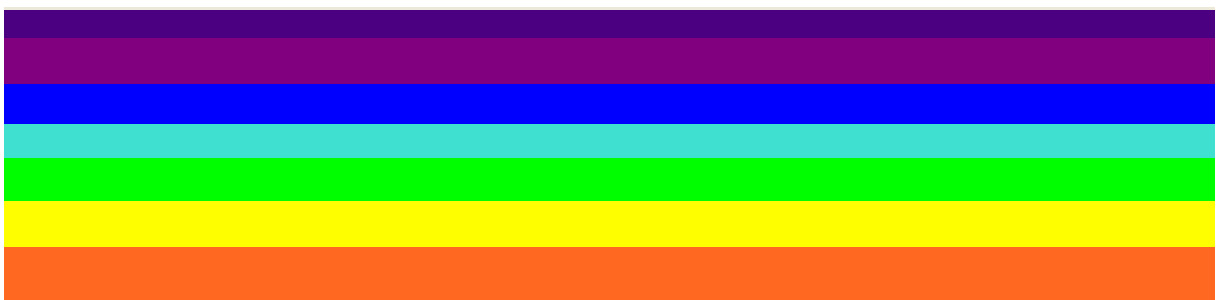



A panorama for the **Office** lighting environment can also be generated.

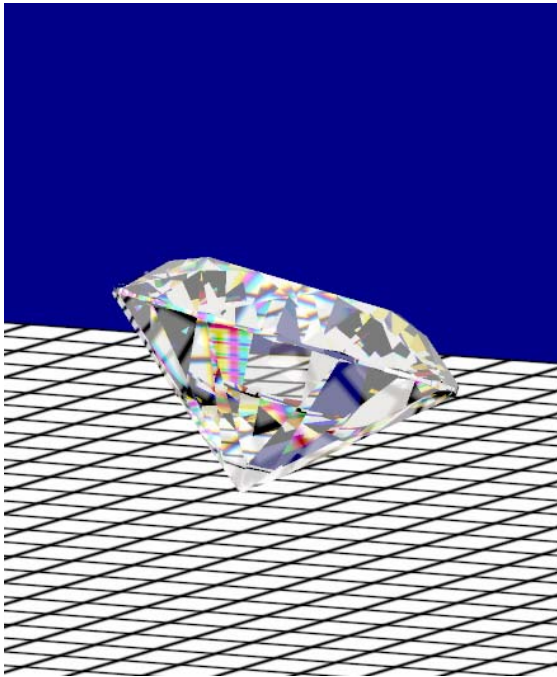
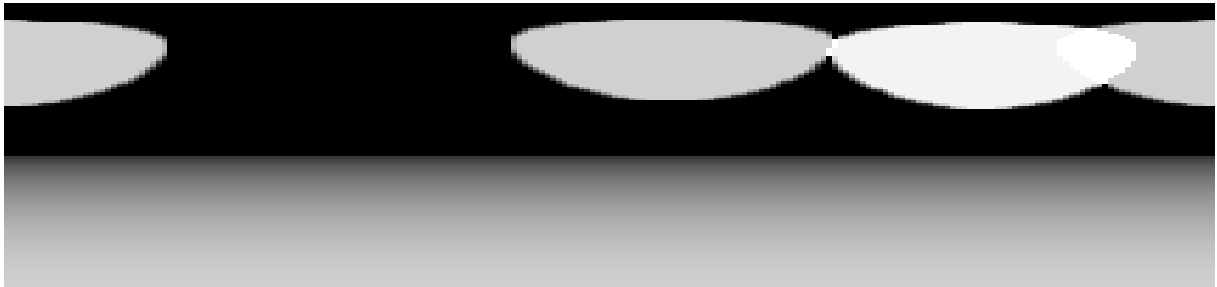

### **Paper sheet environment**

A paper sheet can be rendered either using an external texture or one that is generated in a grid-style. In the latter case, you can customize grid settings, paper color, size and other options.

### **Observer model**

DiamCalc supports a 2D observer model. The observer model consists of two parts: the observer head and the observer body. This observer model design allows simulation of a head inclined above a gem being observed. You can set up the observer height, eye position, shoulder position, head incline angle and mask parameters.

### 4.3 Setting diamond position

DiamCalc allows easy repositioning the diamond by rotating with the mouse and to view diamond from a different angle.

To rotate diamond:

- Click the left mouse button anywhere on the model

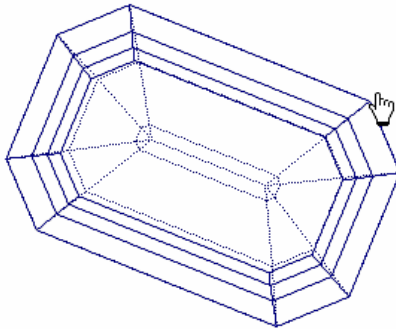

- Hold on the mouse button pressed
- Move the mouse in the direction where you want to rotate it

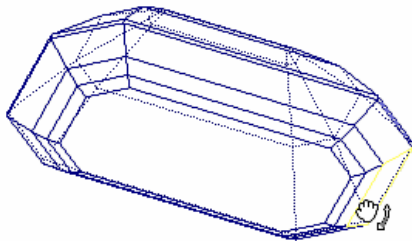

- Release mouse button after diamond is moved to the desired position

There is **Movement** panel in the bottom of DiamCalc window.



The Movement panel allows specifying an angle the diamond should be rotated and rotating the diamond precious by one of six buttons (one for each direction).

Use mouse wheel to scale the diamond.

#### 4.4 Setting one or two simultaneous views of a diamond

DiamCalc can show two simultaneous views of the same diamond taken from different angles.

To split diamond view:

- Select from menu **View / Split diamond view**

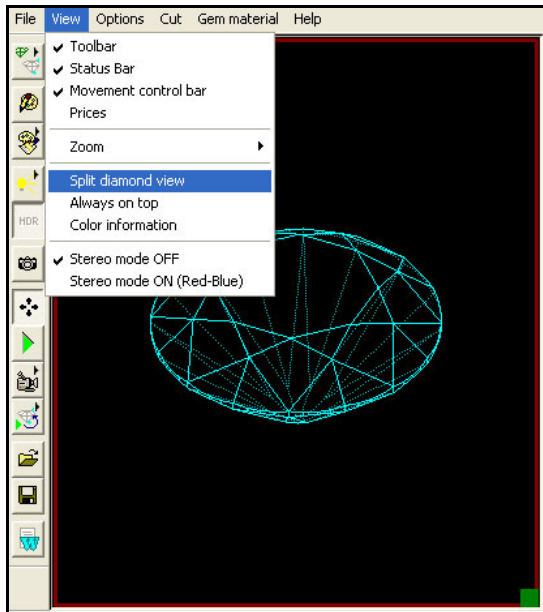

- A horizontal bar appears
- Move it to desired place
- Release mouse
- Diamond scene is split into two panes

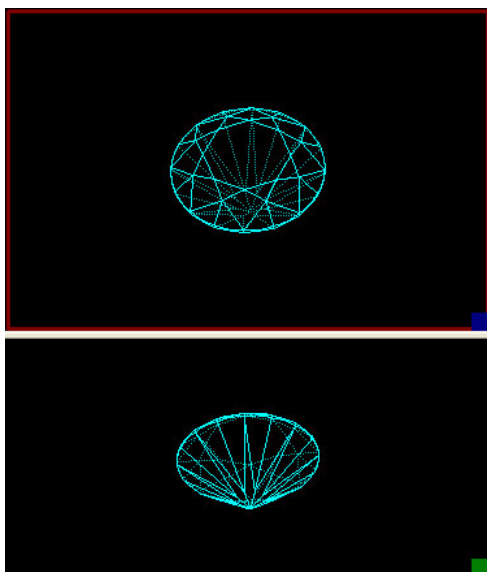





To change type of lighting press button  and selects it from list:



To adjust lighting properties use panel **Lighting configuration...** It allows to configure number of sources, location, size, brightness and other characteristics of each light source.

To open panel **Lighting configuration...** press button  and select **Customize...**

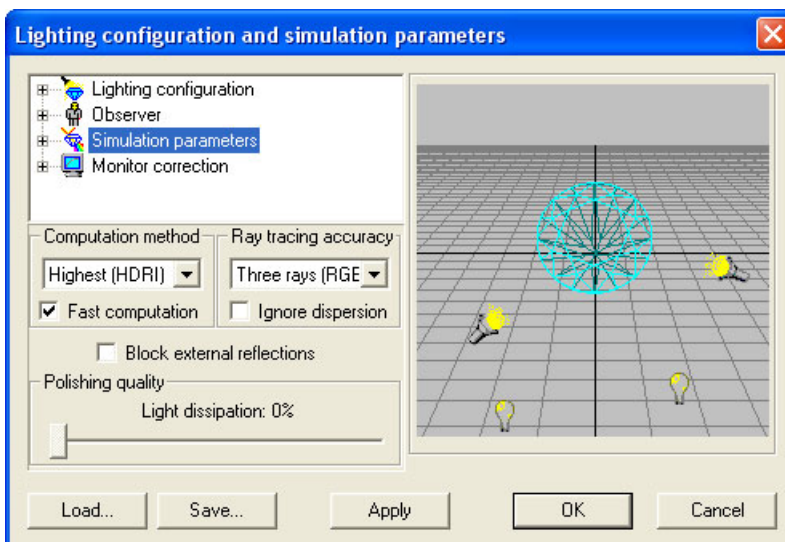

## 4.6 Export movies for iPod / iPhone using DC QuickTime exporter

DiamCalc allows to export *QuickTime* (MOV) movies for iPod / iPhone.

To export QuickTime movie:

- Press button **Movie menu** 
- Choose **Record**:

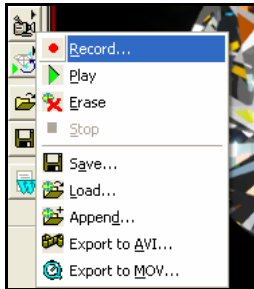

- Set Movie recording options

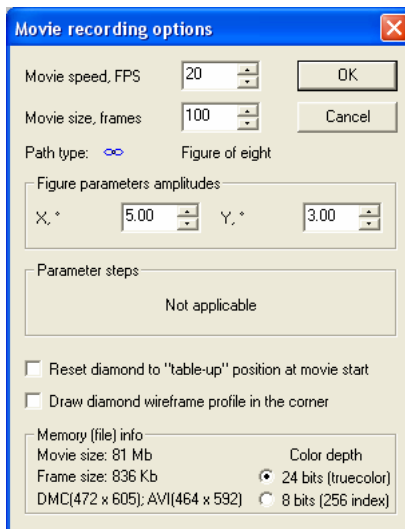

- Press **Ok**
- The recording will proceed. Press **Stop** when movie is ready

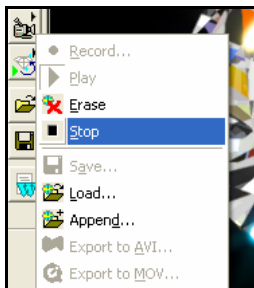

- Choose **Export to MOV....**:

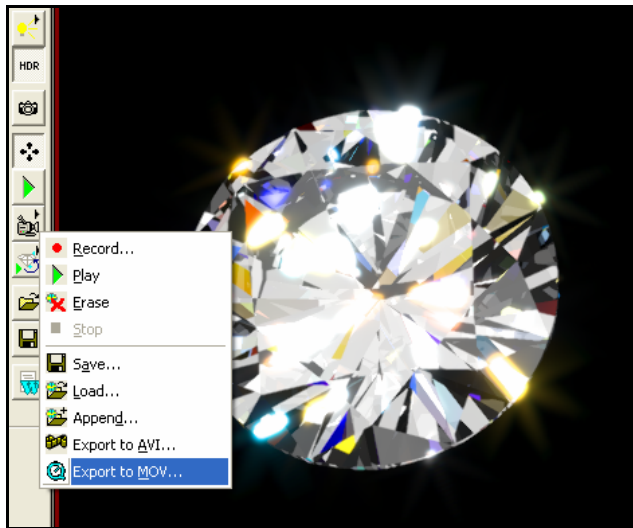

- Import \*.mov file into **iTunes**
- Convert it for your iPod / iPhone in **iTunes**

## 5 Photorealistic HDR rendering options

### 5.1 Getting started with photorealistic rendering options

To configure and set the rendering mode options select from menu **Options / HDR Settings**:

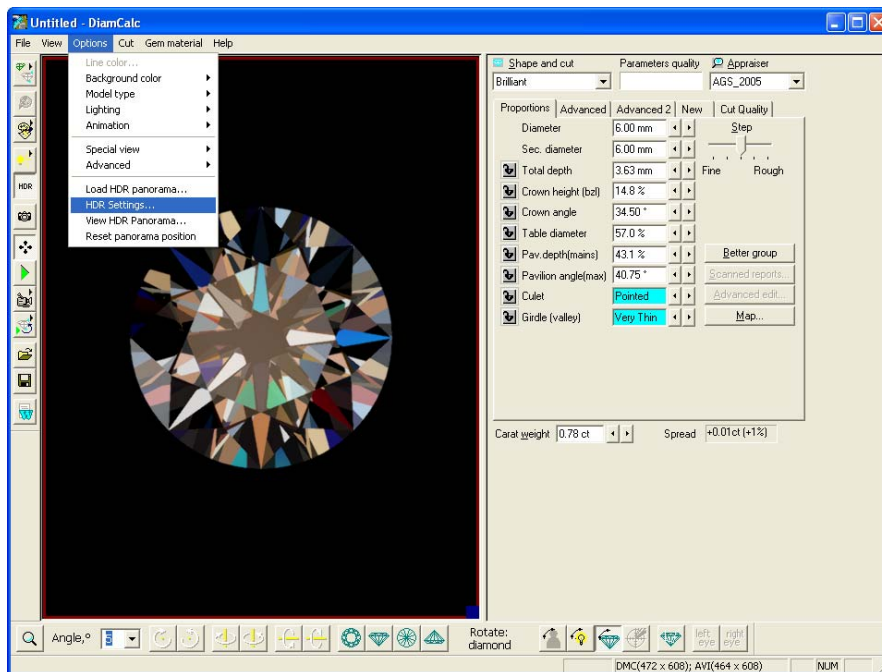

Once **Options/ HDR Settings** is selected the new dialog box **HDR settings** appears:

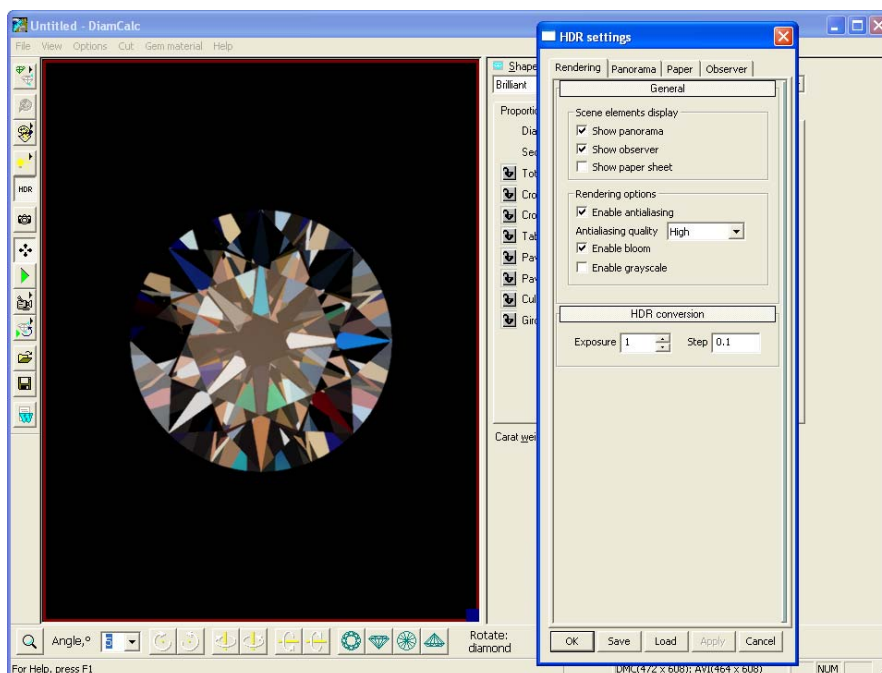

The HDR Settings dialog consists of **Tabs** and **Groups**:

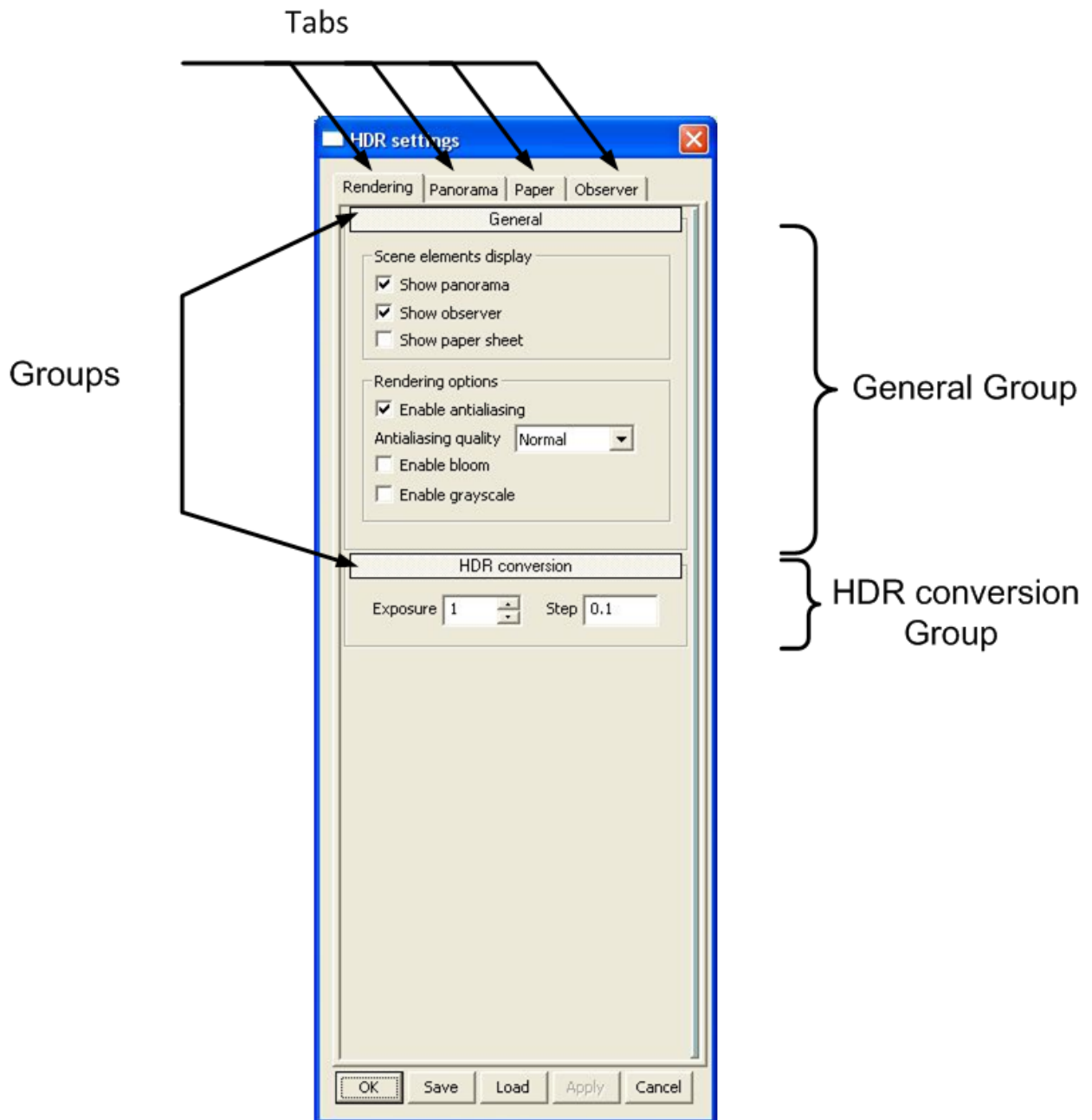

There are four tabs in the HDR Settings dialog:

- Rendering
- Panorama
- Paper
- Observer

Every tab has its own groups. For example, the groups for the tab **Rendering** are shown in the screen shot above.

Click on the group title to hide / show a group. That is, clicking a title of the group being shown makes the group area collapse; clicking a hidden group title makes the group area appear again, as shown below:

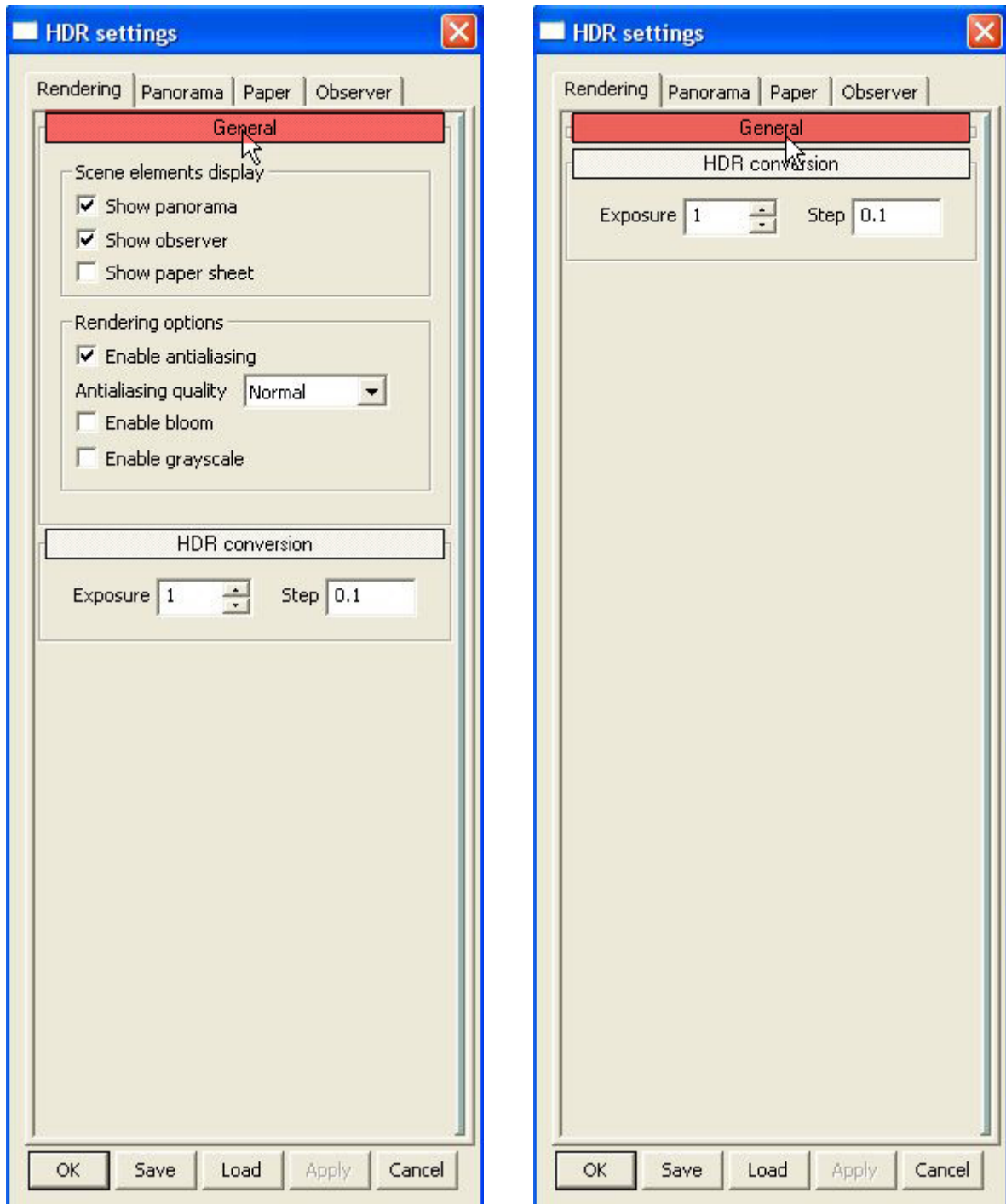



## 5.2 The Rendering tab

The **Rendering** tab options allow to show *scene elements* and disable or enable several *rendering effects*.

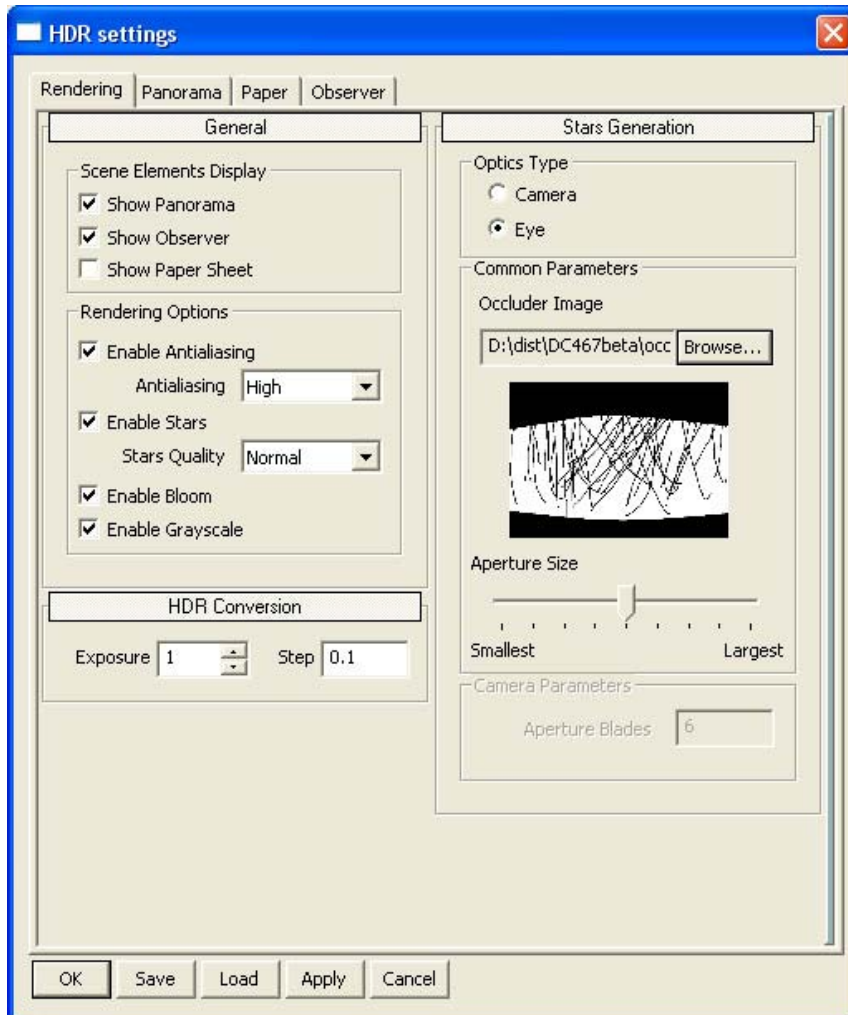

### General options

To show scene elements select it in the section **Scene Elements Display**:

- Show panorama
- Show observer
- Show Paper

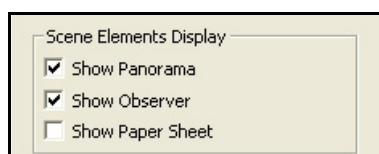

To enable rendering effect just checks the appropriate field in the section **Rendering Options**:

- Enable Anti-aliasing
- Enable Bloom
- Enable Stars
- Enable Grayscale

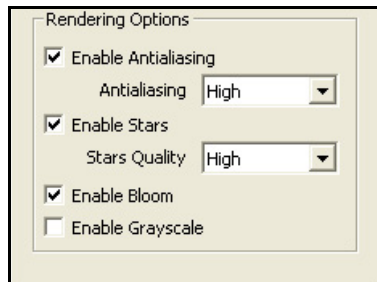

## Stars Generation

To customize star's effect modify options in the group **Stars Generation**:

- Optics type
- Occluder image
- Aperture Size
- Aperture Blades

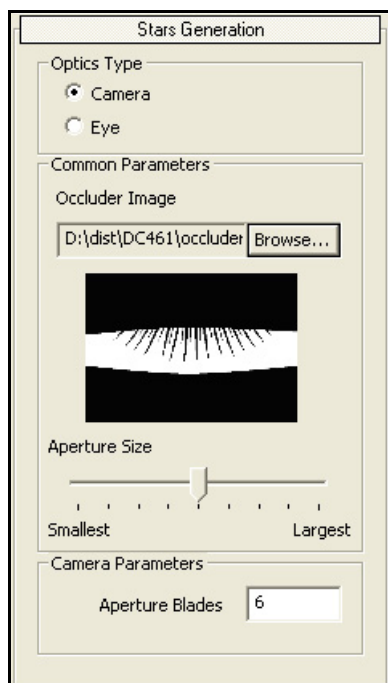



Different occluder images can be chosen from the program kit:

Occluder example

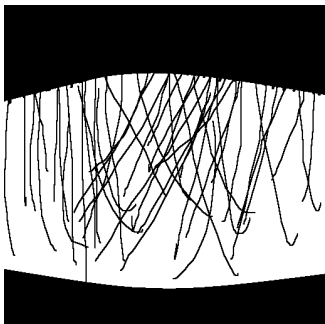
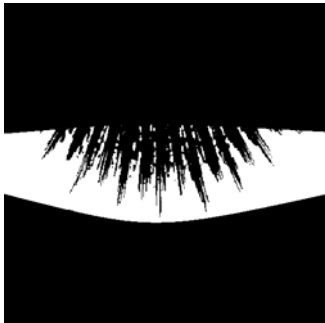
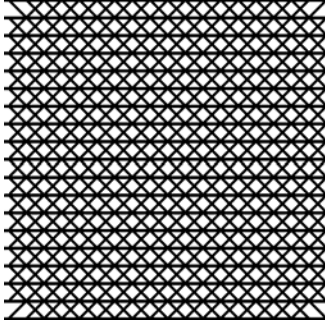

Brilliant internal cut

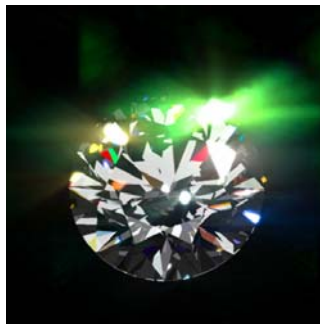
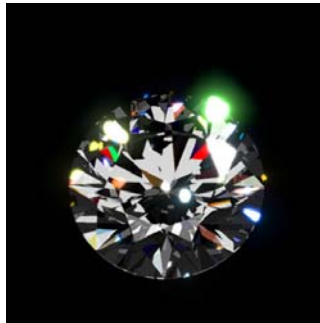

Brilliant external cut

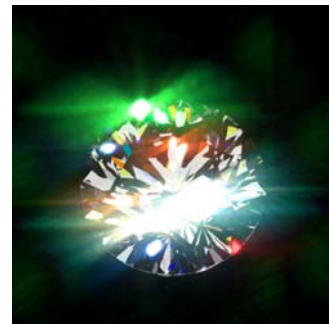
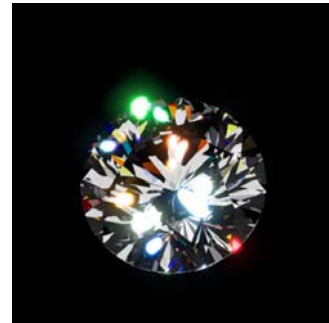

Different aperture blades:

4 aperture blades

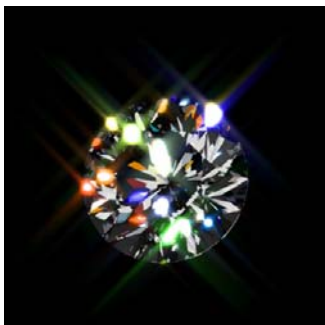

6 aperture blades



8 aperture blades



### 5.3 The Panorama tab

The **Panorama** tab consists of a **preview** window which is always shown at the top and several groups:

- General
- External
- Hemisphere
- Lights

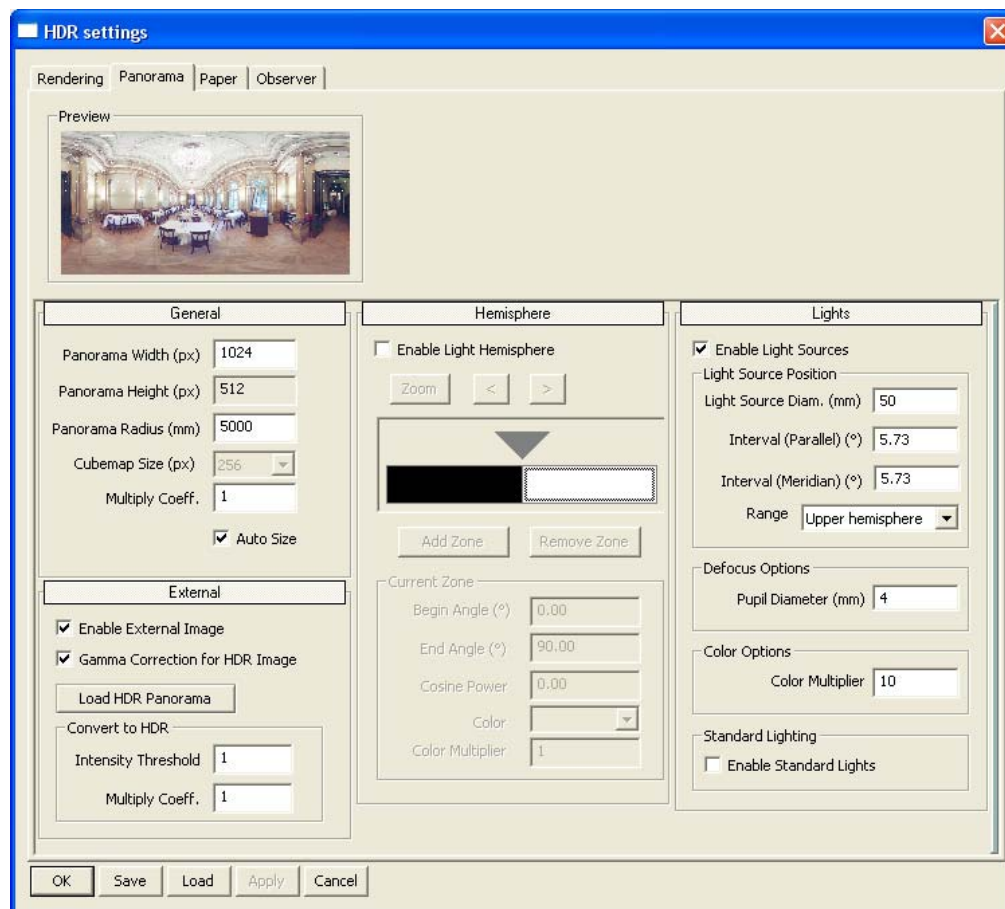

More detailed explanations of the preview window and the Panorama tab groups follow.



## The Preview window

The Preview window allows you to see the current panorama, either a loaded one or a generated one, or both overlain together.



## The General group

The General group allows to set the panorama size.

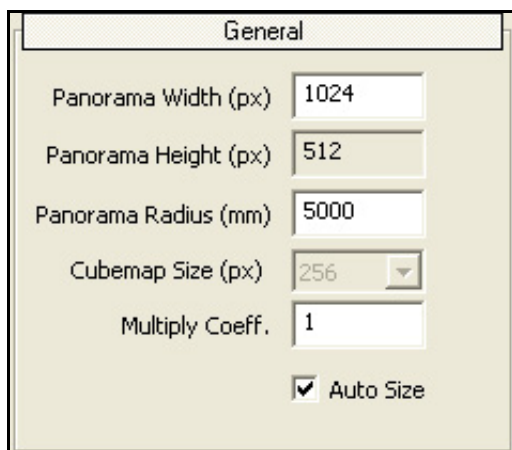

The parameter **Panorama radius** allows to set the real radius of HDR panorama – the radius of sphere with diamond in center.

By default **Panorama radius** is equal **5000 mm**. It is common size of a room.

***Note.** **Auto Size** should be switched on. In some cases, if you have not power video card, you can switch off **Auto Size** to set small Cubemap size of panorama, reduce memory requirement and get more fast calculation of 3D image on Scene.*

## The Lights group

First check the box **Enables light sources** in the group parameters.

The screenshot shows the 'Lights' parameter group with the following settings:

- Enable Light Sources
- Light Source Position:
  - Light Source Diam. (mm): 50
  - Interval (Parallel) (°): 5.73
  - Interval (Meridian) (°): 5.73
  - Range: Upper hemisphere
- Defocus Options:
  - Pupil Diameter (mm): 4
- Color Options:
  - Color Multiplier: 10
- Standard Lighting:
  - Enable Standard Lights

Once the **Enable light sources** check box is checked, you can generate light sources for the panorama. You can specify the light sources diameter and intervals between them. In accordance with your data input, the light sources will be placed all over the sphere automatically. Unfortunately it is not possible to choose light source positions individually, although you can choose whether to distribute light sources over the upper hemisphere only or the entire panorama.

You can also specify light sources blurring parameters and color multiplier.

Under **Standard lighting** subgroup you can specify if any of the standard lighting presets should be used.

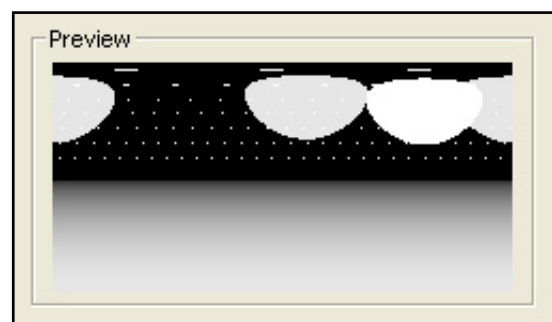





## The Hemisphere group

The Hemisphere group contains the **Enable light hemisphere** check box as its first element, which is initially unchecked. Checking the **Enable light hemisphere** check box allows generation of a synthetic panorama consisting of zones, as discussed later in the Zones Tutorial (see section **4.6 Making synthetic panoramas with zones**).

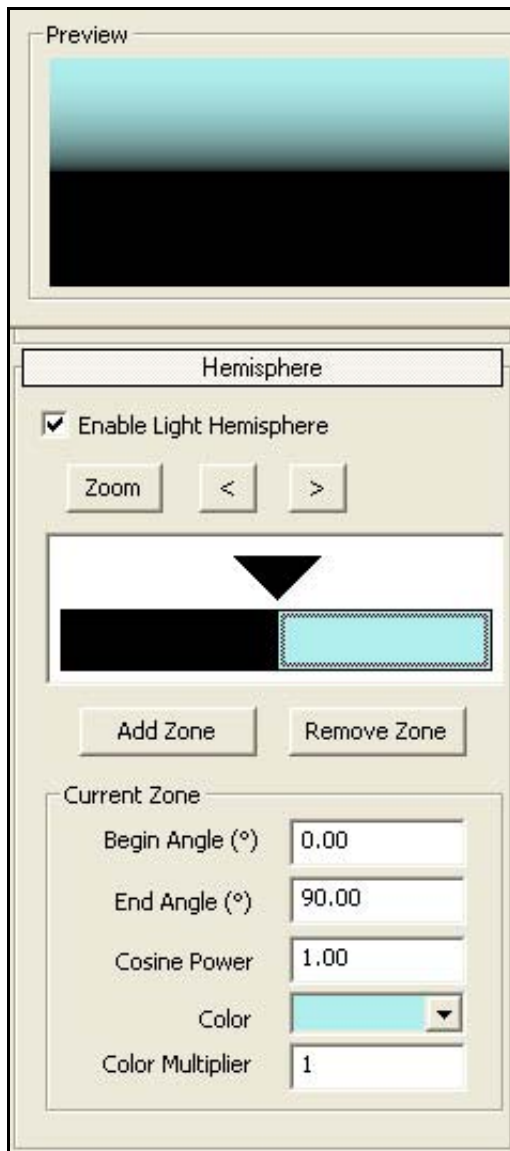

## The External group

External high dynamic range panoramas can be loaded in the **External** group.  
To load HRD panorama:

- Check **Enable external image**

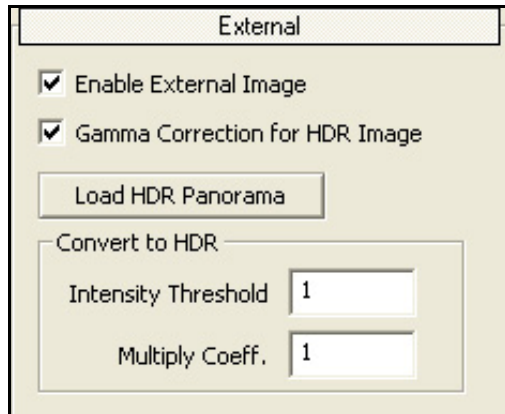

- Press button **Load HDR panorama**
- Select panorama image (hdr, jpg, bmp, tiff etc) in the **Open external panorama file** dialog window
- Press button **Open**
- Panorama preview appears in the **Preview** window



- Press button **Apply** or **OK** to except panorama

## Convert to HDR section

Then JPEG panorama file is loaded it is possible to use parameters in the section **Convert to HDR: Intensity Threshold** and **Multiply Coefficient**

All pixels with brightness more then **Intensity Threshold** are multiplied to the **Multiply Coefficient**. **Multiply Coefficient** increases brightness of the light sources. If the real picture contains not so bright light sources you can decrease parameter **Intensity Threshold** to make it not so bright. If the real picture contains a lot of bright areas not real light source and after conversion all became very bright you can increase **Intensity Threshold**.

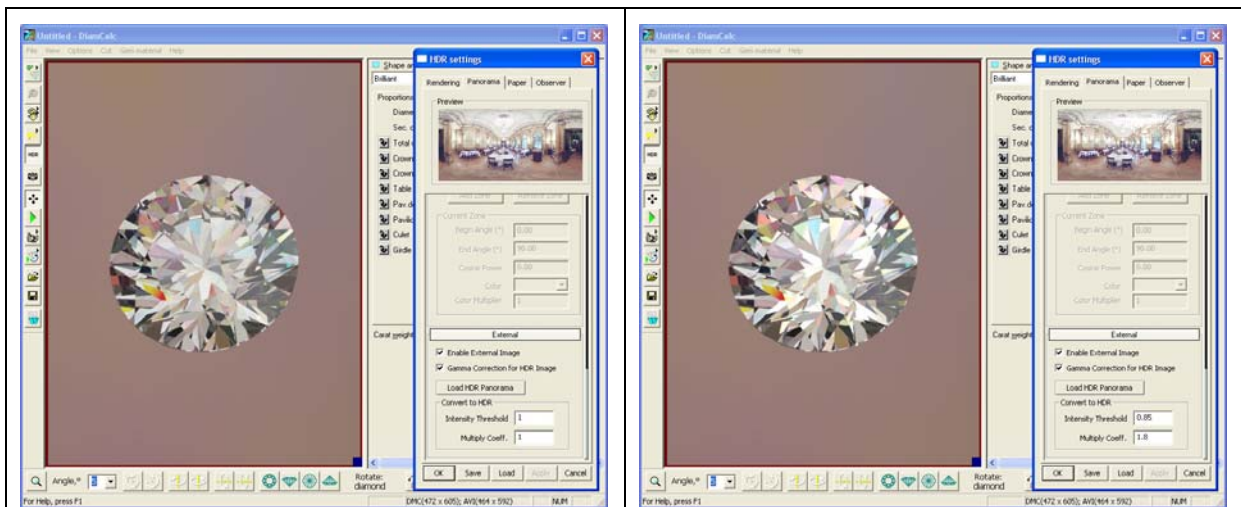

Default values:

Intensity Threshold = 1

Multiply Coefficient = 1



Modified values:

Intensity Threshold = 0.85

Multiply Coefficient = 1.8

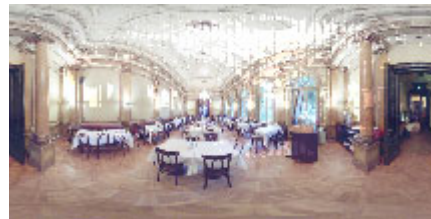

## 5.4 The Paper tab

The **Paper** tab allows to adjust the properties and look of the paper texture. The dialog lets to choose whether you want to use an existing picture of a real paper sheet or generate an artificial grid.

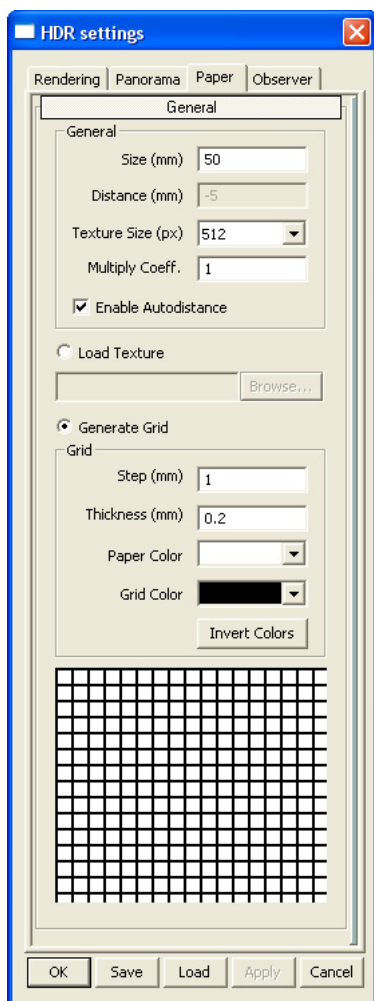

The **General** settings group allows to adjust the paper sheet options as it appears in the rendering window.

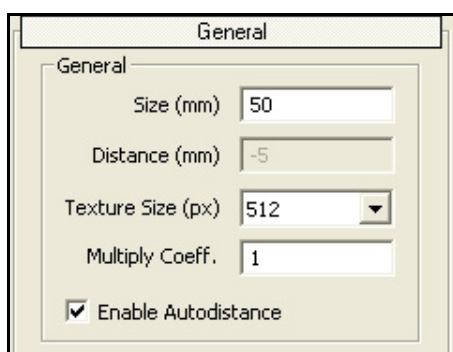

The **Size** setting affects the size of the paper rectangle.

**Distance** determines the paper offset relative to the gemstone position. Negative  $n$  value moves the paper to  $n$  millimeters behind the gemstone. For instance, the value of -5.00 shown in the screenshot, places the paper five millimeters behind the stone.

The **Texture size** setting determines how big the paper texture will be. The bigger texture — the more details (providing the original image is at least as big as the selected texture size, in case of external picture use).

To load texture select button **Load Texture** and select a file with texture

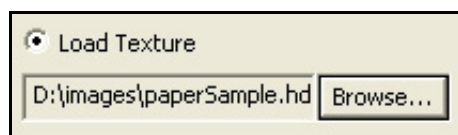

Press button **Apply** to see result.

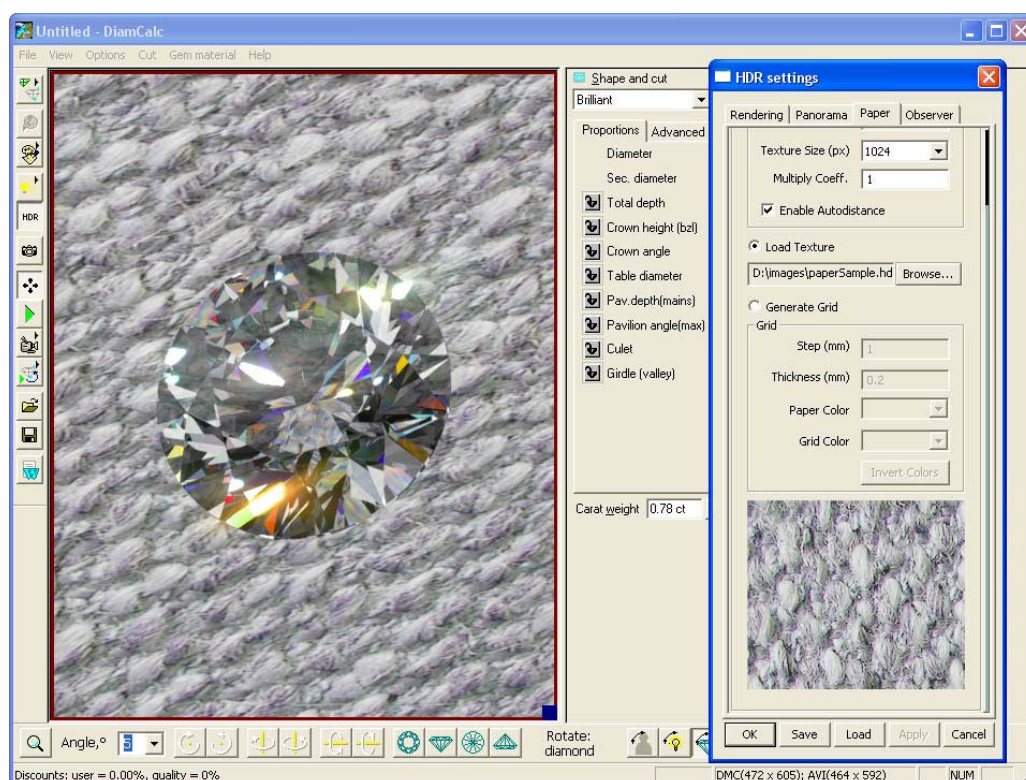

To generate a squared paper imitation grid select button **Generate Grid**

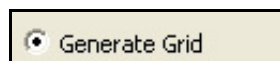

Set the grid options in the section **Grid**

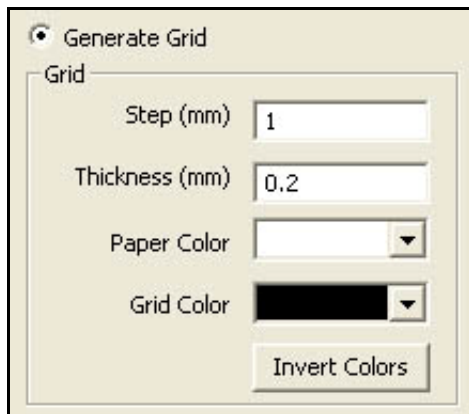

Press button **Apply** to see result

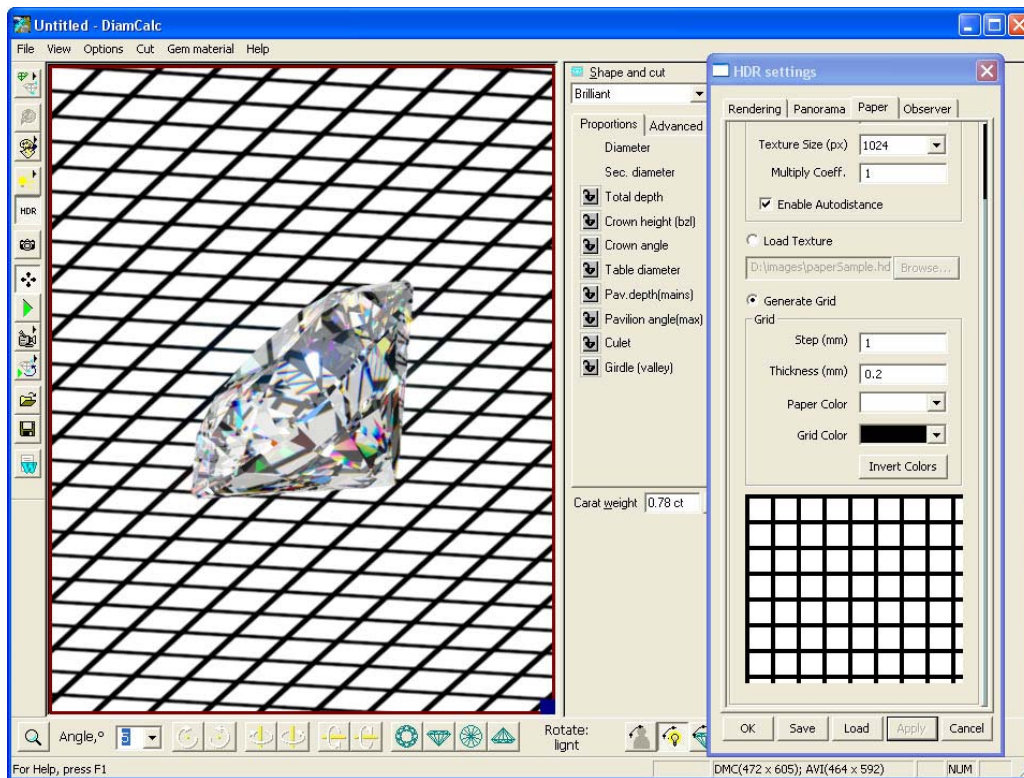



## 5.5 The Observer tab

The Observer tab contains controls responsible for the observer image, position and posture parameters, as well as the eyes position and shoulder line setting.

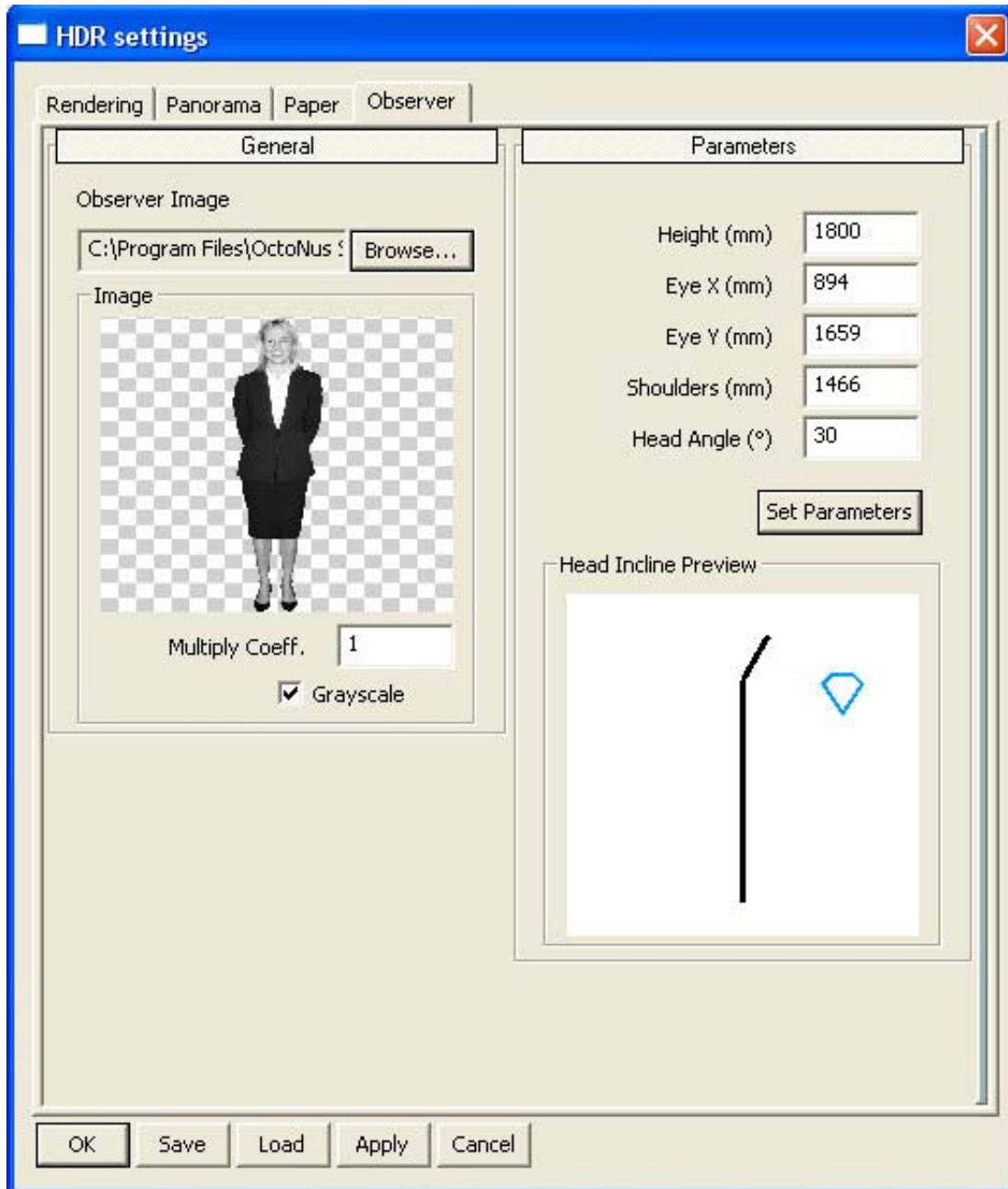

To load an external observer picture press **Browse** and choose a PNG file:

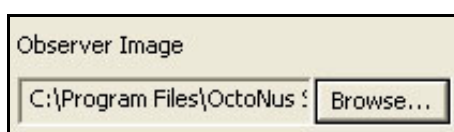

To set observer parameters, such as the observer height, eyes position, shoulder line position and head incline angle use the settings in the **Parameters** group:

The image shows a dialog box titled "Parameters" with the following fields and values:

Height (mm)	1800
Eye X (mm)	894
Eye Y (mm)	1659
Shoulders (mm)	1466
Head Angle (°)	30

Below the fields is a button labeled "Set Parameters". Underneath is a preview window titled "Head Incline Preview" showing a vertical line that bends at the top at an angle, with a blue diamond icon next to it.

For additional settings press button **Set Parameters**



Use intuitive graphical dialog **Observer Parameters** to set parameters

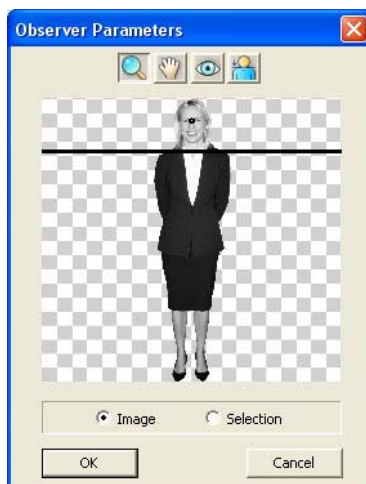

Make sure you're in **Image** mode

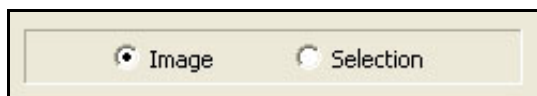

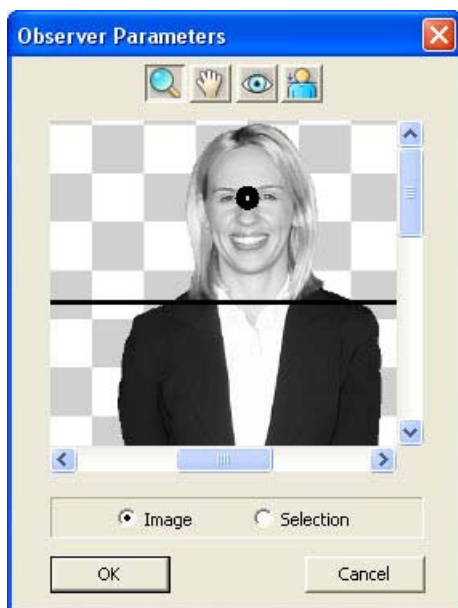

Select button with loop  to Zoom in and Zoom out



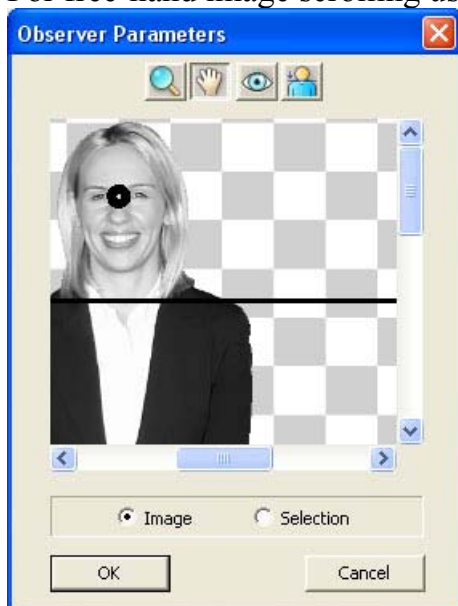

Use left click zooms in, while right click zooms out

For free-hand image scrolling use button with hand icon 

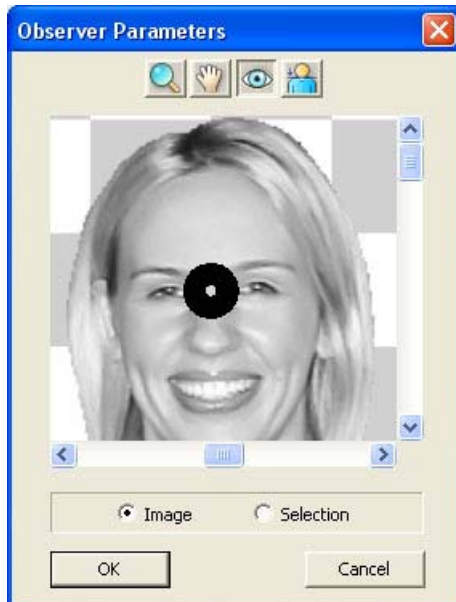

To set eyes position press eye-labeled button  and left click on the specific point on the observer image where the eye point to be placed (normally this point should be between the eyes of the observer):



To set shoulders position press button with a shoulder line pictogram  and place the line by left clicking on the observer image where the shoulders should be.

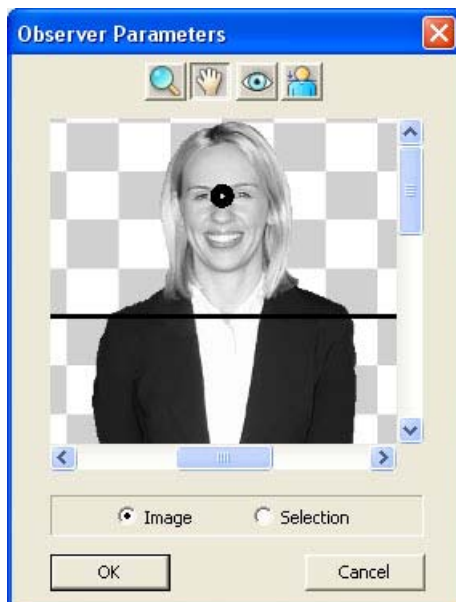



To learn about the current image transparency mask choose the **Selection** mode. This should be particularly handy for BMP images.

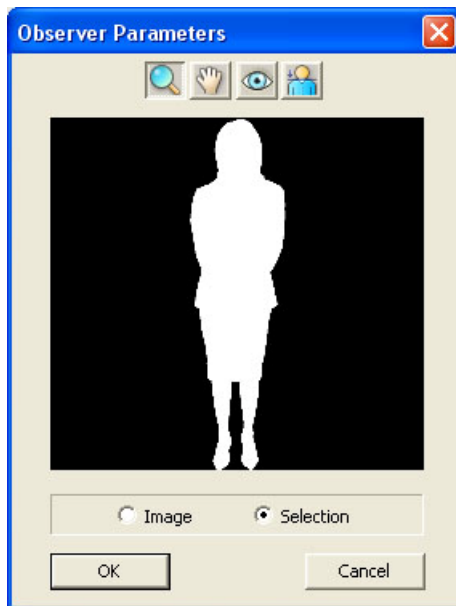

## 5.6 Making a synthetic panorama with zones

### Step 1: Beginning

The settings in the **Hemisphere** group of **Panorama** tab allows to control *Hemisphere* light

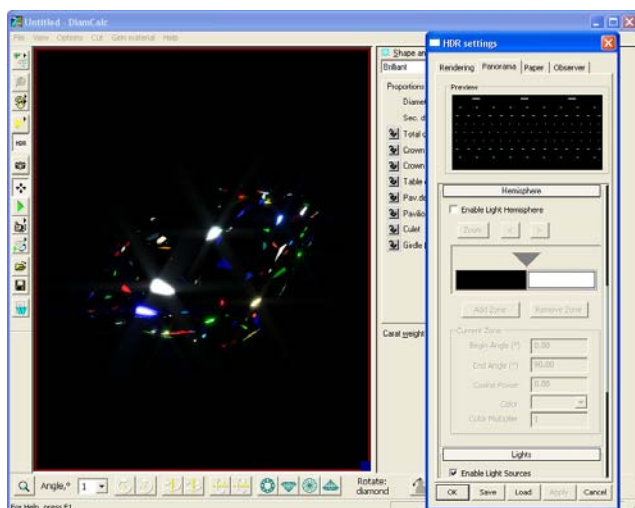

Hemisphere light is switch off

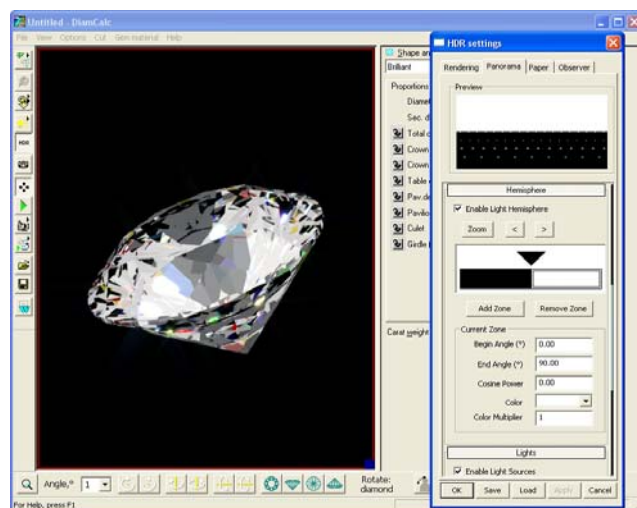

Hemisphere light is switch on

To enable Hemisphere light check the **Enable light hemisphere** check box in the **Hemisphere** group of **Panorama** tab:

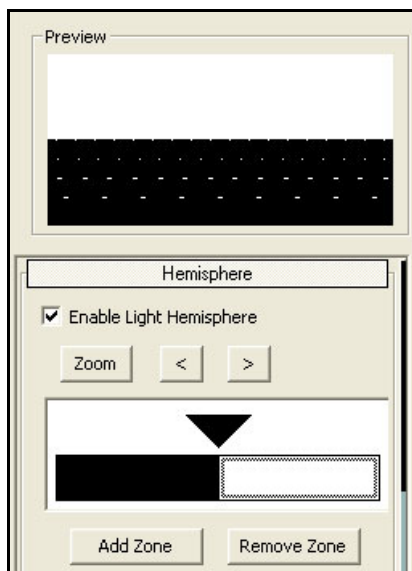

The *left side* of the white / black diagram is the *lower part* of the Hemisphere and the *right side* is the *upper part* of the Hemisphere.





## Step 2. Configuring zone

There are two zones available by default: the one on the right and the one on the left. To select the leftmost zone left click on the left zone:

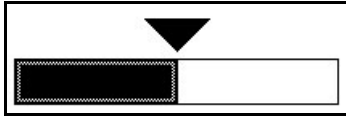

The section **Current Zone** contains the control options for the currently selected zone:

- Begin Angle
- End Angle
- Cosine power
- Color
- Color multiplier

To change the color of zone:

- Press drop-down list arrow for the option **Color**:



- Select a color

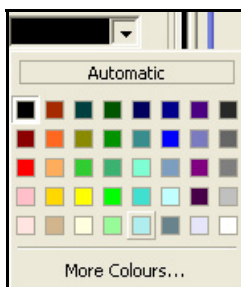

- The new color displays on **Preview** window and zones diagram:

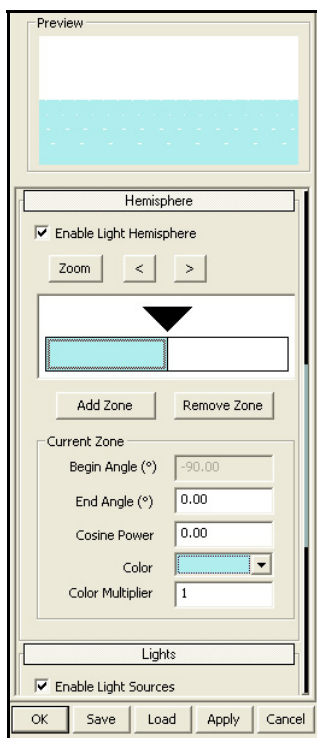

- Press button **Apply**  at the bottom of the **HDR Settings** dialog to generate the panorama and see result on Scene

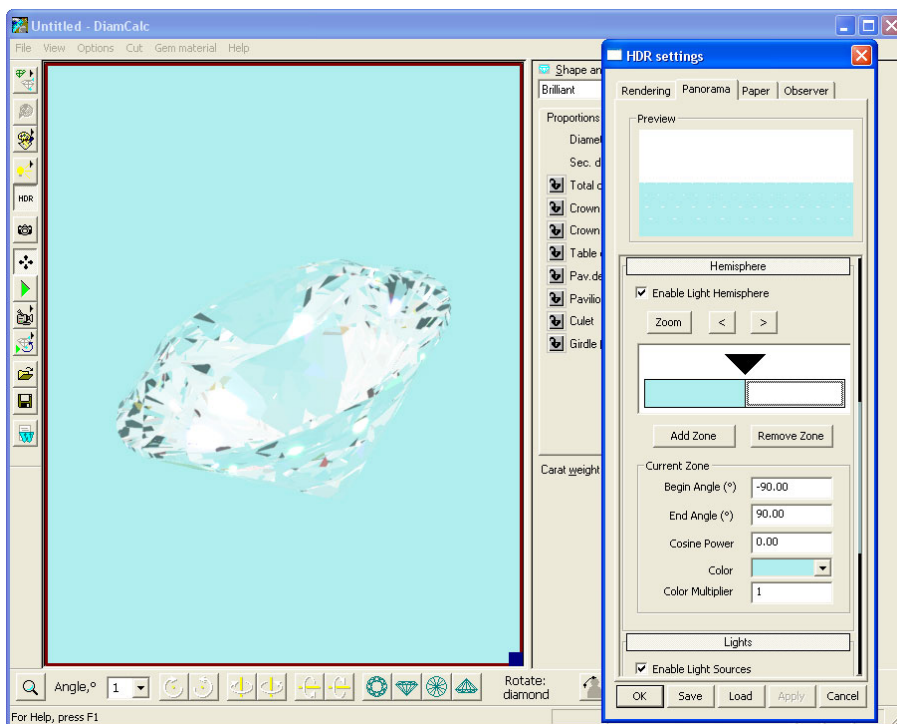

Change *cosine power*, for example, set **Cosine power** value in the section **Current zone** to **2.00**

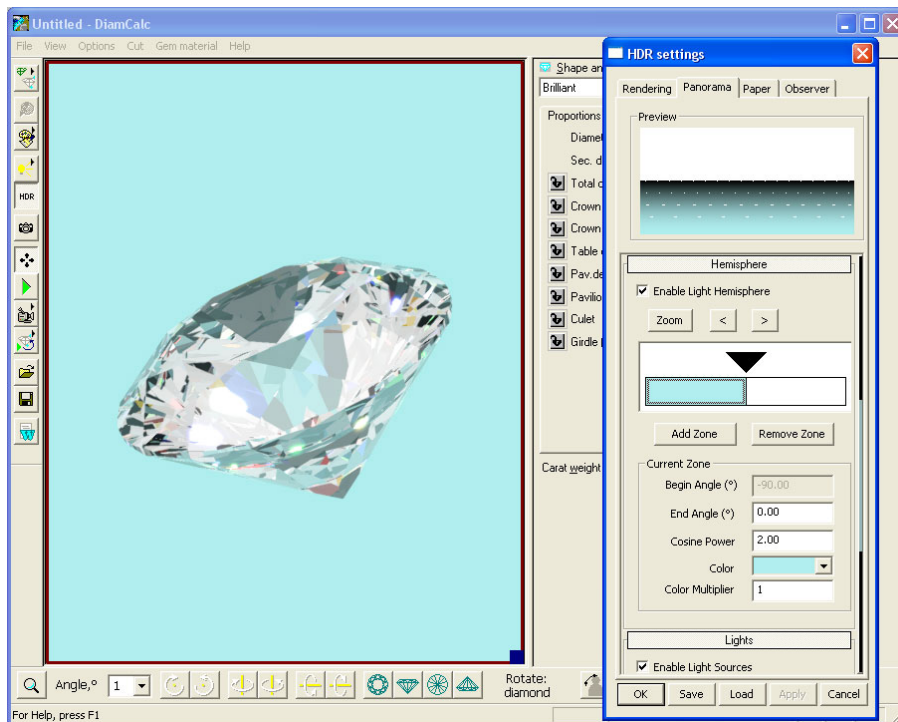

Change *Color Multiplier*, for example, set **Color Multiplier** value in the section **Current zone** to **0.50**

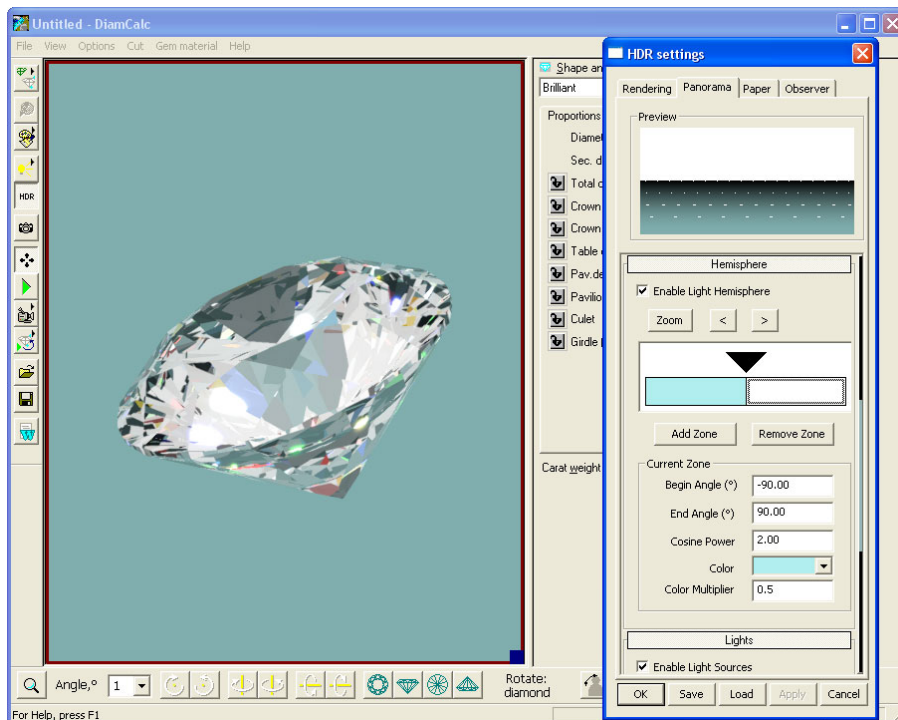

### Step 3. Configuring an inner zone border

To configure inner zone border:

- Click on triangle ▼ in the zones diagram

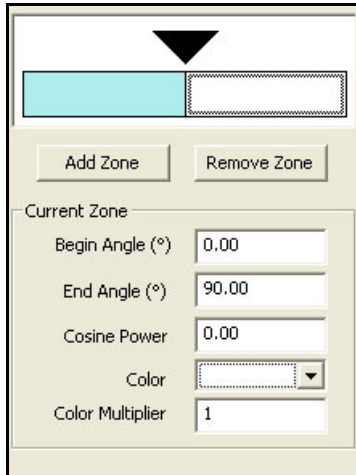

The screenshot shows a control panel for zone configuration. At the top, a black triangle points downwards towards a horizontal bar divided into a light blue section on the left and a white section on the right. Below this bar are two buttons: "Add Zone" and "Remove Zone". Underneath is a section titled "Current Zone" containing several input fields: "Begin Angle (°)" with the value 0.00, "End Angle (°)" with the value 90.00, "Cosine Power" with the value 0.00, "Color" with a dropdown menu, and "Color Multiplier" with the value 1.

- Move triangle to make the zone smaller or larger

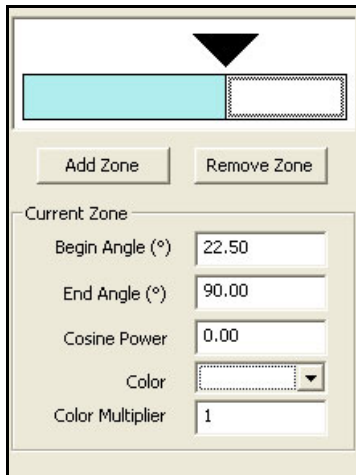

This screenshot is identical to the previous one, but the black triangle is now positioned further to the left, pointing to a smaller light blue section of the horizontal bar. The "Current Zone" settings below remain the same: Begin Angle (°) 22.50, End Angle (°) 90.00, Cosine Power 0.00, Color dropdown, and Color Multiplier 1.

The second way of changing the angle of the inner zone border: just click on the zone and hold the mouse button down while moving the mouse cursor to a position where the zone should be placed.

The third way of changing the angle of the inner zone border is to type the value between -90 and 90 degrees into the text box:

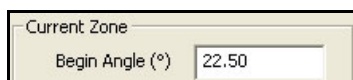

A close-up view of the "Current Zone" section, specifically the "Begin Angle (°)" input field, which contains the numerical value 22.50.

When a new value for the Border parameter is entered the inner zone border and triangle change its positions on the zones diagram automatically.

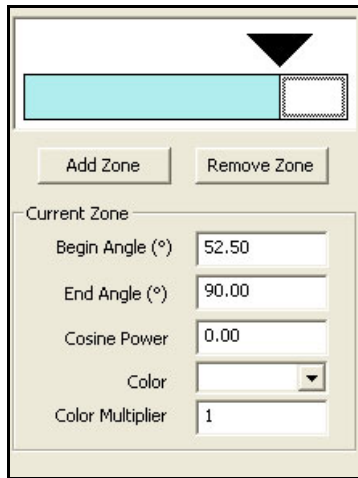

To see result on Scene press button **Apply**  at the bottom of the **HDR Settings** dialog to generate the new panorama

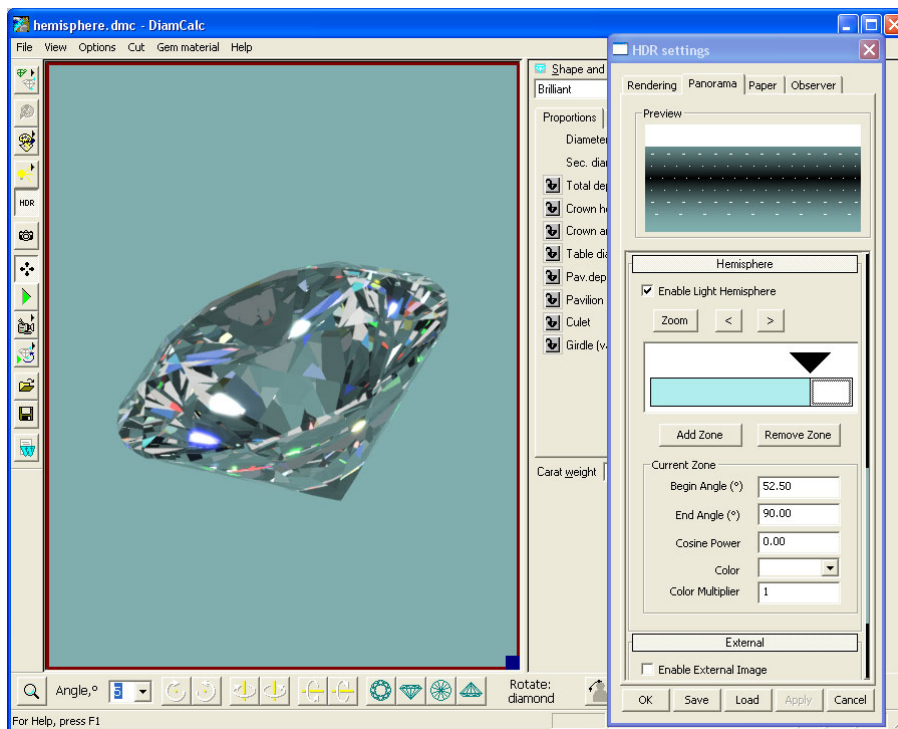



## Step 4. Adding new zones

To add a new zone to the panorama

- Press button **Add Zone**:

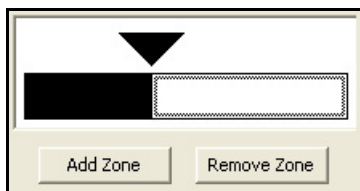

- New zone appears:

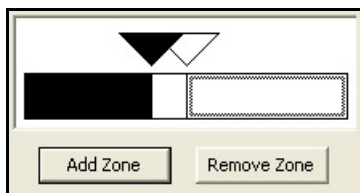

All new zones appear in 0.0 degrees position with white color and the default values for cosine power and color multiplier parameters.

- Click on mouse to select the new zone

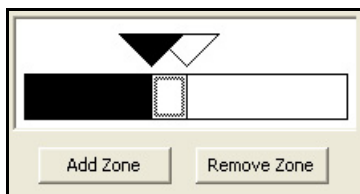

- Select a color for new zone or change other options (see step 2. Configuring zone)

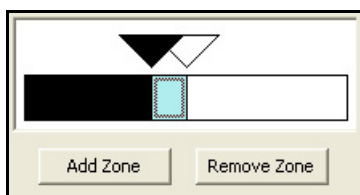

- Move new inner zone border (see step 3. Configuring an inner zone border)

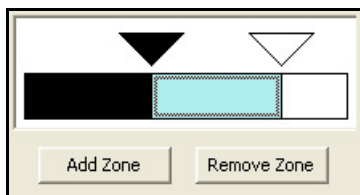



The result of adding new zone:

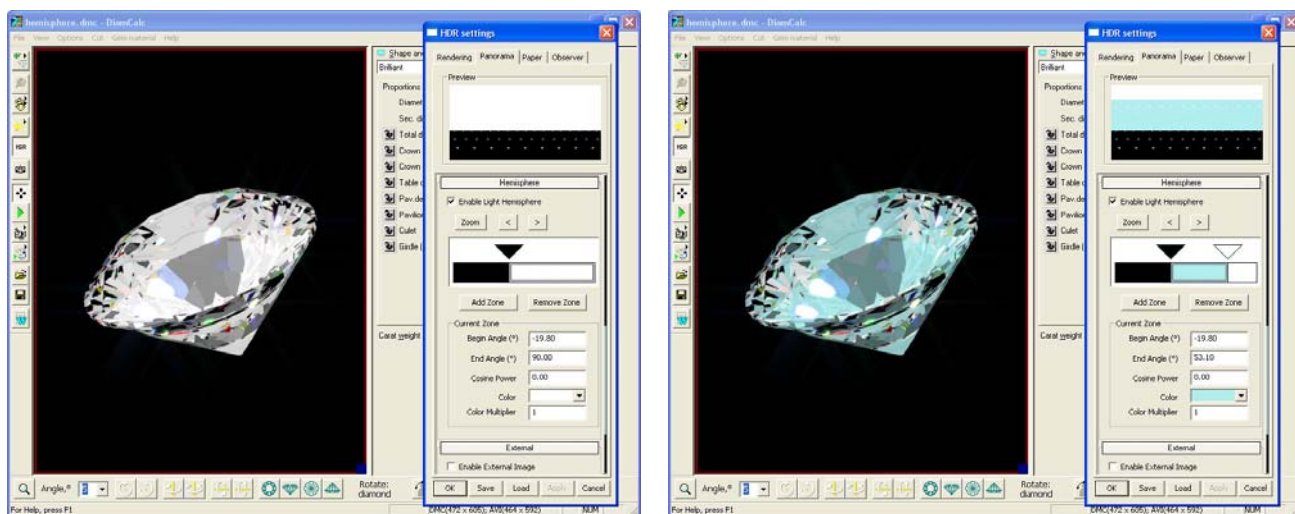

Two zones

Three zones

If press **Add Zone** button twice or several times the new zones will be placed above the one added before. Configure it. The maximum quantities of zones are 8:

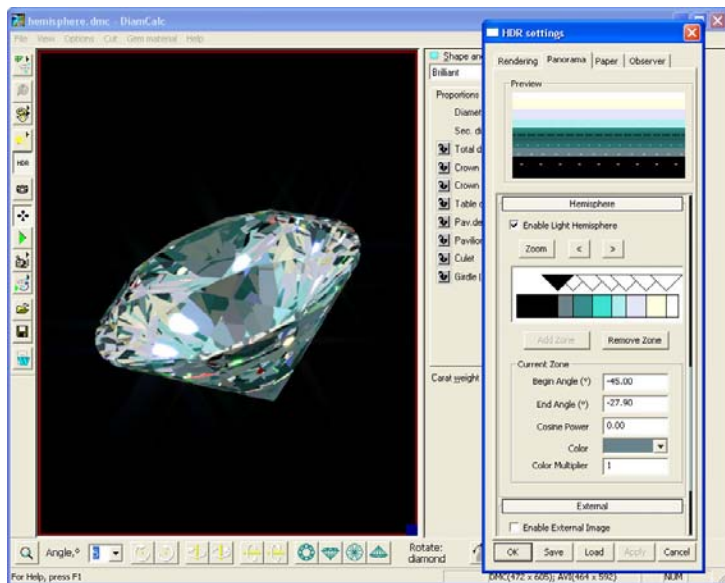

If two triangles are placed close –see how many triangles are there in one place:

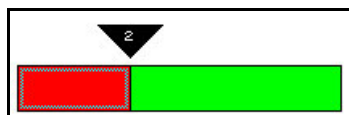

If move the border or the triangle – the zone behind these two zones will appear inside:

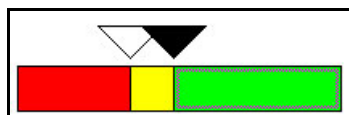



## Step 5. Navigate between the zones

To switch between the zones use control buttons:



These buttons is useful if there are a lot of zones:

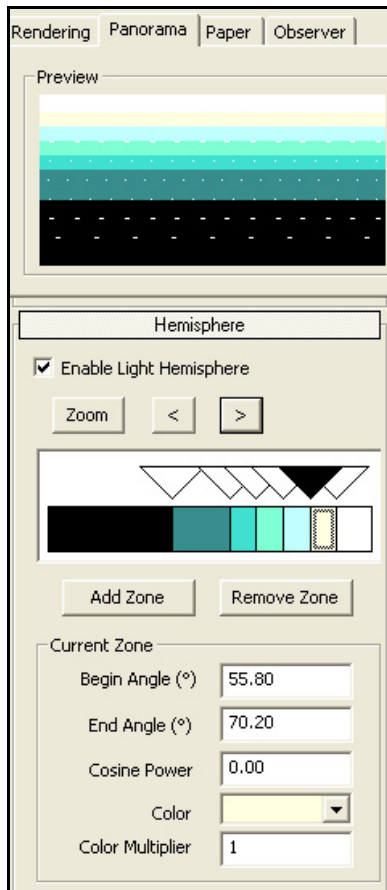

Also use Hot keys to switch between the zones **Ctrl + <-** and **Ctrl + ->**

## Step 6. Zoom zones control

Zoom of Zones control section is useful if there are a lot of thin zones.  
To zoom Zones control section:

- Press button **Zoom** Zoom in the section **Hemisphere**

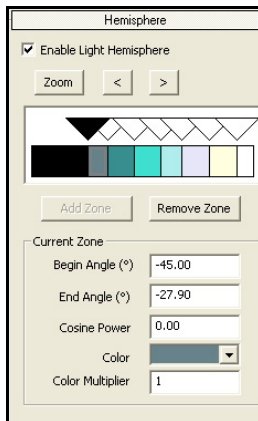

- The new separate window **Light Hemisphere** appears.

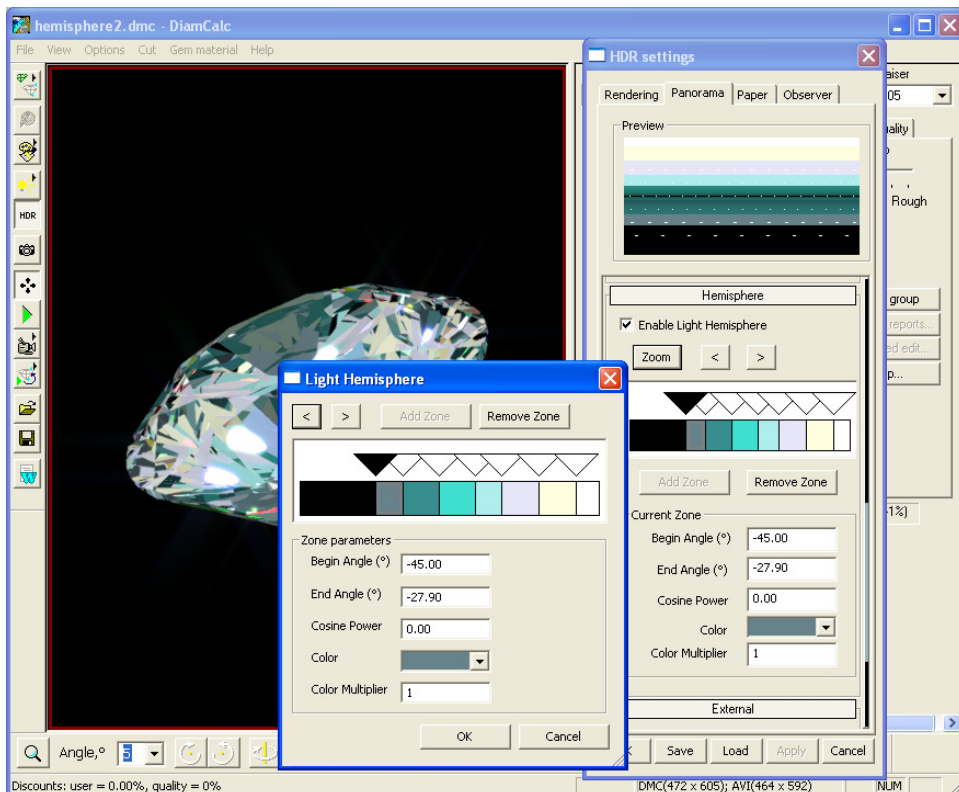

- Make changes in the Zones control
- Press **OK** to apply changes

## Step 7. Removing the zone

To remove the zone:



- Left click inside the zone to select it. For example, select red zone:

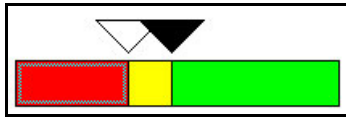

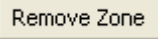
- Press button **Remove Zone** 
- Red zone is removed

It is possible to remove all zones except for the leftmost zone (i.e. the one that has its border angle fixed to  $-90$  degrees).

## 5.7 Creating High dynamic range (HDR) panorama by third-party software

It is possible to create High dynamic range panorama for DiamCalc using any editor supports 32-bit per channel color mode.

For example, use:

- Adobe Photoshop CS3 Extended (<http://www.adobe.com/downloads/>)
- Adobe Photoshop CS (<http://www.adobe.com/downloads/>)
- Artizen HDR (<http://www.supportingcomputers.net/>)

### The idea of mapping an image onto the sphere

The panorama image used for DiamCalc should be in *equidistant cylindrical projection*, more commonly called a *cylindrical map*. The image is wrapped onto the sphere.

DiamCalc load panorama image like this:

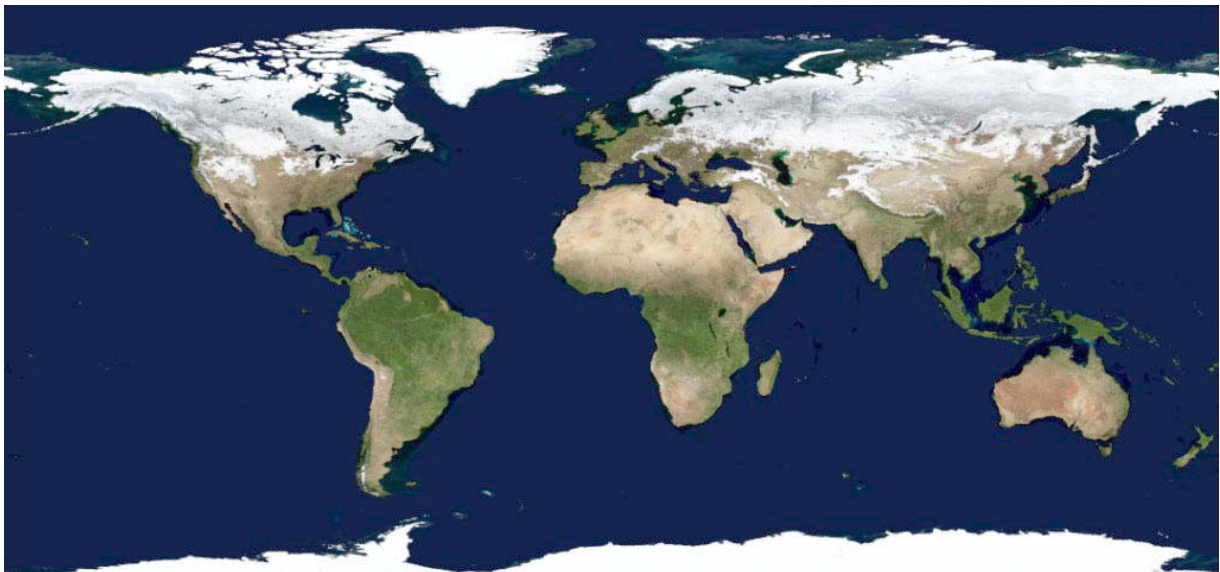

And we get the environment of the diamond where a diamond is inside this sphere:





Here is an example of creating your own HDR panorama

1. The top hemisphere should look like this:

2. And the bottom hemisphere is black:

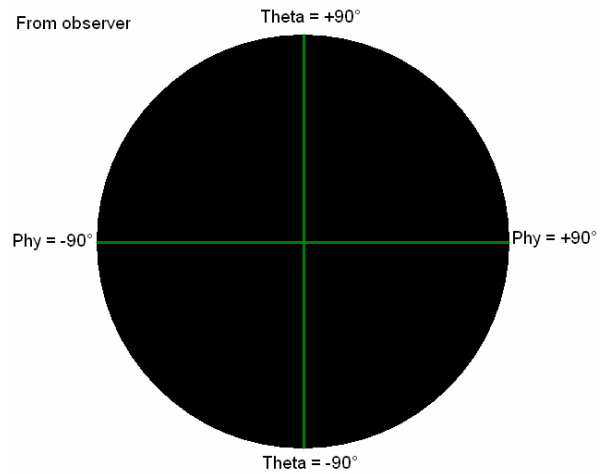
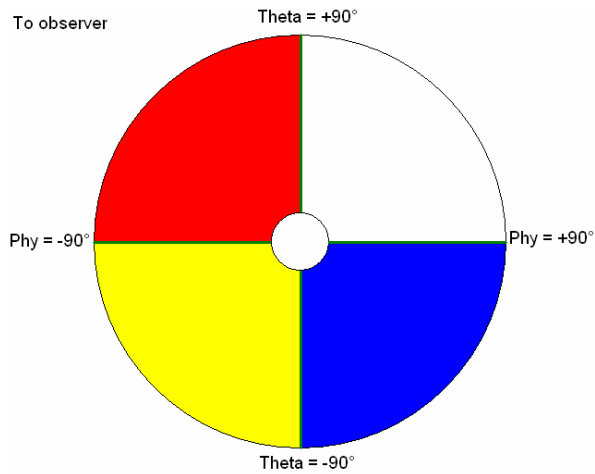

\*(green lines show the axis)

3. Then the panorama image will be:

4. When your image wrap the sphere, it looks like this:

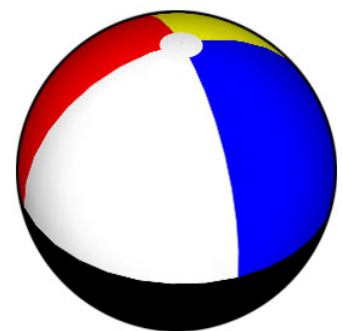
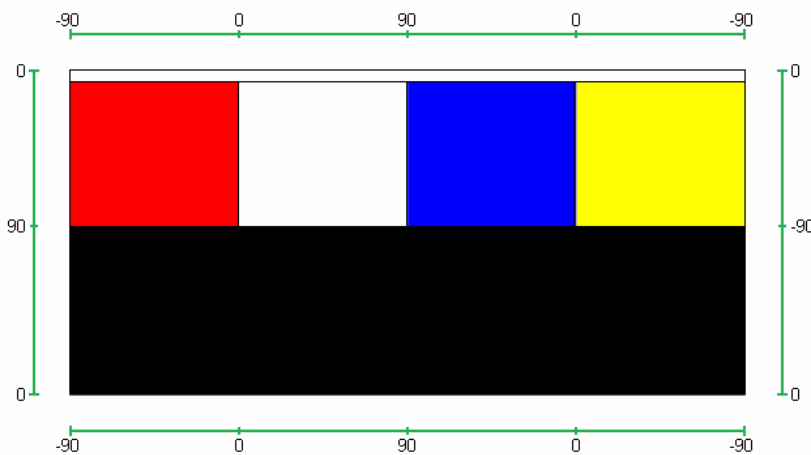



## Adobe Photoshop CS3 Extended

1. Choose from menu **File / New...**

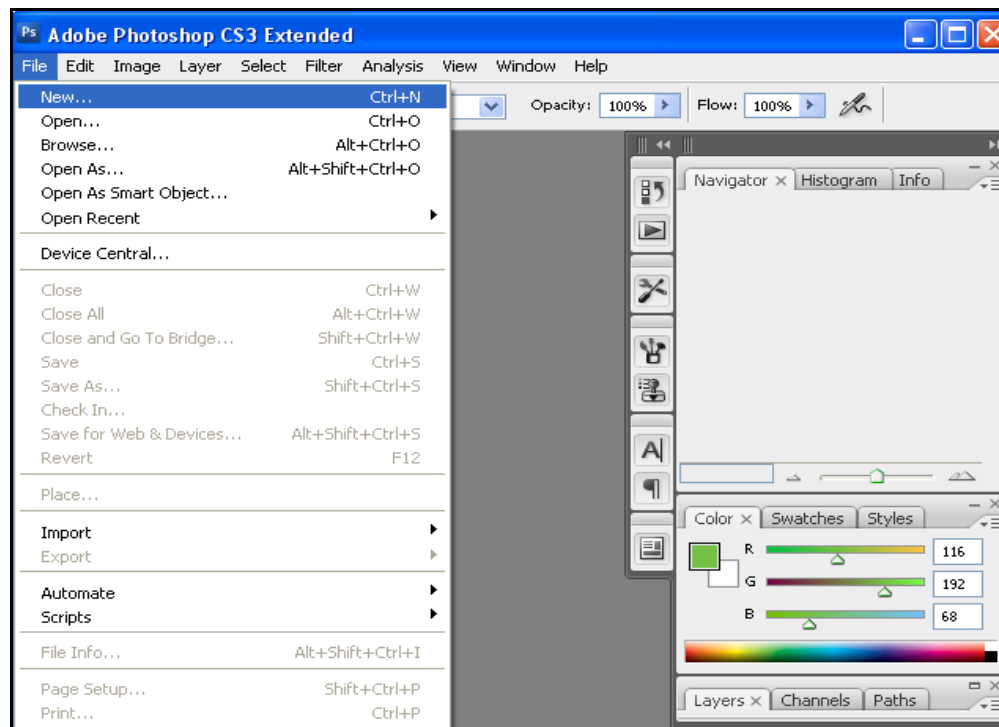

2. The dialog box with new image options appears

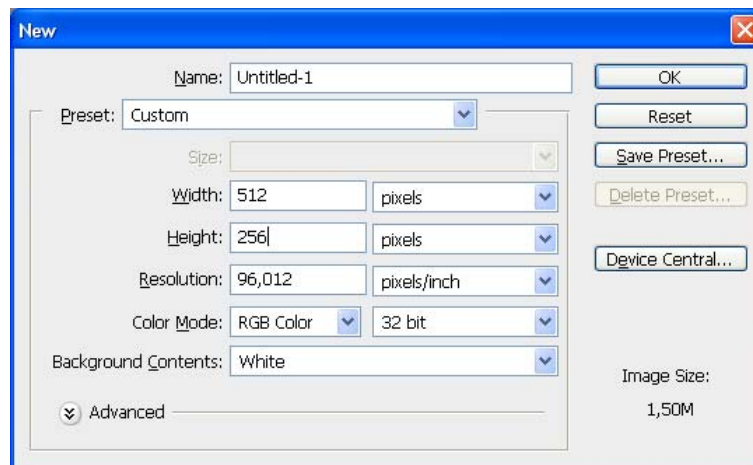

3. Change **Width** and **Height**. Remember that height should be two times less than weight, but of them should be power of 2 (such as 1024x512, 512x256 etc.)
4. Be sure that **Color Mode** is set to **RGB Color** and **32 bit**
5. Press **OK**
6. The blank image will appear
7. Edit it
8. When editing is finished save it in HDR file format:

- Choose from the menu **File / Save as...**

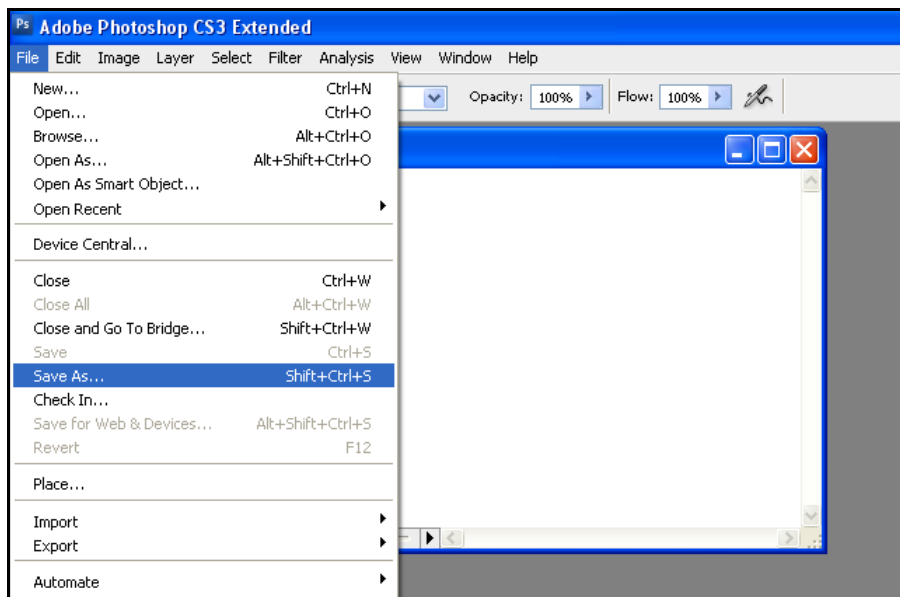

- The dialog of all supported formats appears
- Make sure, that HDR file format (\*.HDR) is chosen

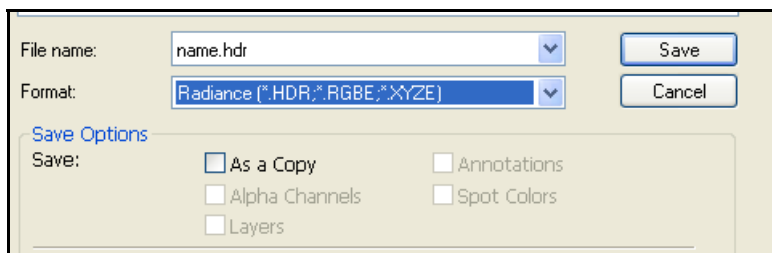

- Press button **Save**

## Adobe Photoshop CS

Formally Adobe Photoshop CS can not create 32-bit per channel images, but it is possible to create 16-bit HDR and work with it. Most of the time it will work correctly, but for better result use Adobe Photoshop CS3 or other software, which can create 32-bit per channel images.

To create 16-bit HDR image:

1. Choose **File / New** from the menu panel

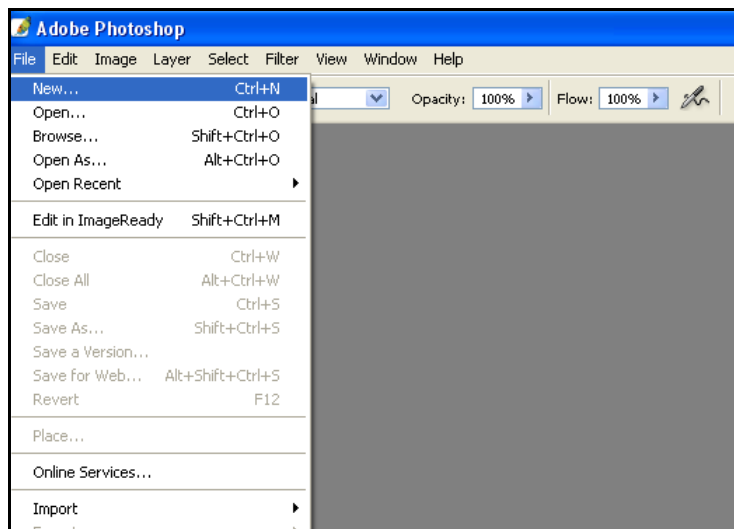

2. The dialog box with new image options will appear
3. Change Width and Heights. Remember that height should be two times less than weight, but of them should be power of 2 (such as 1024x512, 512x256, etc)
4. Be sure that **Color Mode** is set to **RGB Color** and **16 bit**

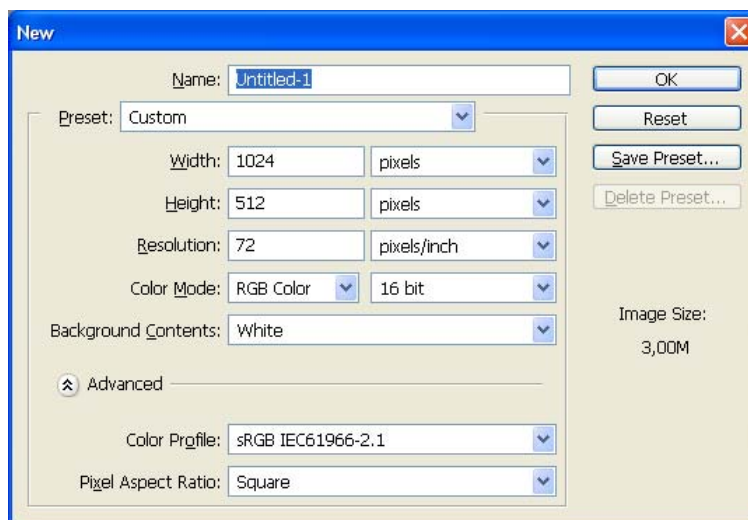

5. Press **OK**
6. The blank image appears
7. Edit it

9. When editing is finished save it in HDR file format:

- Choose from the menu **File / Save as...**

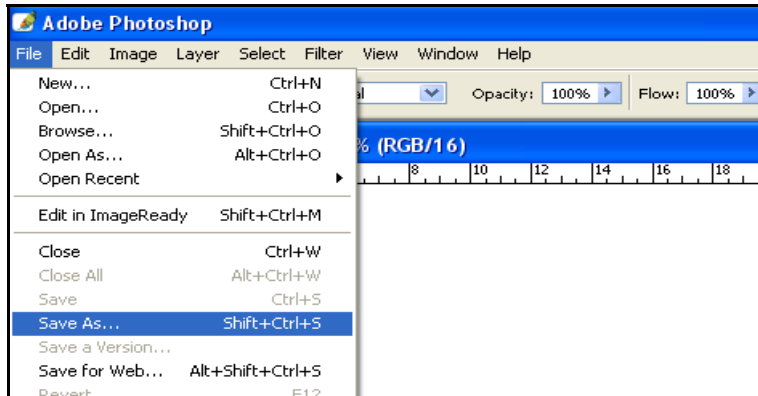

- The dialog of all supported formats appears
- Make sure, that HDR file format (\*.HDR) is chosen

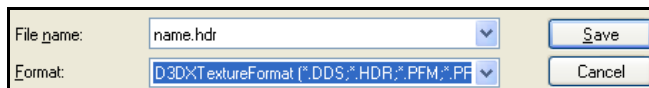

**Warning.** In Adobe Photoshop CS you should type *.hdr* at the end of the filename. If you forgot to do it *.dds* format will be set by default and it won't work with DiamCalc 3.0.

- Press button **Save**
- Dialog window **Please select texture type** appears

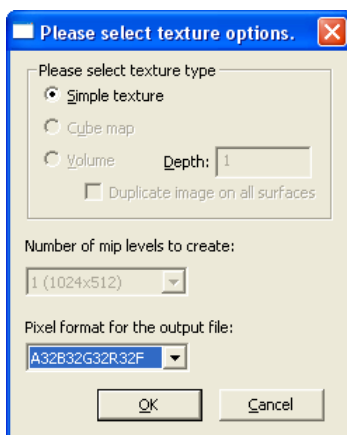

**Pixel format for the output file** should be **A32B32G32R32F**

- Press **OK**
- Select **Yes, scale between maximum values** in the dialog **Image scaling**

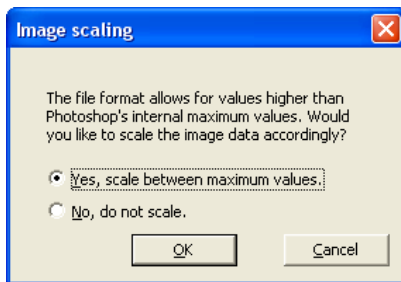

- Press **OK**

## Artizen HDR

1. Choose **File / From Scratch..**

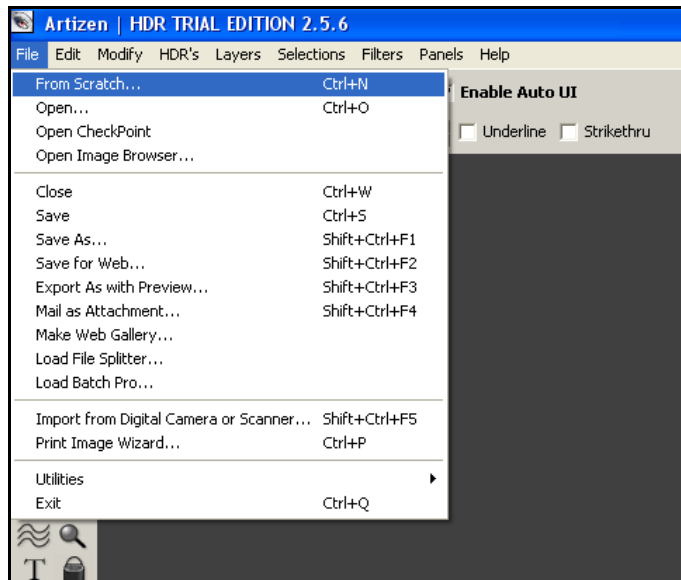

2. Dialog window **From Scratch** appears

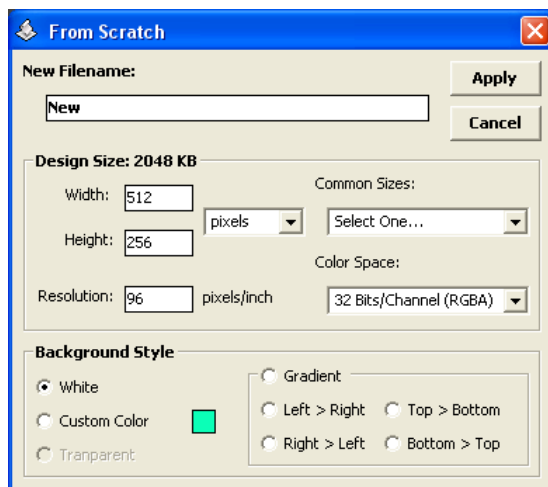

3. Set **Width**, **Height** and **Color Space**. Remember that height should be two times less than weight, but of them should be power of 2 (such as 1024x512, 512x256, etc.)
4. Color space should be **32 Bits / Channel (RGBA)**
5. Press button **Apply**
6. The blank image appears
7. Edit it
8. When editing is finished save it in HDR file format:
  - Choose from the menu **File / Save as...**

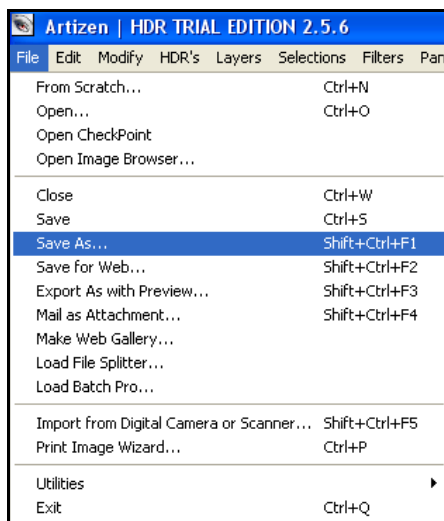

- The dialog of all supported formats appears

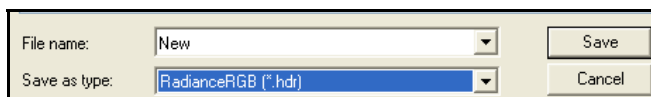

- Make sure, that HDR file format was chosen
- Press button **Save**.
- Set **Gamma Correction** to **2.2**

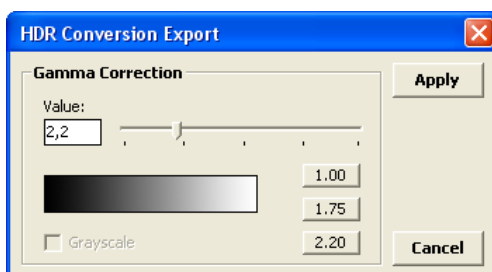

- Click button **Apply**



## 6 Creating Cuts with Cut Designer

### 6.1 Overview

Cut Designer allows constructing different types of cuts. For companies active in designing special cuts such as many Sightholders, Tiffany and Swarovski, the new cut designer tool enables creation of parametric models with tied proportions; each and parameters can be varied.

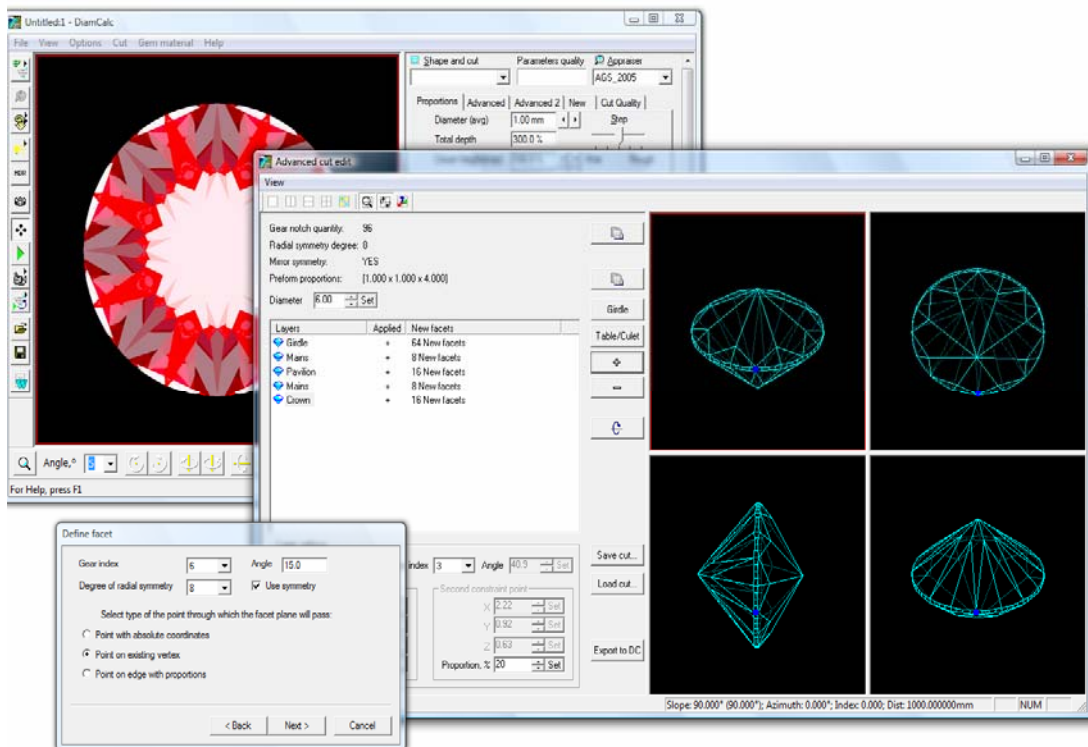

## 6.2 Getting started with Cut Designer

To work with Cut Designer select **Cut designer...** from menu **Cut**:

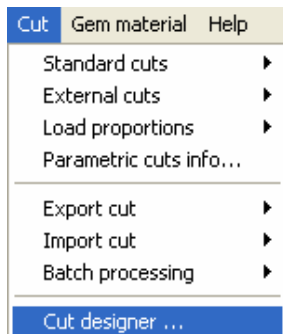

**Cut designer** appears.

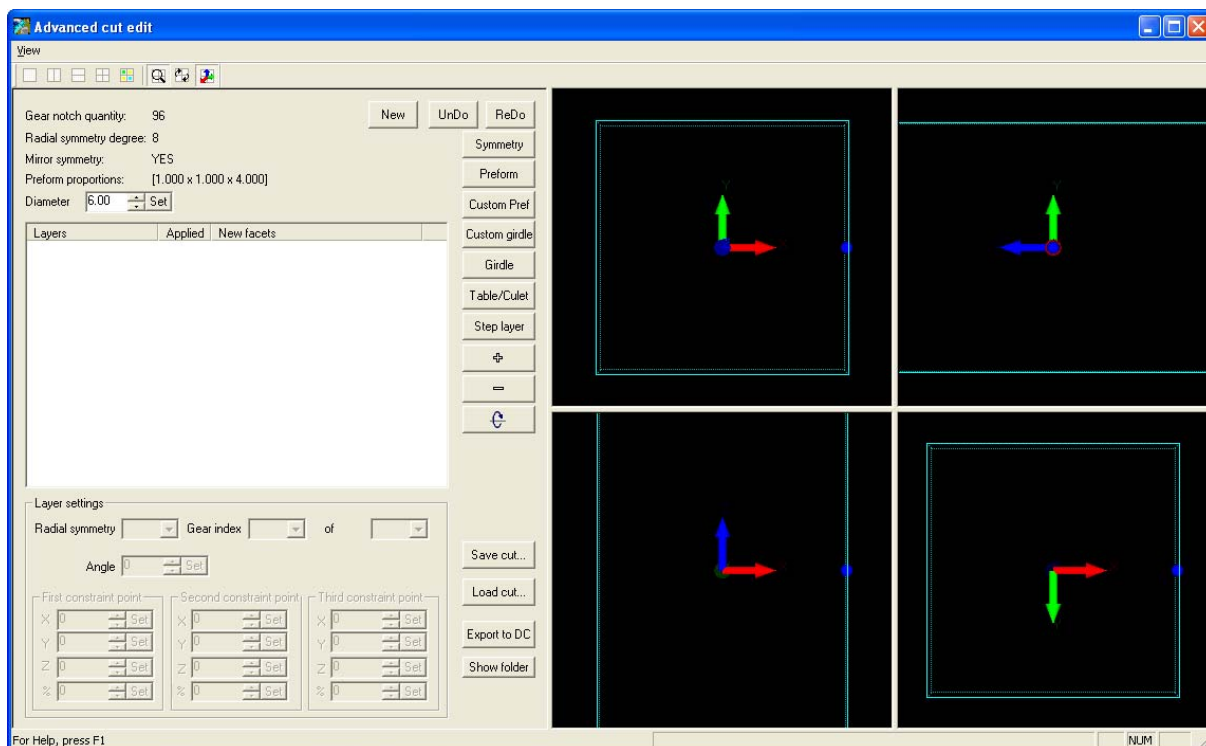





There are cut editor dialog window on the left side and model view on the right side.



The View panel allows switching different types of the model view, changing move and zoom options.



Types of model view:

-  Remove all splits of the model view
-  Split model view in two (vertical)
-  Split model view in two (horizontal)
-  Split model view in four

Move and zoom options:

-  Synchronize zoom factor in all view during changing
-  Rotate all view synchronously
-  Show coordinate system axes in all views

The general settings of cutting

Gear notch quantity:	96
Radial symmetry degree:	8
Mirror symmetry:	YES
Preform proportions:	[1.000 x 1.000 x 4.000]
Diameter	6.00 <input type="button" value="Set"/>

- Gear notch quantity
- Radial symmetry degree
- Mirror symmetry
- Preform proportions
- Diameter

To edit symmetry settings:

- Press button **Symmetry**: 
- Edit Gear notch quantity, Radial symmetry degree and Mirror symmetry

**Edit symmetry settings** ✕

Degree of radial symmetry

Gear notch quantity

Mirror symmetry

To edit Preform proportions:

- Press button **Preform** 
- Edit X dimension, Y dimension and Z dimension

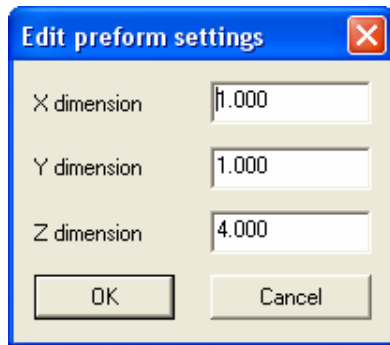

To build or edit cut use buttons **Custom girdle**, **Girdle**, **Table / Culet**, **Step layer**, **+**, **-** and **Flip**.



*Note.* Read the examples of creating **Brilliant**, **Princess**, **Gabrielle** and **Emerald** below.

To reset all settings and create new cutting press button **New** 

To undo and redo use buttons **UnDo** and **ReDo**  

To save and load cuts in XML format press buttons **Save cut...** and **Load cut...**

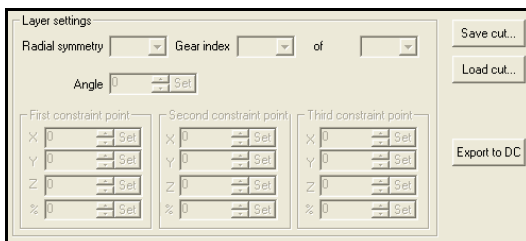

Button **Export to DC** allows export cut to DiamCalc main window. (See section **Save Cut, Load cut and Export to DC**).

### 6.3 Custom preform / Recut

Cut Designer allows to start creating cut using arbitrary 3D stone model as a *preform*. It is possible loading preform from DMC, ASCII, scanned MMD and others. This option can be used either for cut creating on the basis of existing cuts or as instrument for recutting design. Especially useful for recutting is the option of viewing the photorealistic image of the stone immediately during editing the model form.

To load preform - any diamonds shape into Cut Designer:

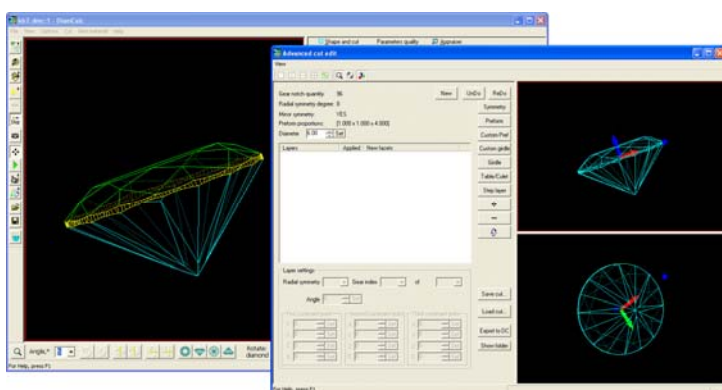

- Open file with desired preform in the DiamCalc main window
- Open Cut Designer
- Press button Custom Preform 
- Desired preform appears in the Cut designer window

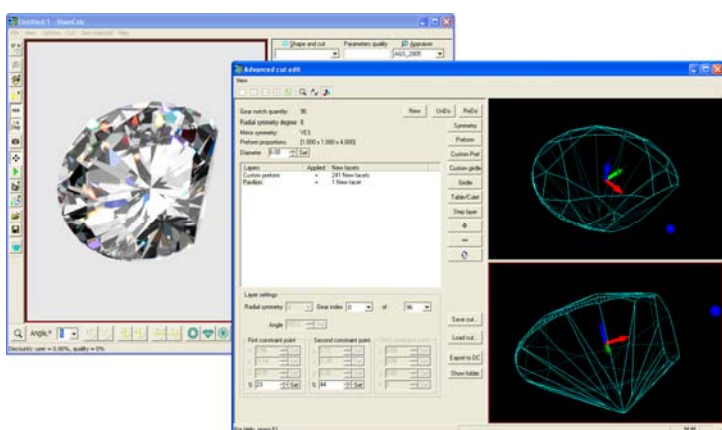

- Now work with loaded preform as usual
- It is possible while working in Cut Designer to view the photorealistic image of edited diamond



#### Restrictions:

- Button **Flip**  does not work with loaded preforms
- Some times using **Step Layer**  provides unexpected results for non convex shapes



## 6.4 Creating Brilliant cut

### General settings (as defaults)

Edit Symmetry Settings:

Degree of radial symmetry: **8**

Gear notch quantity: **96**

Mirror symmetry: **YES**

Edit Preform Settings:

X dimension: **1**

Y dimension: **1**

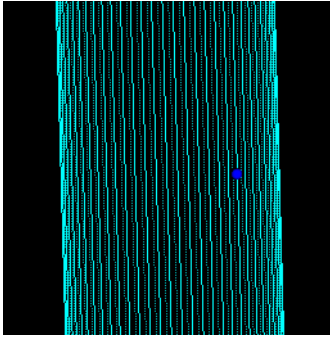
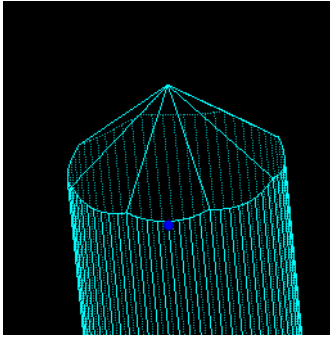

Z dimension: **4**

### Cutting Steps

Step	Result
<p>1</p> <p><input type="text" value="Girdle"/></p> <p>Gear index: <b>1</b></p> <p>Degree of radial symmetry: <b>32</b></p>	
<p>2</p> <p><input type="text" value="⊕"/> + Mains</p> <p>Gear index: <b>0</b></p> <p>Angle: <b>41</b></p> <p>Degree of radial symmetry: <b>8</b></p>	



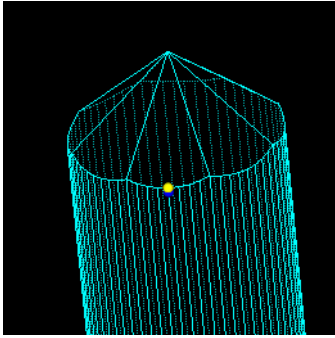
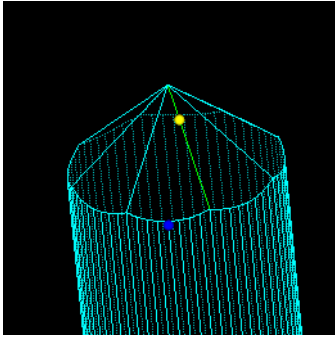
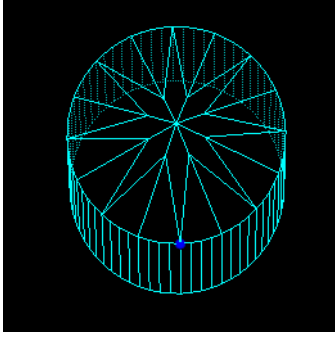

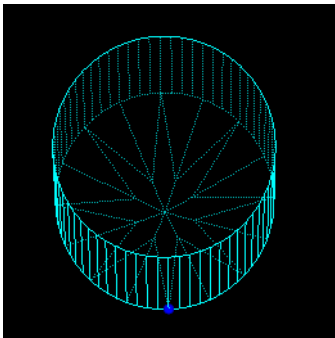
<p>3</p>	<p> + Facet through two points</p> <p>Gear index: <b>3</b></p> <p>Degree of radial symmetry: <b>8</b></p> <p>Use symmetry: <b>YES</b></p> <p>1st pt. Point on existing vertex.</p> <p>Select the vertex marked by blue point. Put on yellow point:</p>	
	<p>2nd pt. Point on edge with proportions.</p> <p>Select the edge point marked with yellow (Proportion value is about 70%):</p>	
	<p>Facets are ready:</p>	
<p>4</p>	<p></p>	

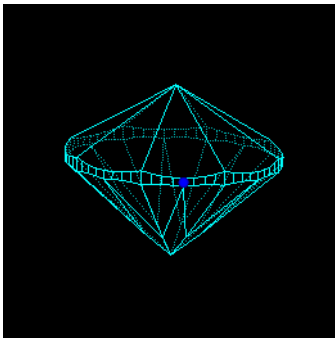
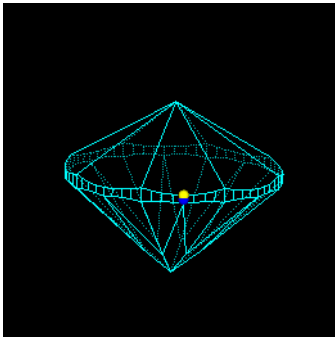
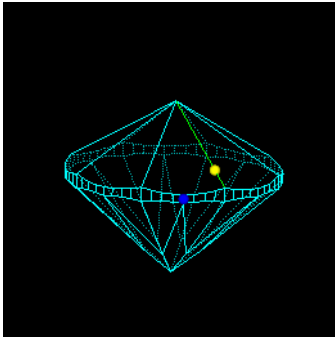
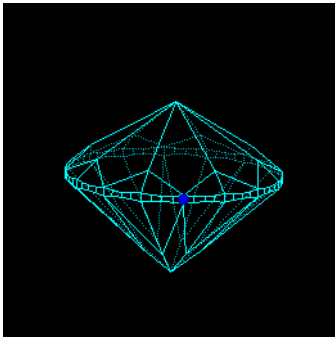

5	<input type="checkbox"/> + Mains  Gear index: <b>0</b> Angle: <b>33</b> Degree of radial symmetry: <b>8</b>	
6	<input type="checkbox"/> + Facet through two points  Gear index: <b>3</b> Degree of radial symmetry: <b>8</b> Use symmetry: <b>YES</b> 1st pt. Point on existing vertex. Select the vertex marked by blue point. Put on yellow point:	
	2nd pt. Point on edge with proportions.  Select the edge point marked with yellow (Proportion value is about 20%):	
	Facets are ready.	

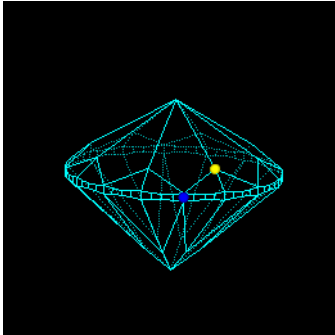
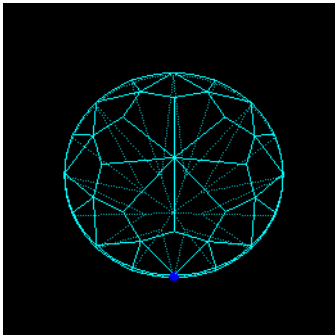
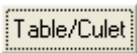
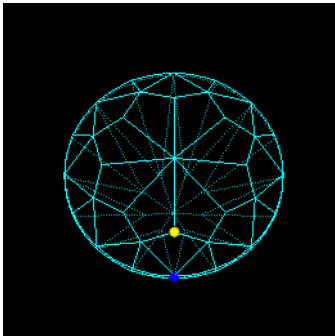
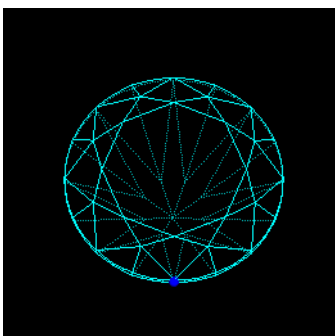

7	 + Facet through one point Gear index: <b>6</b> Angle: <b>15</b> Degree of radial symmetry: <b>8</b> Use symmetry: <b>YES</b> Point on existing vertex Select the vertex marked with yellow:	
	Facets are ready.	
8	 + Point on existing vertex Select the vertex marked with yellow:	
	Table is ready.	



- 9 Return to the 2nd step (Mains, 8 facets) and change Z-coordinate of First constraint point to **0.05**

Layer settings

Radial symmetry 8 Gear index 0 Angle 41.0 Set

First constraint point

X	3.00	Set
Y	0.00	Set
Z	0.05	Set
Proportion, %	0	Set

Second constraint point

X	0.00	Set
Y	0.00	Set
Z	0.00	Set
Proportion, %	0	Set

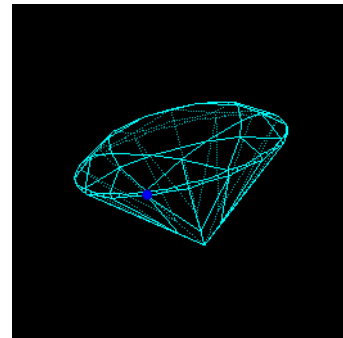

The cut is ready.

## 6.5 Creating Princess cut

### General settings

Edit Symmetry Settings:

Degree of radial symmetry: **4**

Gear notch quantity: **120**

Mirror symmetry: **YES**



Edit Preform Settings:

X dimension: **1**

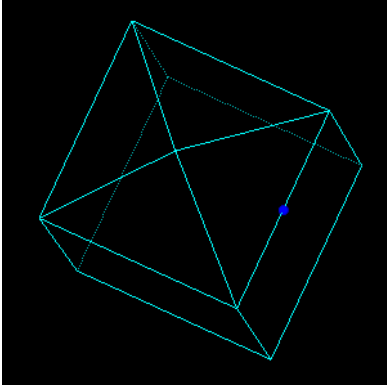

Y dimension: **1**

Z dimension: **4**

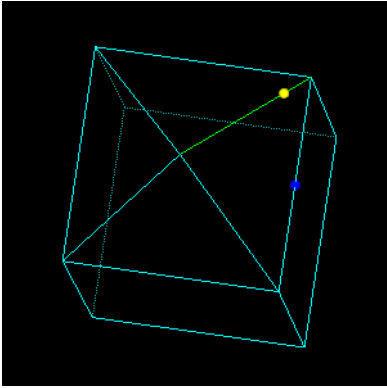
### Cutting Steps



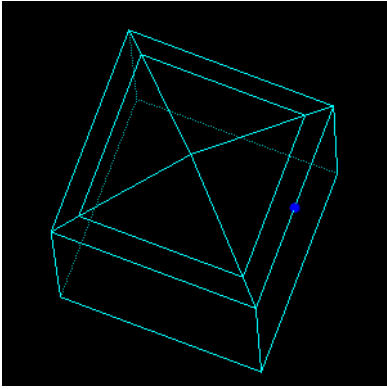

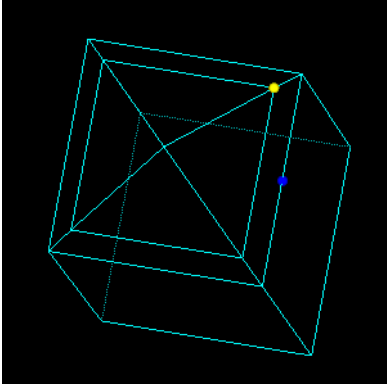
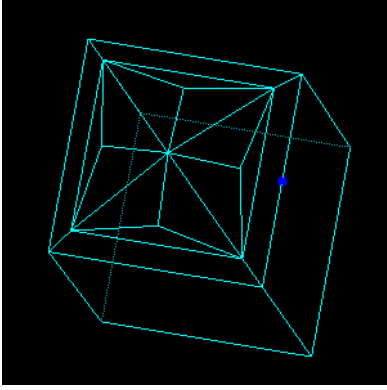
Step	Result
<p>1  + Mains</p> <p>Gear index: <b>0</b></p> <p>Angle: <b>45</b></p> <p>Degree of radial symmetry: <b>4</b></p>	
<p>2  + Facet through one point</p> <p>Gear index: <b>0</b></p> <p>Angle: <b>40</b></p> <p>Degree of radial symmetry: <b>4</b></p> <p>Use symmetry: <b>YES</b></p> <p>Point on edge with proportions</p> <p>Select the edge point marked with yellow (Proportion value is about <b>20%</b>):</p>	



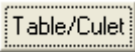
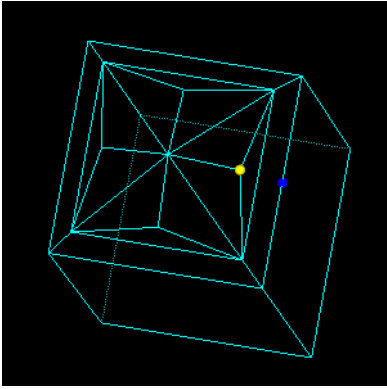
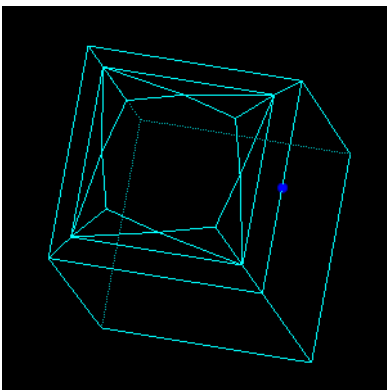

	<p>Facets are ready.</p>	
<p>3</p>	<p>  + Facet through one point            Gear index: <b>5</b>            Angle: <b>20</b>            Degree of radial symmetry: <b>4</b>            Use symmetry: <b>YES</b>            Point on existing vertex              Select the vertex marked with yellow:         </p>	
	<p>Facets are ready.</p>	

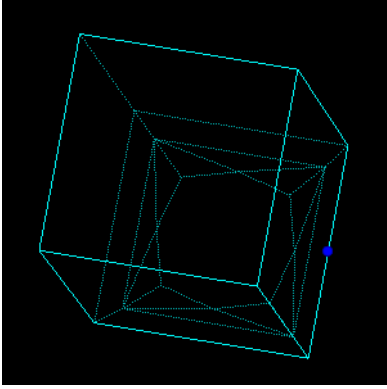

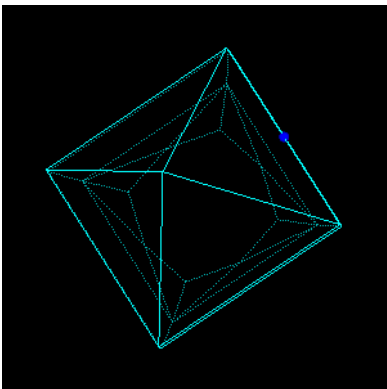

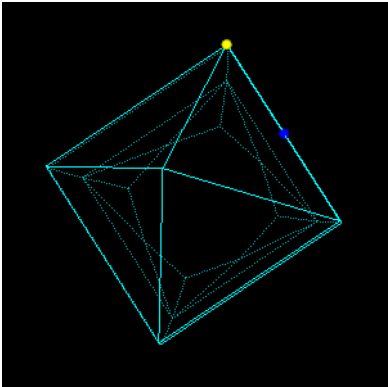
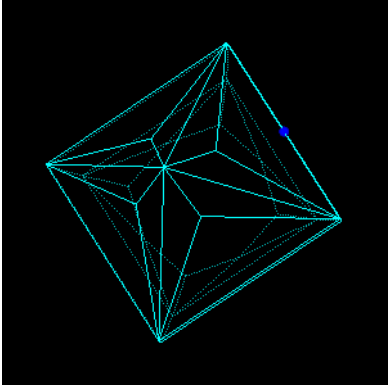

<p>4</p>	<p> + Point on existing vertex</p> <p>Select the vertex marked with yellow:</p>	
	<p>Table is ready.</p>	
	<p></p>	
<p>5</p>	<p> + Mains</p> <p>Gear index: <b>0</b></p> <p>Angle: <b>50</b></p> <p>Degree of radial symmetry: <b>4</b></p>	

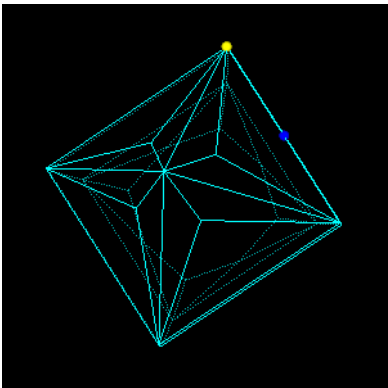

6	 + Facet through one point Gear index: <b>1</b> Angle: <b>47.5</b> Degree of radial symmetry: <b>4</b> Use symmetry: <b>YES</b> Point on existing vertex  Select the vertex marked with yellow:	
	Facets are ready.	
7	 + Facet through two points Gear index: <b>14</b> Degree of radial symmetry: <b>4</b> Use symmetry: <b>YES</b> <b>1st pt.</b> Point on existing vertex  Select the vertex marked with yellow:	

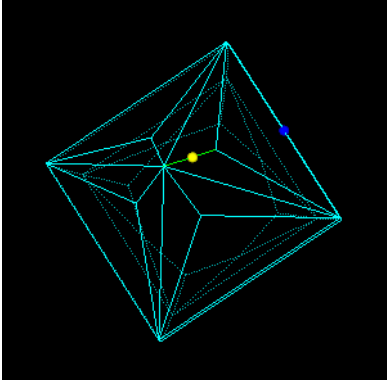
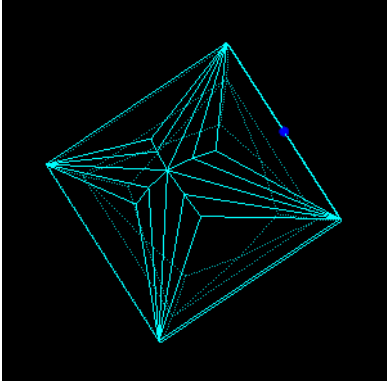

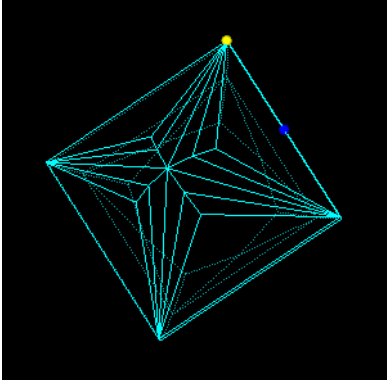
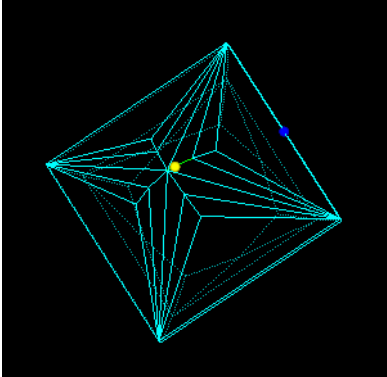
<p><b>2nd pt.</b> Point on edge with proportions</p> <p>Select the edge point marked with yellow (Proportion value is about <b>45%</b>):</p>	
<p>Facets are ready.</p>	
<p>8  + Facet through two points</p> <p>Gear index: <b>15</b></p> <p>Degree of radial symmetry: <b>4</b></p> <p>Use symmetry: <b>YES</b></p> <p><b>1st pt.</b> Point on existing vertex</p> <p>Select the vertex marked with yellow:</p>	
<p><b>2nd pt.</b> Point on edge with proportions</p> <p>Select the edge point marked with yellow (Proportion value is about <b>70%</b>):</p>	

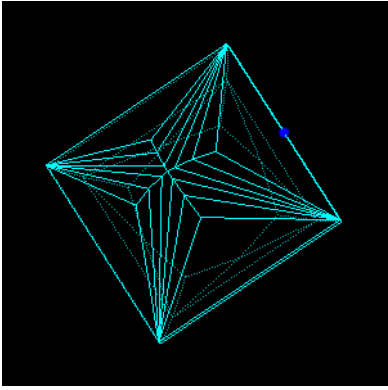
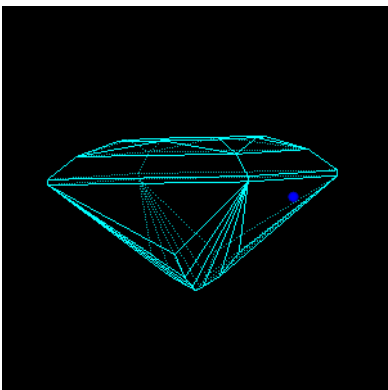

	Facets are ready.	
9	<p>Z-coordinate fixing:</p> <p>Return to the 1st step (Mains, 4 facets) and change Z-coordinate of First constraint point to <b>-0.65</b>.</p> <p>Return to the 5th step (Mains, 4 facets) and change Z-coordinate of First constraint point to <b>-0.50</b>.</p>	

The cut is ready.



## 6.6 Creating Gabrielle cut. Variant 1

### General settings

Edit Symmetry Settings:

Degree of radial symmetry: **8**

Gear notch quantity: **96**

Mirror symmetry: **YES**

Edit Preform Settings:

X dimension: **1**



Y dimension: **1**

Z dimension: **4**

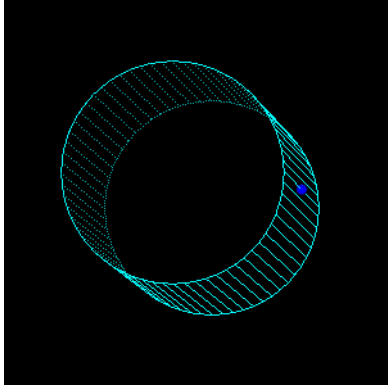
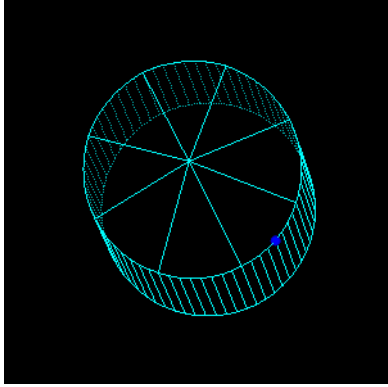
### Cutting Steps



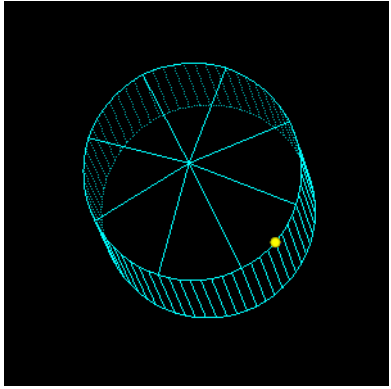
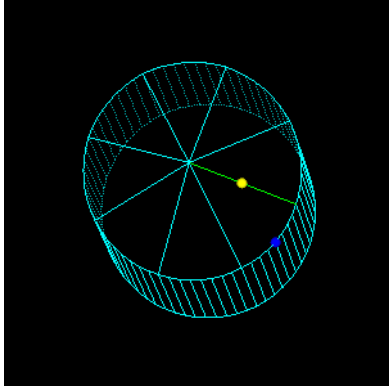
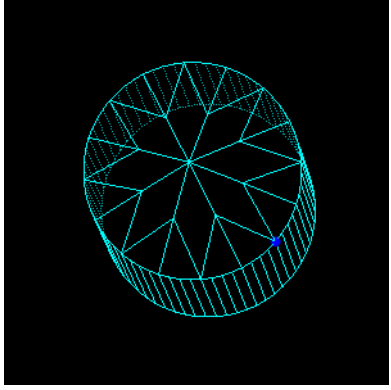

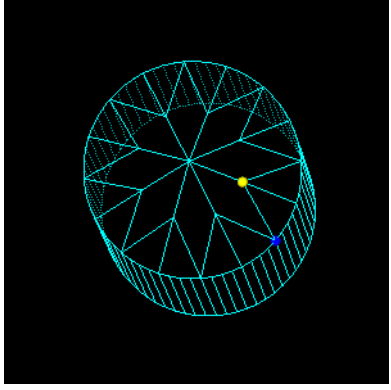

Step	Result
<p>1</p> <p><input type="text" value="Girdle"/></p> <p>Gear index: <b>1</b></p> <p>Degree of radial symmetry: <b>32</b></p>	
<p>2</p> <p><input type="text" value="⊕"/> + Mains</p> <ul style="list-style-type: none"> <li>• Gear index: <b>0</b></li> <li>• Angle: <b>41</b></li> <li>• Degree of radial symmetry: <b>8</b></li> </ul>	



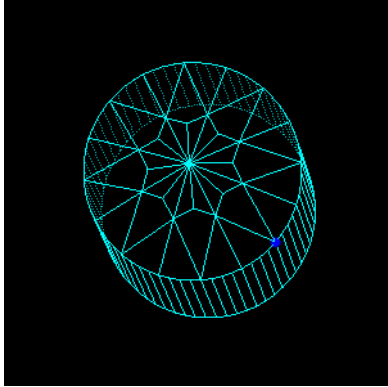

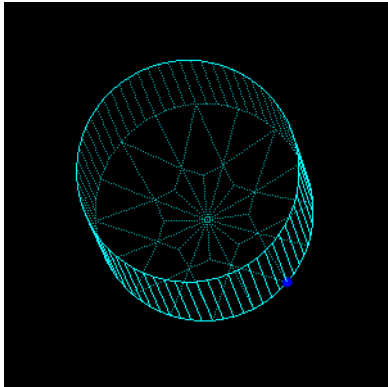
3	 + Facet through two points Gear index: <b>3</b> Degree of radial symmetry: <b>8</b> Use symmetry: <b>YES</b> 1st pt. Point on existing vertex Select the vertex marked with yellow:	
	<b>2nd pt.</b> Point on edge with proportions.  Select the edge point marked with yellow (Proportion value is about <b>50%</b> ):	
	Facets are ready.	
4	 + Facet through one point Gear index: <b>2</b> Angle: <b>33</b> Degree of radial symmetry: <b>8</b> Use symmetry: <b>YES</b> Point on existing vertex  Select the vertex marked with yellow:	

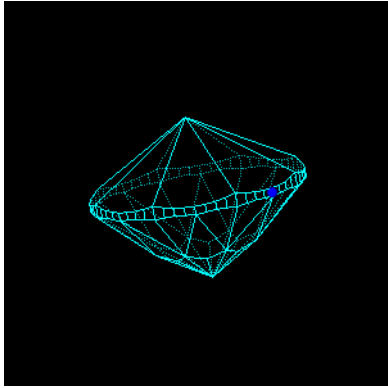

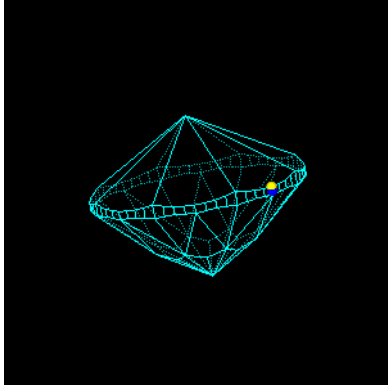

	Facets are ready.	
5		
6	 + Mains Gear index: <b>0</b> Angle: <b>33</b> Degree of radial symmetry: <b>8</b>	
7	 + Facet through two points Gear index: <b>3</b> Degree of radial symmetry: <b>8</b> Use symmetry: <b>YES</b> <b>1st pt.</b> Point on existing vertex Select the vertex marked with yellow:	

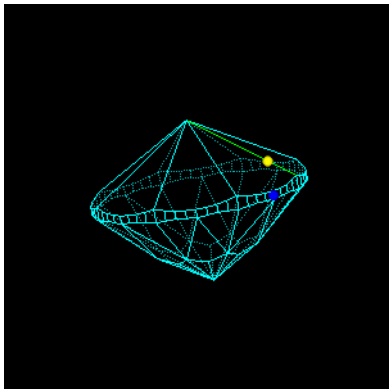
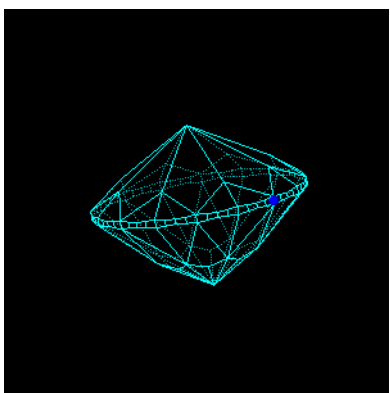

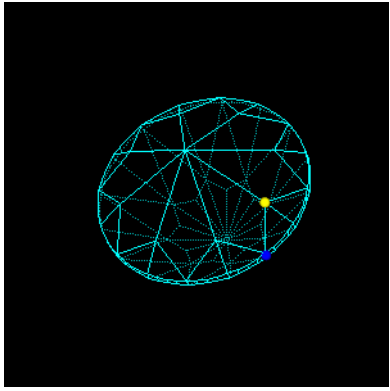
	<p><b>2nd pt.</b> Point on edge with proportions</p> <p>Select the edge point marked with yellow (Proportion value is about <b>25%</b>):</p>	
	<p>Facets are ready.</p>	
8	<p> + Facet through one point</p> <p>Gear index: <b>0</b></p> <p>Angle: <b>25</b></p> <p>Degree of radial symmetry: <b>8</b></p> <p>Use symmetry: <b>YES</b></p> <p>Point on existing vertex</p> <p>Select the vertex marked with yellow:</p>	







	<p>Facets are ready.</p>	
9	<p> + Facet through one point  Gear index: <b>6</b>  Angle: <b>16</b>  Degree of radial symmetry: <b>8</b>  Use symmetry: <b>YES</b>  Point on existing vertex  Select the vertex marked with yellow:</p>	
	<p>Facets are ready.</p>	
10	<p> + Point on existing vertex  Select the vertex marked with yellow:</p>	

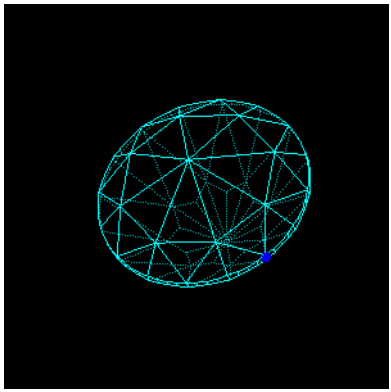

	Table is ready.	 A 3D wireframe model of a sphere, rendered in cyan lines on a black background. A small blue dot is visible on the surface of the sphere.
11	Return to the 2nd step (Mains, 8 facets) and change Z-coordinate of First constraint point to <b>0.05</b>	 A 3D wireframe model of a sphere, rendered in cyan lines on a black background. The sphere is flattened along the Z-axis. A small blue dot is visible on the surface.

The cut is ready.

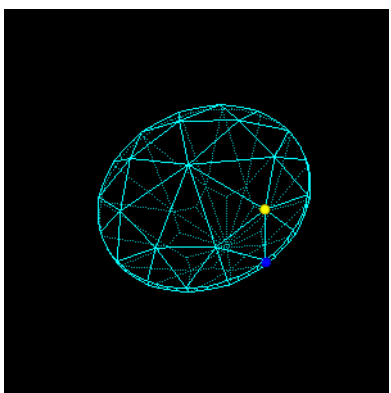
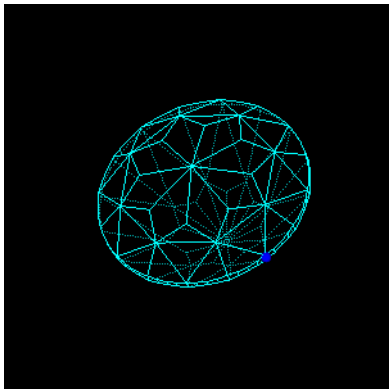

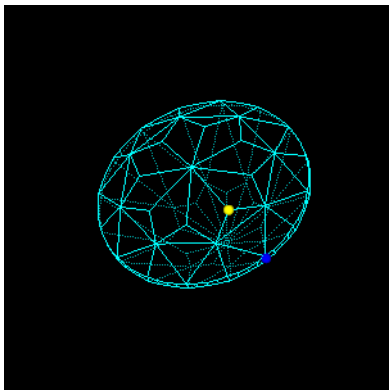
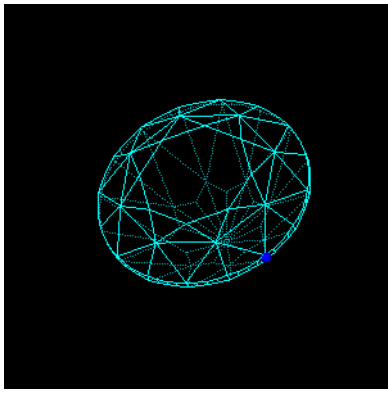
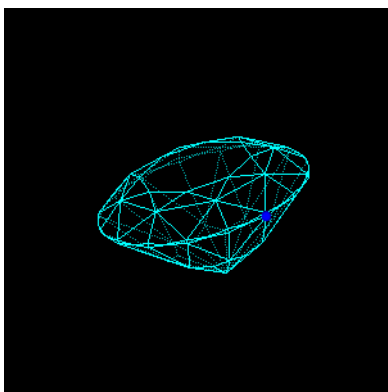
## 6.7 Creating Gabrielle cut through three points. Variant 2

This is new method to create Gabrielle cut - **through three points**. One of the main advantage of this method is you need not to know and set Gear indexes and slope angles while you create layers of facets.

### General settings

Edit Symmetry Settings:

Degree of radial symmetry: **8**

Gear notch quantity: **96**

Mirror symmetry: **YES**



Edit Preform Settings:

X dimension: **1**

Y dimension: **1**

Z dimension: **4**

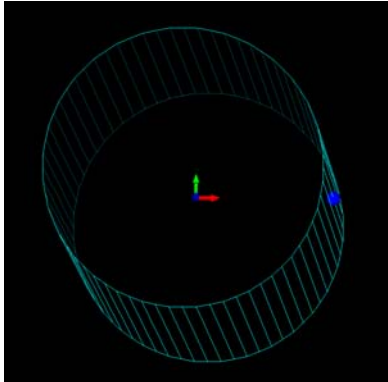
### Cutting Steps

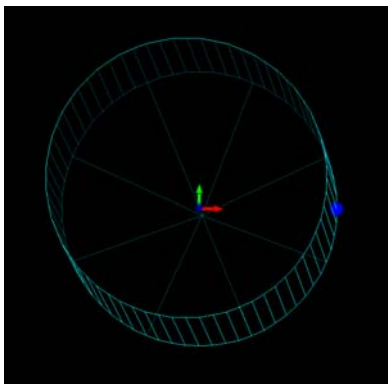
Step	Result
<p>1</p> <p> Girdle</p> <p>Gear index: <b>1</b></p> <p>Degree of radial symmetry: <b>32</b></p>	
<p>2</p> <p> + Mains</p> <ul style="list-style-type: none"> <li>• Gear index: <b>0</b></li> <li>• Angle: <b>41</b></li> <li>• Degree of radial symmetry: <b>8</b></li> </ul>	



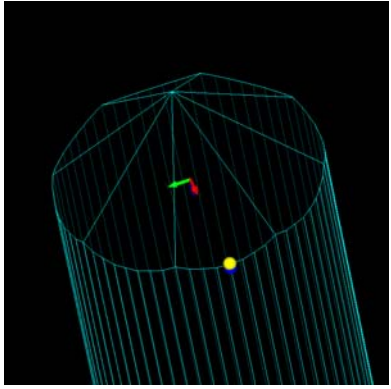
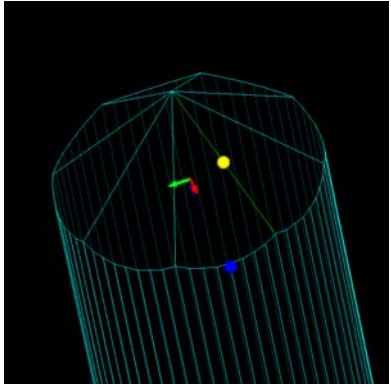
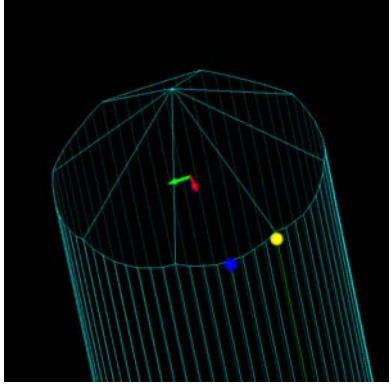
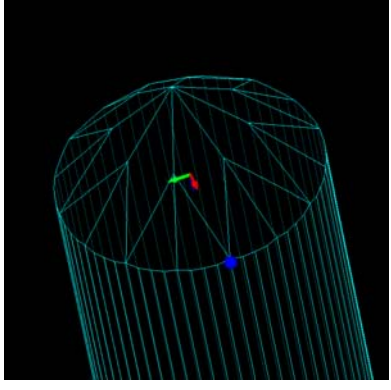

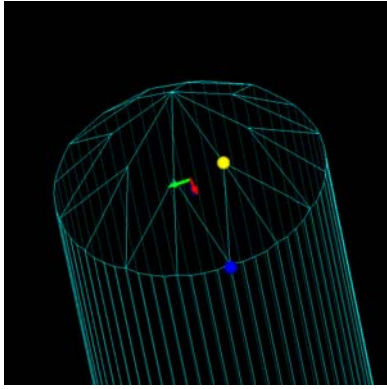
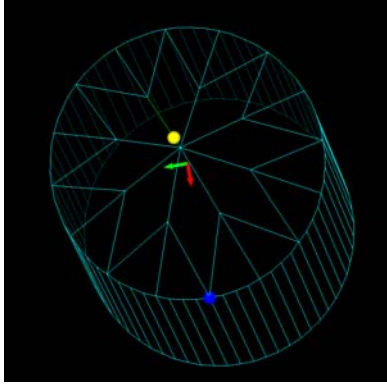
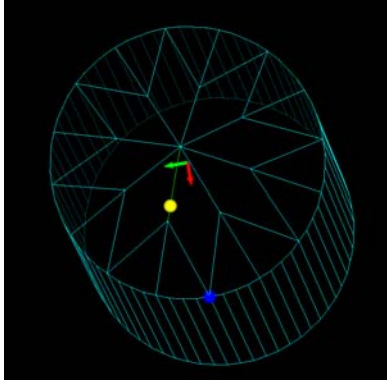
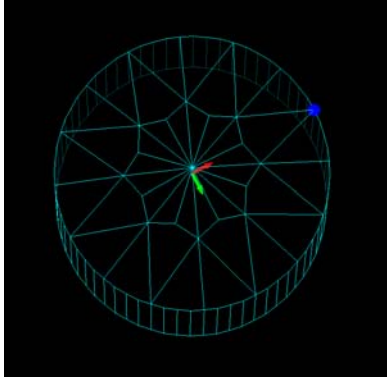

<p>3</p>	<p> + <b>Facet through three points new</b></p> <p>Degree of radial symmetry: <b>8</b></p> <p>Use symmetry: <b>YES</b></p> <p>Mirror symmetry: <b>YES</b></p> <p><b>1st pt.</b> Point on existing vertex</p> <p>Select the vertex marked with yellow:</p>	
	<p><b>2nd pt.</b> Point on edge with proportions.</p> <p>Select the edge point marked with yellow (Proportion value is about <b>50%</b>):</p>	
	<p><b>3rd pt.</b> Point on edge with proportions.</p> <p>Select the edge point marked with yellow (Proportion value is about <b>98%</b>):</p>	
	<p>Facets are ready.</p>	



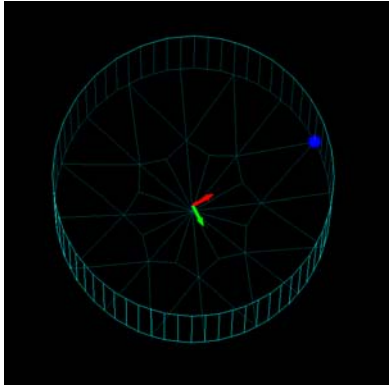

4	<div data-bbox="272 280 408 331" data-label="Image"> </div> <div data-bbox="416 302 911 340" data-label="Text"> <p>+ <b>Facet through three points new</b></p> </div> <p>Degree of radial symmetry: <b>8</b></p> <p>Use symmetry: <b>YES</b></p> <p>Mirror symmetry: <b>YES</b></p> <p><b>1st pt.</b> Point on existing vertex</p> <p>Select the vertex marked with yellow:</p>	
	<p><b>2nd pt.</b> Point on edge with proportions.</p> <p>Select the edge point marked with yellow (Proportion value is about <b>80%</b>):</p>	
	<p><b>3rd pt.</b> Point on edge with proportions.</p> <p>Select the edge point marked with yellow (Proportion value is about <b>20%</b>):</p>	
	<p>Facets are ready.</p>	

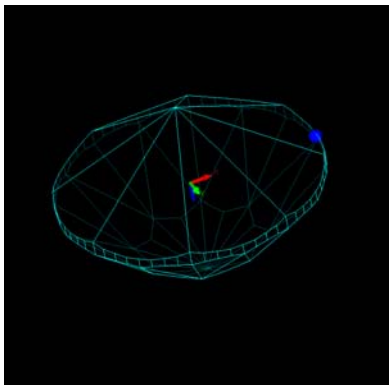

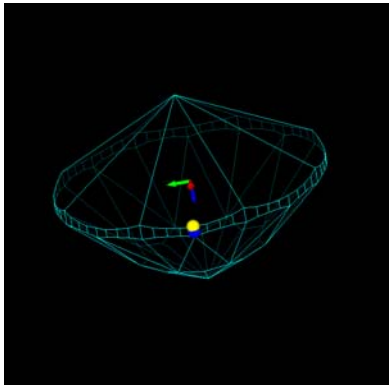
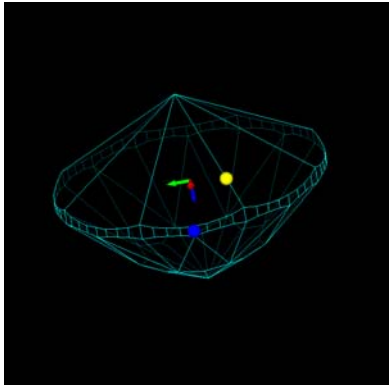

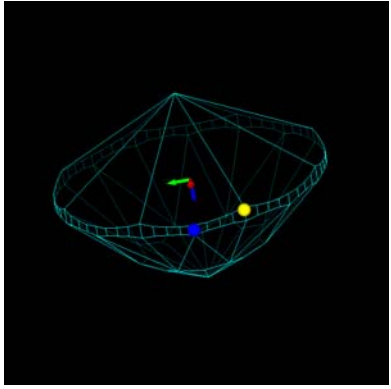
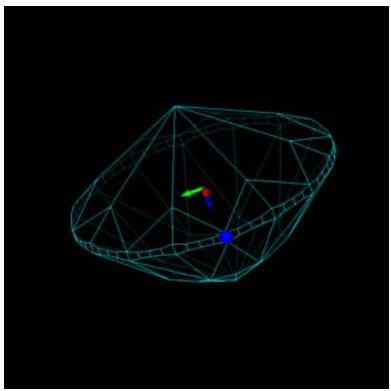

5		
6	 + Mains Gear index: <b>0</b> Angle: <b>33</b> Degree of radial symmetry: <b>8</b>	
7	 + <b>Facet through three points new</b> Degree of radial symmetry: <b>8</b> Use symmetry: <b>YES</b> Mirror symmetry: <b>YES</b> <b>1st pt.</b> Point on existing vertex  Select the vertex marked with yellow:	
	<b>2nd pt.</b> Point on edge with proportions  Select the edge point marked with yellow (Proportion value is about <b>25%</b> ):	

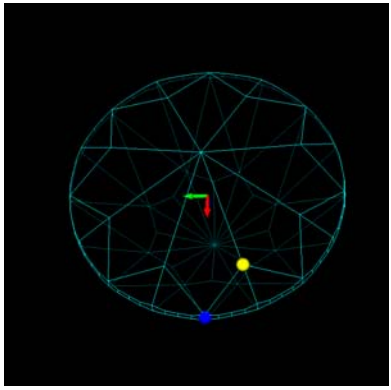
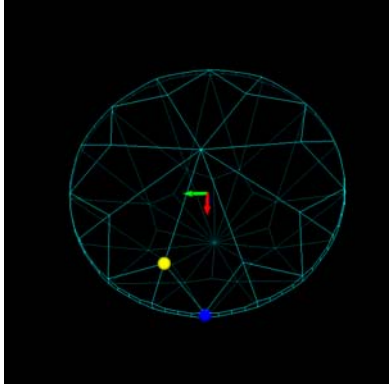

	<p><b>3rd pt.</b> Point on edge with proportions.</p> <p>Select the edge point marked with yellow (Proportion value is about <b>75%</b>):</p>	
	<p>Facets are ready.</p>	
8	<p> + <b>Facet through three points new</b></p> <p>Degree of radial symmetry: <b>8</b></p> <p>Use symmetry: <b>YES</b></p> <p>Mirror symmetry: <b>YES</b></p> <p><b>1st pt.</b> Point on existing vertex</p> <p>Select the vertex marked with yellow:</p>	
	<p><b>2nd pt.</b> Point on edge with proportions</p> <p>Select the edge point marked with yellow (Proportion value is about <b>25%</b>):</p>	

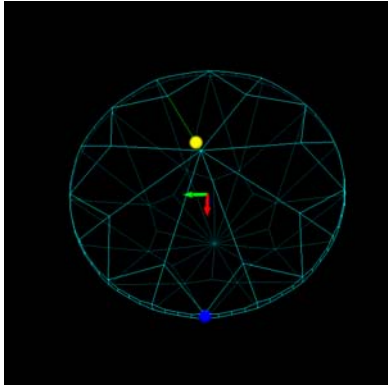
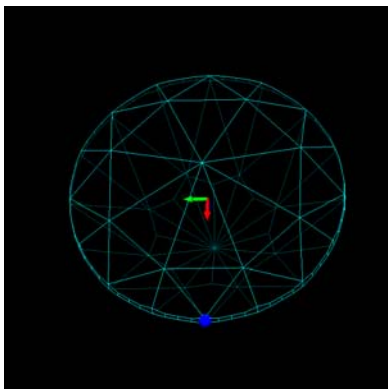

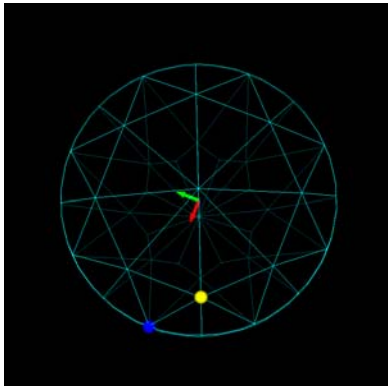
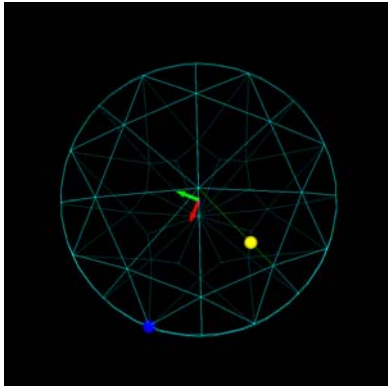
	<p><b>3rd pt.</b> Point on edge with proportions.</p> <p>Select the edge point marked with yellow (Proportion value is about <b>85%</b>):</p>	
	<p>Facets are ready.</p>	
9	<p> ++ <b>Facet through three points new</b></p> <p>Degree of radial symmetry: <b>8</b></p> <p>Use symmetry: <b>YES</b></p> <p>Mirror symmetry: <b>NO</b></p> <p><b>1st pt.</b> Point on existing vertex</p> <p>Select the vertex marked with yellow:</p>	
	<p><b>2nd pt.</b> Point on edge with proportions</p> <p>Select the edge point marked with yellow (Proportion value is about <b>40%</b>):</p>	

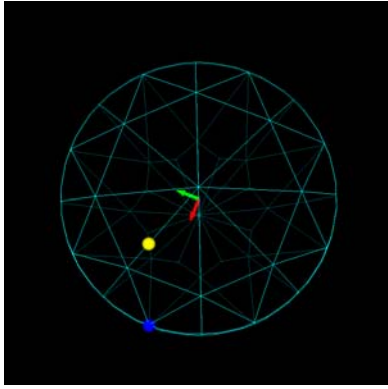
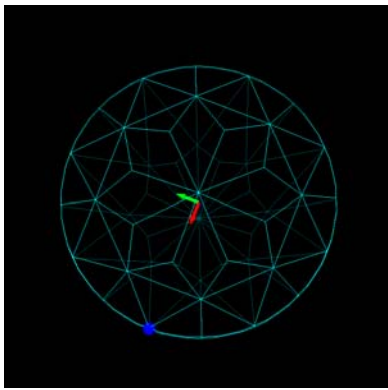
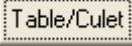
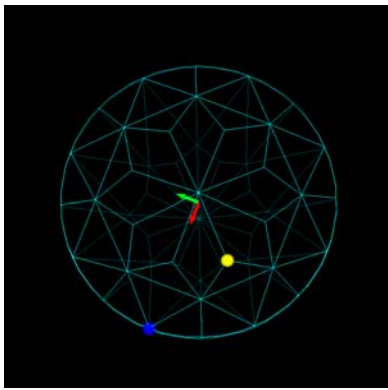
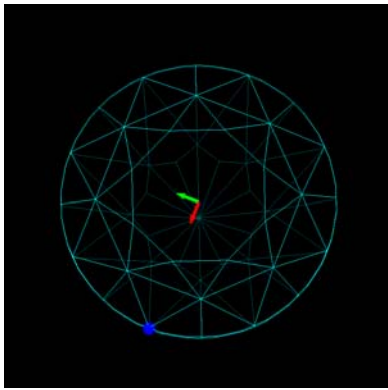

	<p><b>3rd pt.</b> Point on edge with proportions.</p> <p>Select the edge point marked with yellow (Proportion value is about <b>40%</b>):</p>	
	<p>Facets are ready.</p>	
<p>10</p>	<p> + Point on existing vertex</p> <p>Select the vertex marked with yellow:</p>	
	<p>Table is ready.</p>	

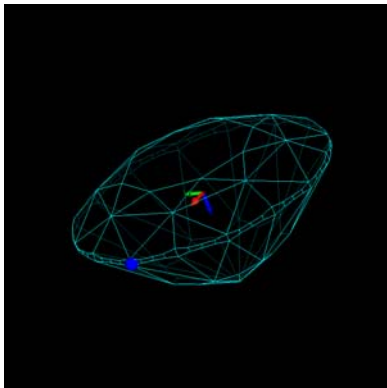

11	Return to the 2nd step (Mains, 8 facets) and change Z-coordinate of First constraint point to <b>-0.05</b>	
----	--	---

The cut is ready.

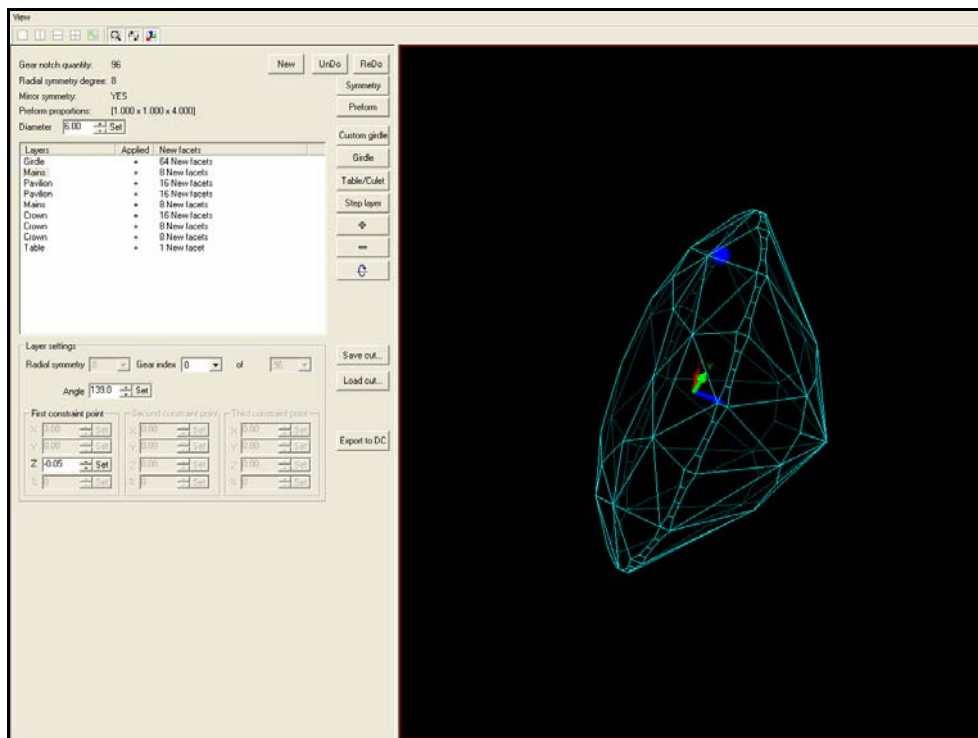

The screenshot shows a software interface with a 3D wireframe model of a dome-like structure on the right. The left panel contains various settings and a table of layers.

**Settings:**

- Gear notch quantity: 96
- Radial symmetry degree: 0
- Mirror symmetry: YES
- Perform operations: [1.000 × 1.000 × 4.000]
- Diameter: 8.00 [Set]

**Layers Table:**

Layers	Applied	New facets
Gicle	+ 64	New facets
Mains	+ 8	New facets
Pavilion	+ 16	New facets
Pavilion	+ 16	New facets
Mains	+ 8	New facets
Down	+ 16	New facets
Down	+ 8	New facets
Crown	+ 8	New facets
Table	+ 1	New facet

**Layer settings:**

- Radial symmetry: [ ] of [ 30 ]
- Angle: 139.0 [Set]

**Constraint points:**

First constraint point	Second constraint point	Third constraint point
X: 1.00 [Set]	X: 1.00 [Set]	X: 1.00 [Set]
Y: 1.00 [Set]	Y: 1.00 [Set]	Y: 1.00 [Set]
Z: -0.05 [Set]	Z: 1.00 [Set]	Z: 1.00 [Set]

**Buttons:** New, Undo, Redo, Symmetry, Perform, Custom grids, Grids, Table/Culet, Stop layer, Save out..., Load out..., Export to DC.

## 6.8 Creating Emerald cut

### General settings

Edit Symmetry Settings:

Degree of radial symmetry: **2**

Gear notch quantity: **96**

Mirror symmetry: **YES**

Edit Preform Settings:

X dimension: **1.5**

Y dimension: **1**

Z dimension: **4**

### Cutting Steps

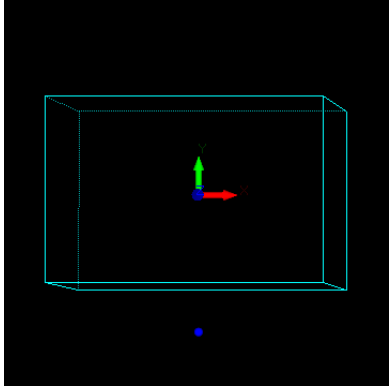
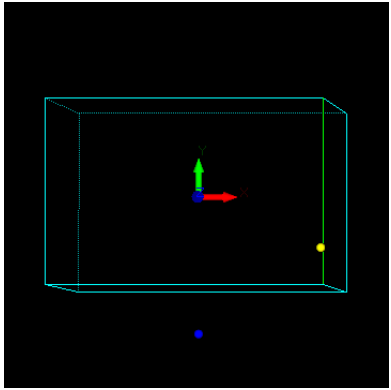
Step	Result
<p>1  + Facet through one point</p> <p>Gear index: <b>16</b></p> <p>Angle: <b>90</b></p> <p>Degree of radial symmetry: <b>2</b></p> <ul style="list-style-type: none"> <li>• Use symmetry: <b>YES</b></li> <li>• Point on edge with proportions</li> </ul>	
<p><b>1st pt.</b> Point on edge with proportions.</p> <p>Select the edge point marked with yellow (Proportion value is about <b>80%</b>):</p>	



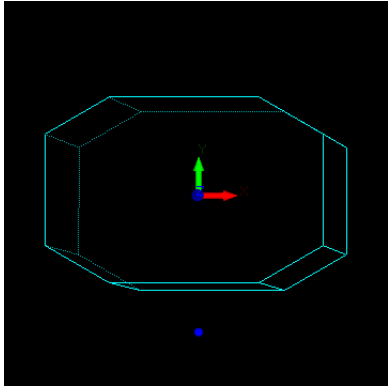
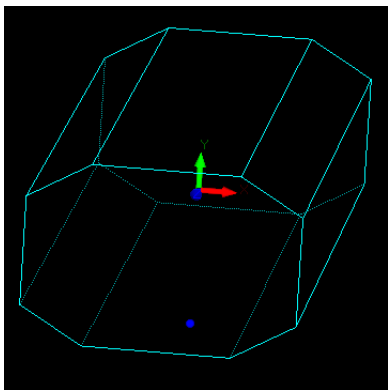
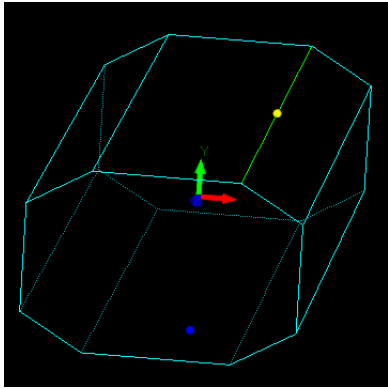
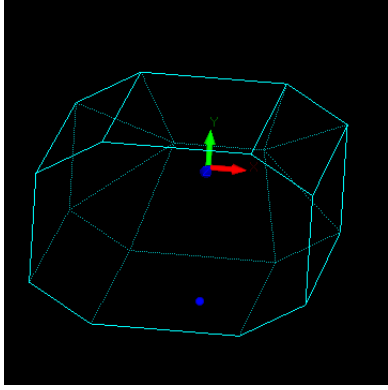



	<p>Facets are ready.</p>	
<p>2</p>	<p><span style="border: 1px solid black; padding: 2px;">Step layer</span></p> <p>Angle: <b>50</b></p> <p>Point on edge with proportions</p>	
	<p><b>1st pt.</b> Point on edge with proportions.</p> <p>Select the edge point marked with yellow (Proportion value is about <b>50%</b>):</p>	
	<p>Facets are ready.</p>	

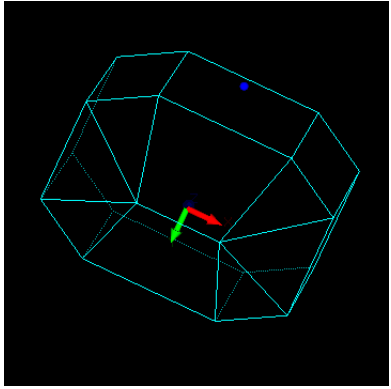
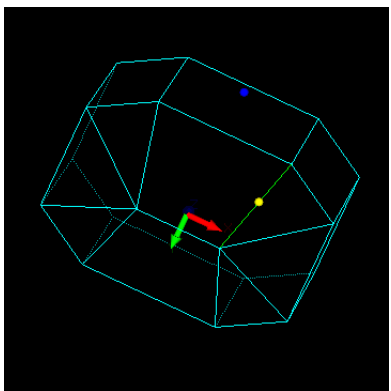
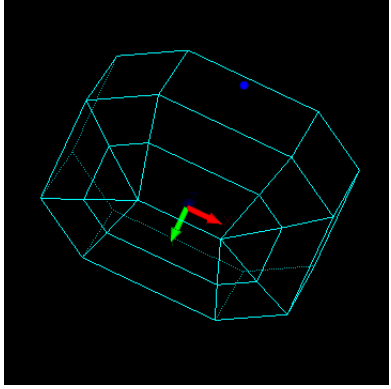
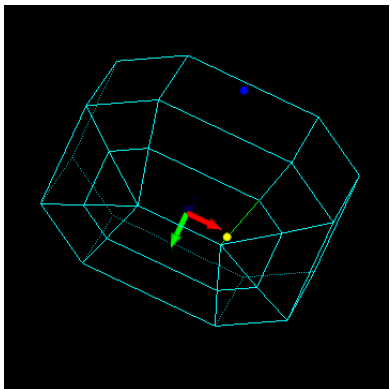

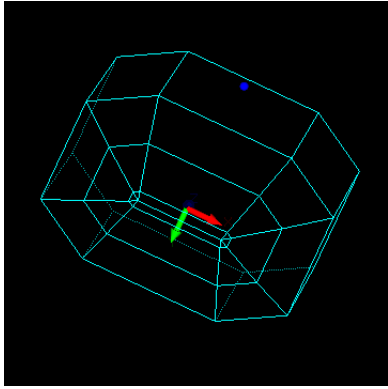

3	<p><b>Step layer</b></p> <p>Angle: <b>41</b></p> <p>Point on edge with proportions</p>	
	<p><b>1st pt.</b> Point on edge with proportions.</p> <p>Select the edge point marked with yellow (Proportion value is about <b>45%</b>):</p>	
	<p>Facets are ready.</p>	
4	<p><b>Step layer</b></p> <p>Angle: <b>36</b></p> <p>Point on edge with proportions</p> <p><b>1st pt.</b> Point on edge with proportions.</p> <p>Select the edge point marked with yellow (Proportion value is about <b>83%</b>):</p>	

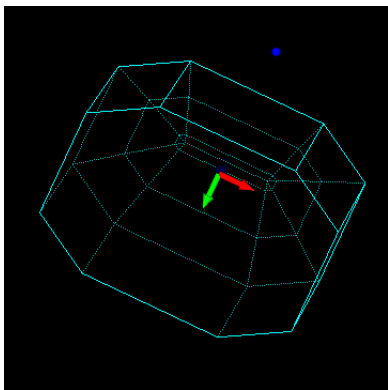

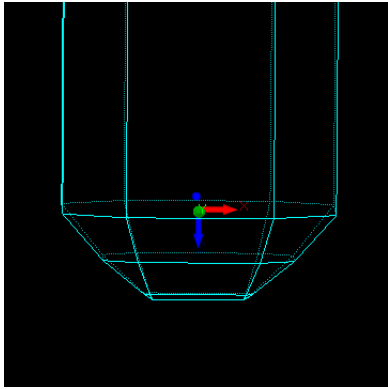
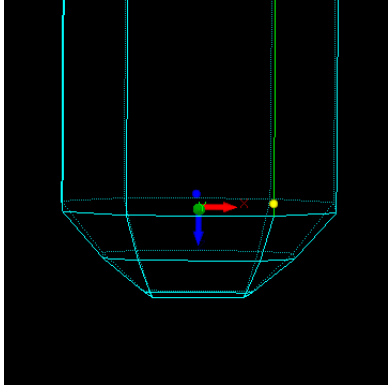
	<p>Facets are ready.</p>	
<p>5</p>		
<p>6</p>	 <p>Angle: <b>40</b> Point on edge with proportions</p>	
	<p><b>1st pt.</b> Point on edge with proportions.  Select the edge point marked with yellow (Proportion value is about <b>3%</b>):</p>	

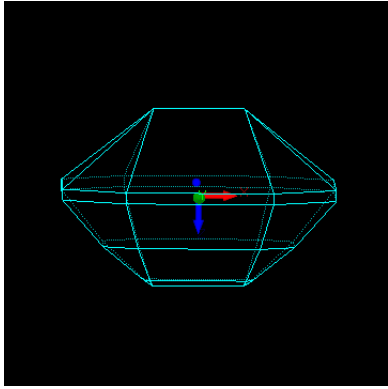
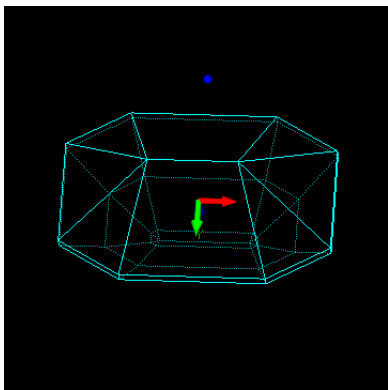
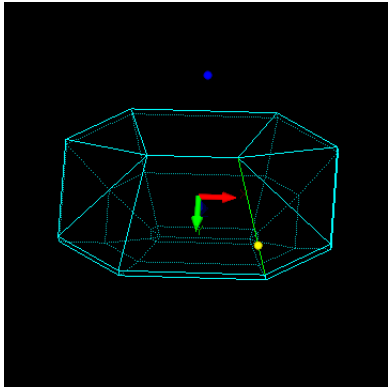
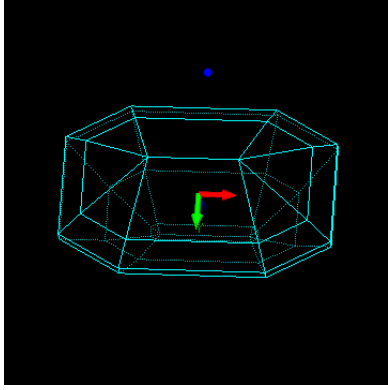

	<p>Facets are ready.</p>	
<p>7</p>	<p><b>Step layer</b></p> <p>Angle: <b>35</b></p> <p>Point on edge with proportions</p>	
	<p><b>1st pt.</b> Point on edge with proportions.</p> <p>Select the edge point marked with yellow (Proportion value is about <b>25%</b>):</p>	
	<p>Facets are ready.</p>	

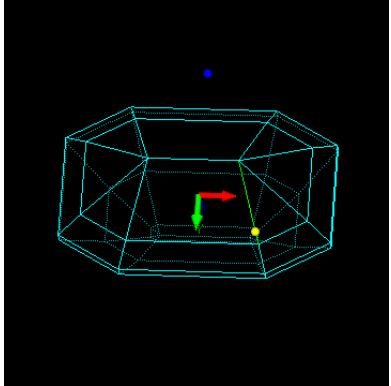
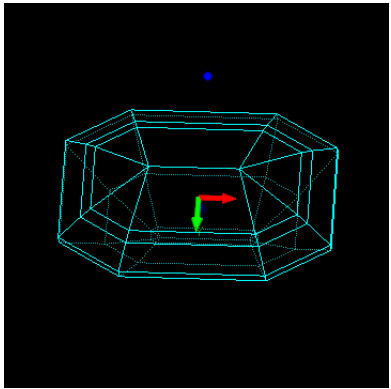
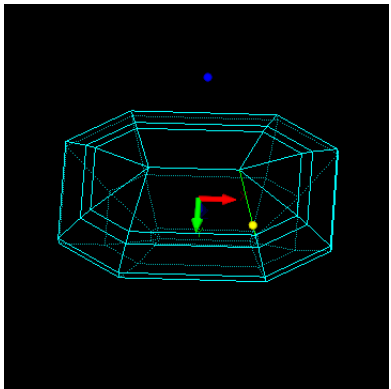

8	<p><b>Step layer</b></p> <p>Angle: <b>26</b></p> <p>Point on edge with proportions</p> <hr/> <p><b>1st pt.</b> Point on edge with proportions.</p> <p>Select the edge point marked with yellow (Proportion value is about <b>15%</b>):</p> <hr/> <p>Facets are ready.</p>	  
9	<p><b>Table/Culet</b> + Point on edge with proportions</p> <p>Select the edge point marked with yellow:</p>	

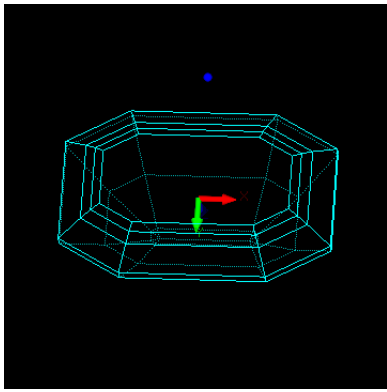

	<p>Table is ready.</p>	 A 3D wireframe model of a table, rendered in cyan lines against a black background. The table has a rectangular top and four legs. A small blue dot is positioned above the center of the table. A red arrow points to the right, and a green arrow points downwards, both originating from the center of the table's top surface, indicating a cut or a specific point of interest.
--	------------------------	--

The cut is ready.

## 6.9 Save cut, load cut and export to DC

Cut Designer allows to save, load and export to DC created cuts.

To save cut in XML format press button Save cut..

To open cut in XML format press button Load cut..

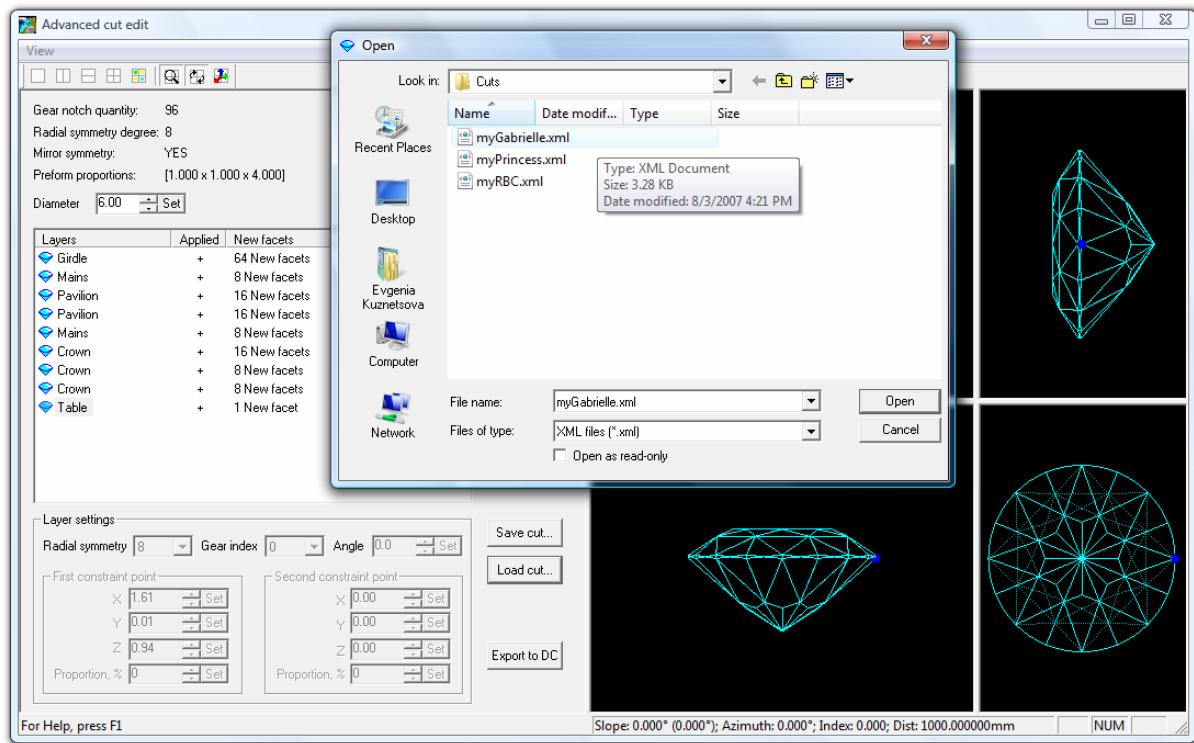

To export cut to DiamCalc:

- Press button Export to DC
- Type a name for new cut and press Ok



## Explore your cut in DiamCalc main window

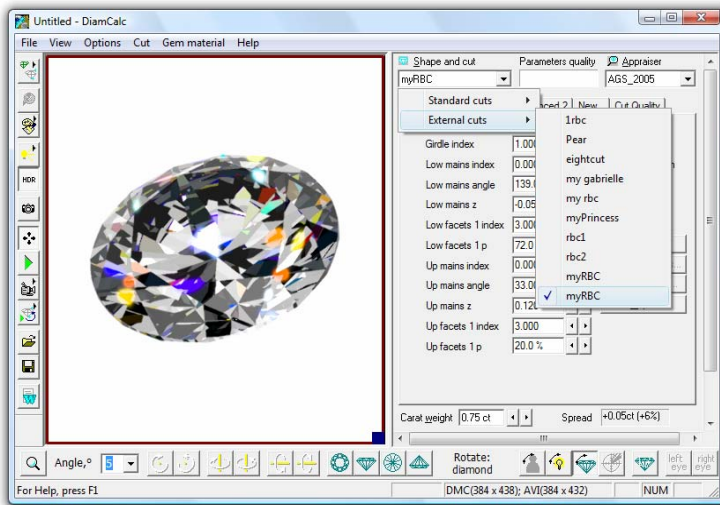

## Find your cut in the external cut list

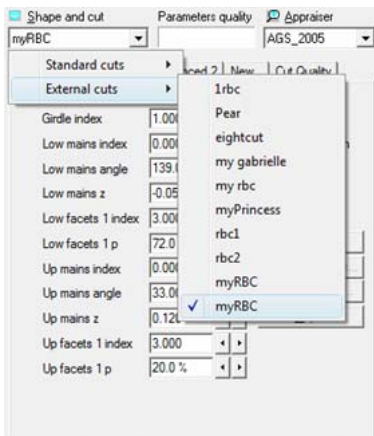

If you need to get additional information about cuts open panel **Parametric cuts info** from menu **Cut / Parametric cuts info**. See Visible cut name, Cut name for appraiser, ID and Module name.

Visible cut name	Cut name for appraiser	ID	Module name
Heart	Heart	{C3A527D4-1198-4CEF-8D65-824429DDCF8C}	DiamCalc.exe
Marquise	Marquise	{FE68C6ED-1C29-11D4-8C66-00105A711E33}	DiamCalc.exe
Oval	Oval	{FE68C6EE-1C29-11D4-8C66-00105A711E33}	DiamCalc.exe
Pear	Pear	{FE68C6EF-1C29-11D4-8C66-00105A711E33}	DiamCalc.exe
Princess 2-chevron	Prince	{FE68C6F0-1C29-11D4-8C66-00105A711E33}	DiamCalc.exe
Princess 3-chevron	Princess 3s	{7E9CA5C6-ACCD-4851-839A-2BA1AB105C78}	DiamCalc.exe
Prism	Prism	{0984E6B1-FA0A-4DCD-9B0F-26342A574E60}	DiamCalc.exe
Radiant	Radiant	{6C2C8945-8300-433E-A197-E139E94E5BCE}	DiamCalc.exe
Marquise_wBT.P...	Marquise_wBT.P24C32	{B128D821-71B9-46C8-A6FE-C6E6D19E00D2}	MarquiseWBT_P24C...
MoonMarquise.P...	MoonMarquise.P34C32	{06C6CD36-2318-4E24-BB85-42A18B08E444}	MoonMarquise_P34...
MoonMarquise.P...	MoonMarquise.P36C32	{8DA4B5F6-9EBB-4BD2-9FA8-98F413E0B333}	MoonMarquise_P36...
MoonMarquise_...	MoonMarquise_wBT.P...	{EA78E79E-20E2-47F6-89C1-47CF243999E6}	MoonMarquiseWBT...
MoonMarquise_...	MoonMarquise_wBT.P...	{EF87513E-4808-41AF-815A-362DA2950272}	MoonMarquiseWBT...
MoonOval.P36C32	MoonOval.P36C32	{F1E2BCCA-181F-45DC-B8A2-4E88A9D4D962}	MoonOval_P36C32.dll
MoonOval_wBT...	MoonOval_wBT.P36C32	{41644482-C736-4E9B-9489-36E27E1D0663}	MoonOvalWBT_P36...
MoonPear_wBT...	MoonPear_wBT.P32C32	{15D55151-28DA-4782-9EC1-E2903F2464DF}	MoonPearWBT_P32...
MoonPear_wBT...	MoonPear_wBT.P36C32	{B868970A-4790-47C8-94EC-7397D95A4E10}	MoonPearWBT_P36...
MoonPear_wBT...	MoonPear_wBT.P36C32	{465FADDC-6A40-485C-984F-857C9C58C8E0}	MoonPearWBT_P36...
Octagon-Emerald.P32...	Octagon-Emerald.P32...	{F091487A-9FDF-4E8C-AB6E-61E455A76DF9}	OctagonEmerald_P...
Octagon.P32C24	Octagon.P32C24	{B300D832-4AA8-4402-B587-89D6744526FA}	Octagon_P32C24.dll
Oval_wBT.P24C32	Oval_wBT.P24C32	{CD9C9B98-82D0-4583-86CE-53E912233536}	OvalWBT_P24C32.dll
Pear	Pear	{FE68C6E2-1C29-11D4-8C66-00105A711E33}	Pear.dll
Pear_wBT.P24C32	Pear_wBT.P24C32	{C3C1A347-D4B9-490C-A469-7852D53919FE}	PearWBT_P24C32.dll
Radiant.P28C24	Radiant.P28C24	{C2E71C02-3CEB-4E4A-9F99-0AE0D4F3C184}	Radiant_P28C24.dll
myPrincess	myPrincess	{EE94B57C-564F-4538-8C12-9905722BD20E}	GingemaUser.dll



## 6.10 Creating custom girdle

This feature allows creating various shapes of girdle for user choice.  
To create custom girdle:

- Press button **Custom Girdle**

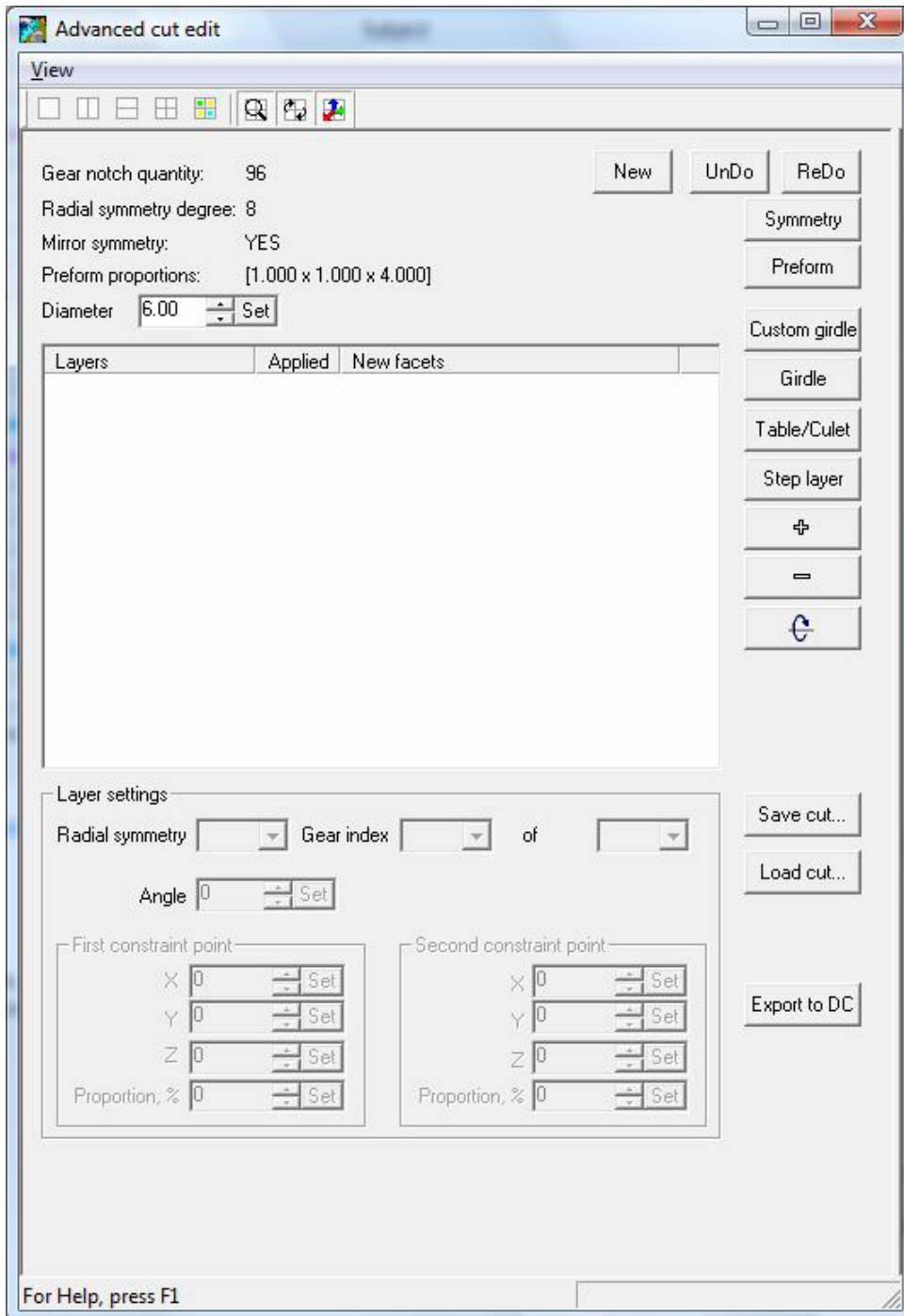

- In case some scanned model is loaded in DC before launching CutDesigner, the dialog window appears:

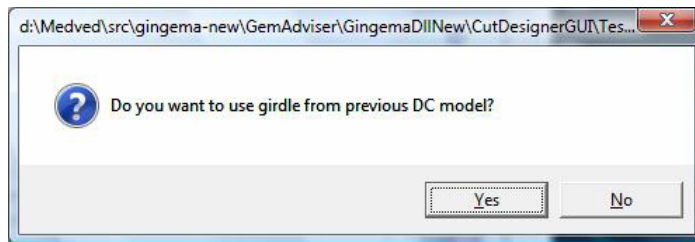

- To use girdle from previous DC model press button **Yes**
- The alert window appears.

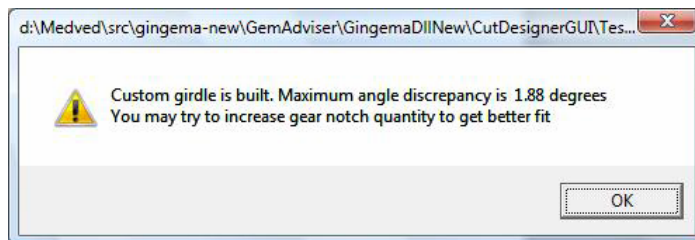

- Press **OK**
- To use some custom girdle from EPS file press button **No**

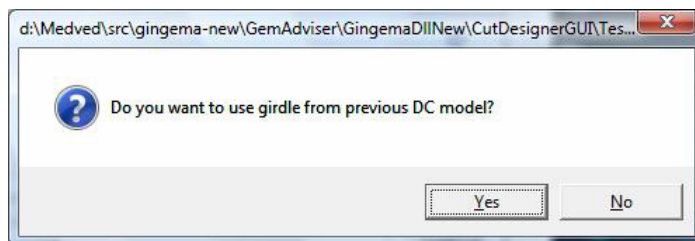

- Select **EPS** file with girdle shape and press button **Open**

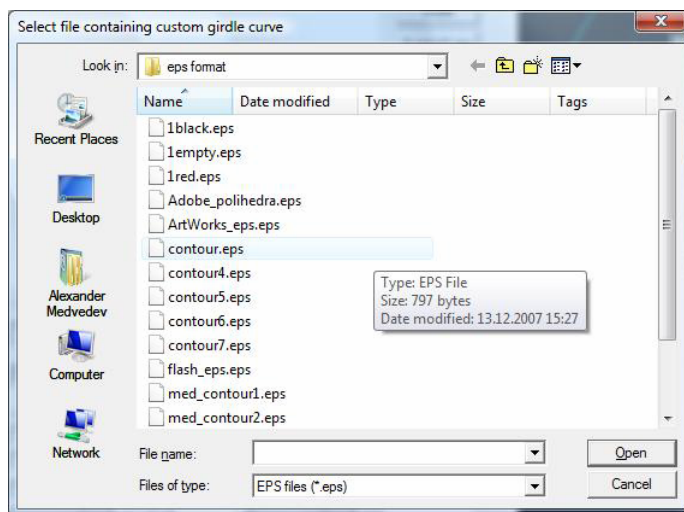

- Press **OK** in the alert window.

- The Girdle shape is ready

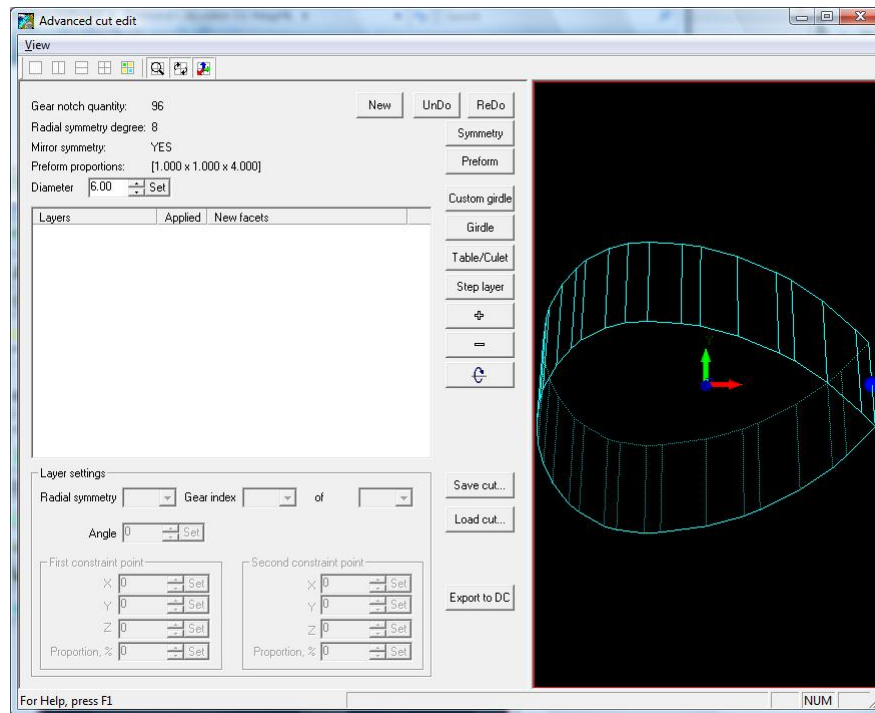

- In case no scanned model is loaded in DC the Select file containing girdle curve window appears:

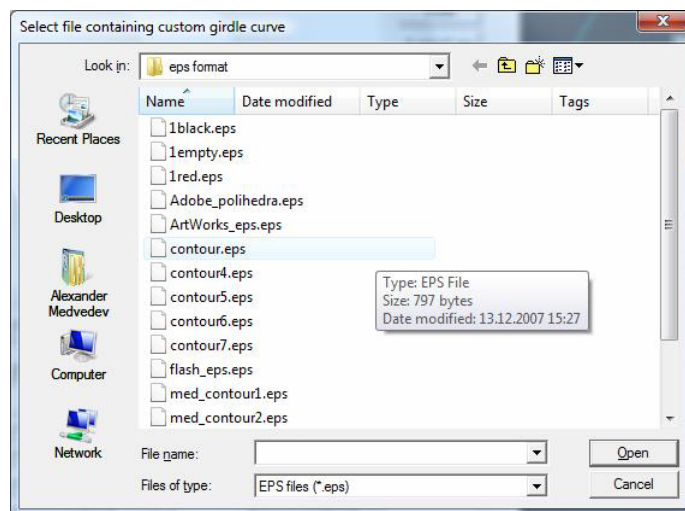

- Select **EPS** file with girdle shape and press button **Open**.

- Press **OK** in the alert window.
- The Girdle shape is ready

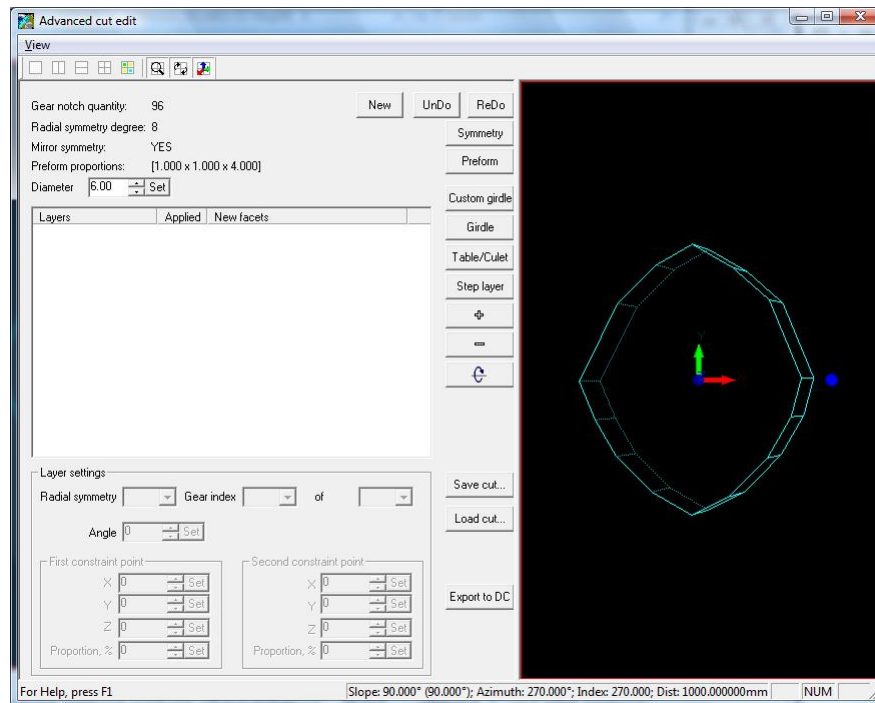



## 6.11 Creating custom girdle shape by third-party software

Xara Extreme software allows to create various shape 2D contours.

### Step 1

Download **Xara Extreme Pro 3.2 - 30 Day Trial** from Xara`s web-site.

<http://www.xara.com/downloads/xtreme/>

Install and run.

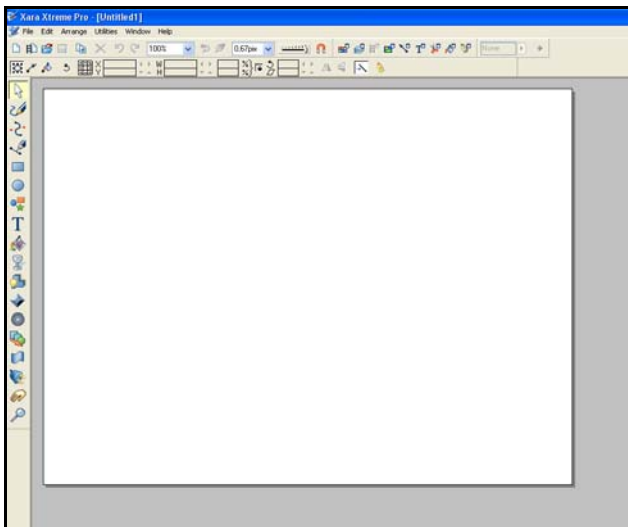

### Step 2

*Grids* help to create contours more precious and easy. To show Grids select from menu **Window / Show Grid**.

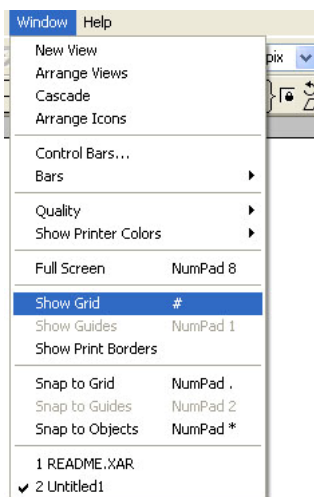

Select Snap to Grid

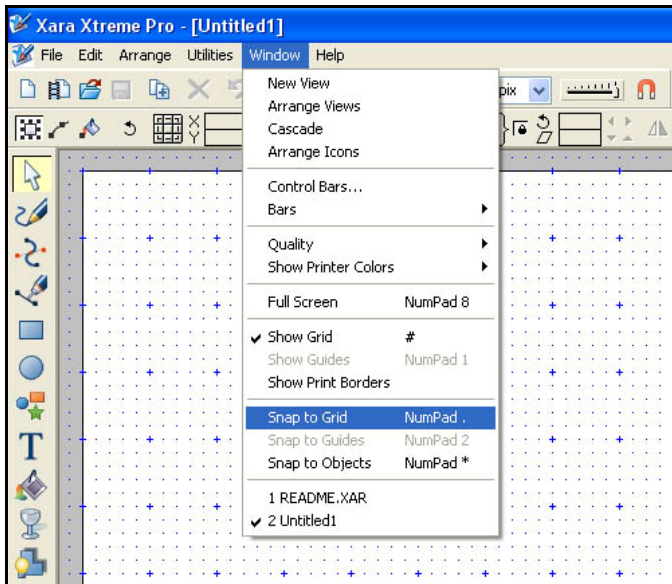

### Step 3

Select **Pen Tool** form the left bar.

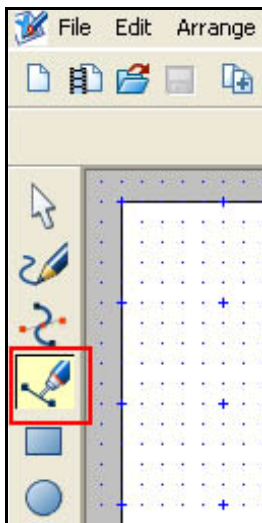



## Create a contour with **Pen Tool**

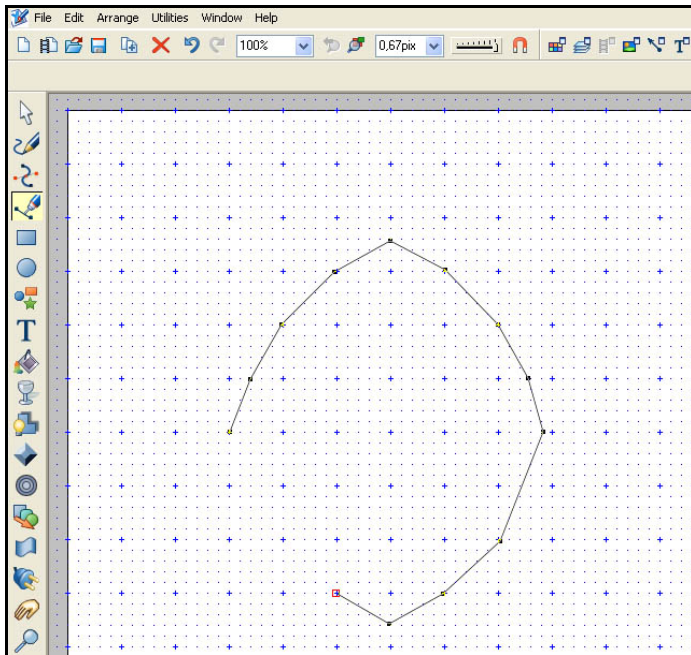

Your contour is ready!

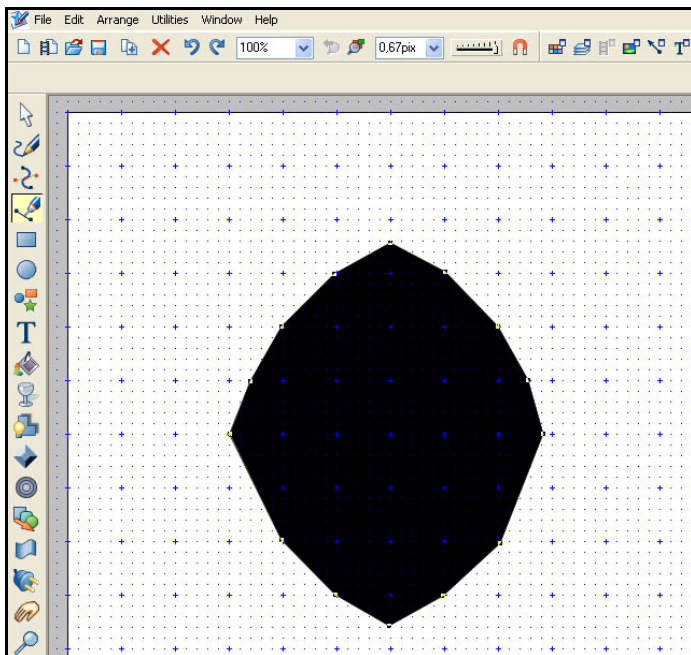



## Step 4

To export your contour into **EPS** file select menu **File / Export...**

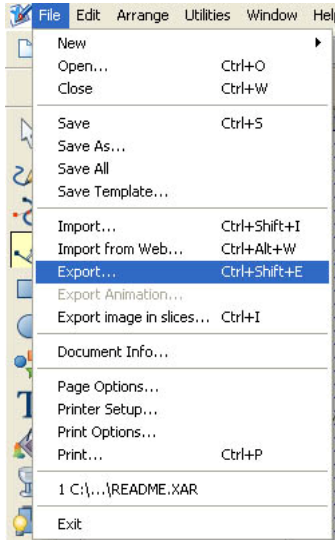

Select type of file **ArtWorks EPS [\* .eps]**.

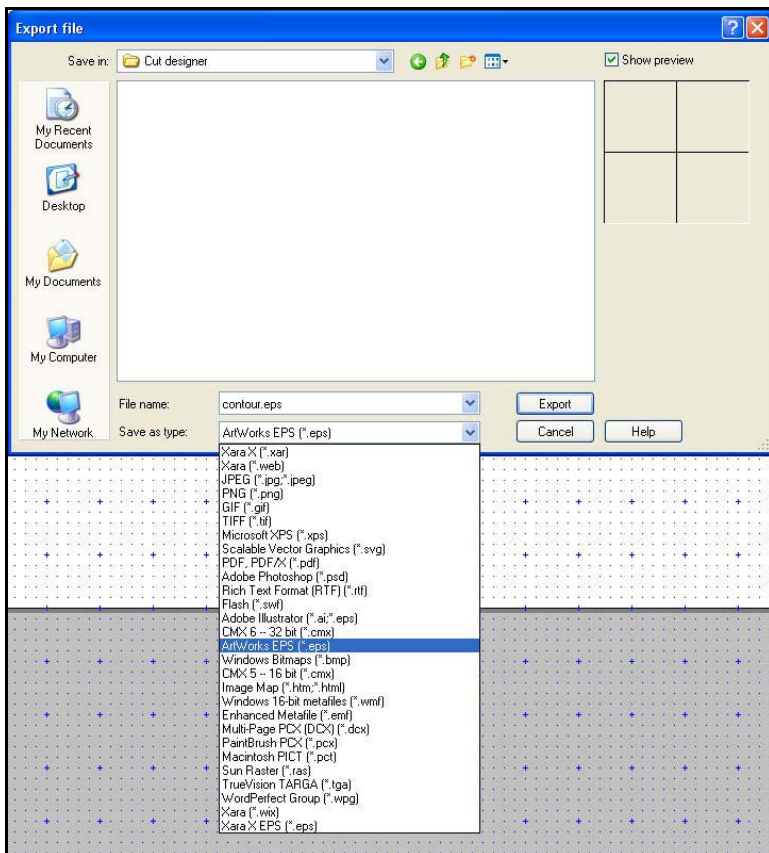

Press **Export** button.

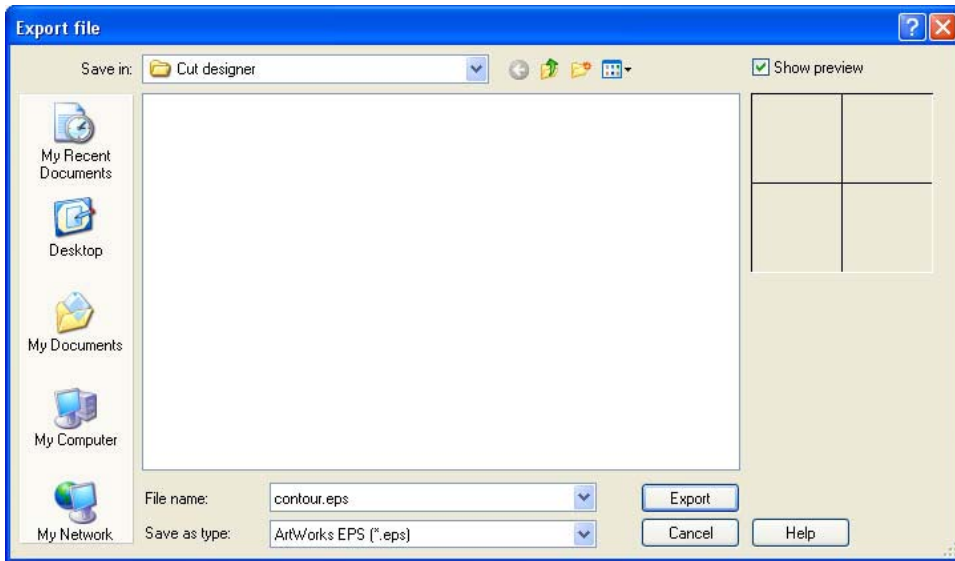

Press **Export** button In the **Xara Xtreme Pro** alert window

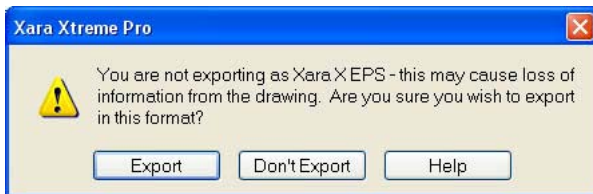

Your file \*.eps with contour is ready. Import it in the Cut Designer.

## 7 Estimating weight of diamonds

DiamCalc allows to estimate weight of the diamonds and other stones by entering known proportions and calculate different cut parameters one from another.

Experts and dealers usually use formulas, tables or calculators to estimate the mass of mounted diamonds. These methods often give approximate results, as they can take into account only a predefined set of parameters. DiamCalc allows to perform calculation making full use of any set of proportions that can be measured in a given case.

A similar problem exists in diamond marking. DiamCalc provides a unique opportunity to estimate parameters of a future diamond as precisely as the available data allows.

To estimate the diamond mass with DiamCalc:

- Choose a cut style in the list **Shape and cut**
- Input the main parameters (e.g. the **Diameter**)
- The stone mass is promptly displayed in the relevant field **Carat weight**

The screenshot displays the 'Shape and cut' tab of the DiamCalc software. The interface includes several input fields and buttons for configuring diamond parameters. The 'Shape and cut' dropdown is set to 'Brilliant'. The 'Parameters quality' field shows '0' and the 'Appraiser' field shows 'AGS\_2005'. The 'Proportions' section is active, showing various parameters with input fields and arrows for adjustment. The 'Carat weight' field at the bottom left displays '0.78 ct' and the 'Spread' field shows '+0.01 ct (+1%)'.

Parameter	Value
Shape and cut	Brilliant
Parameters quality	0
Appraiser	AGS_2005
Diameter	6.00 mm
Sec. diameter	6.00 mm
Total depth	3.63 mm
Crown height (bzl)	14.8 %
Crown angle	34.50 °
Table diameter	57.0 %
Pav. depth(mains)	43.1 %
Pavilion angle(max)	40.75 °
Culet	Pointed
Girdle (valley)	Very Thin
Carat weight	0.78 ct
Spread	+0.01 ct (+1%)

For more accurate weight estimation the other parameters should be specified.  
See how it is done:

- Start DiamCalc and look at the panel with parameters
- All parameters have some values
- Brilliant cut is selected
- Initial diameter of the stone is 6.00 mm (assume this is what we need)
- Now enter all parameters that are known to describe the diamond as precisely as possible

*Note.* To change a parameter, select a value in the corresponding box by the mouse and type in a new value, press key Enter at the end.

For example, set a new value for the Total depth:

- Select a field **Total depth**. The current value of the diamond's total depth is **3.63 mm** (60.6% of the diameter) and the mass is **0.78 ct**. The panel with diamond parameters should look like the following:

The screenshot shows the 'Parameters quality' panel in DiamCalc. The 'Shape and cut' is set to 'Brilliant', 'Parameters quality' is '0', and 'Appraiser' is 'AGS\_2005'. The 'Proportions' tab is active, showing various parameters with input fields and arrows for adjustment. The 'Total depth' is highlighted in blue and set to 3.63 mm. The 'Culet' is set to 'Pointed' and 'Girdle (valley)' is set to 'Very Thin'. The 'Carat weight' is 0.78 ct and the 'Spread' is +0.01 ct (+1%).

Parameter	Value
Diameter	6.00 mm
Sec. diameter	6.00 mm
Total depth	3.63 mm
Crown height (bzl)	14.8 %
Crown angle	34.50 °
Table diameter	57.0 %
Pav. depth(mains)	43.1 %
Pavilion angle(max)	40.75 °
Culet	Pointed
Girdle (valley)	Very Thin
Carat weight	0.78 ct
Spread	+0.01 ct (+1%)

- Type **3.78** to the field **Total depth** to increase Total depth to 3.78 mm (64.4% of the diameter). Press key **Enter**
- The panel with diamond parameters should look like the following:

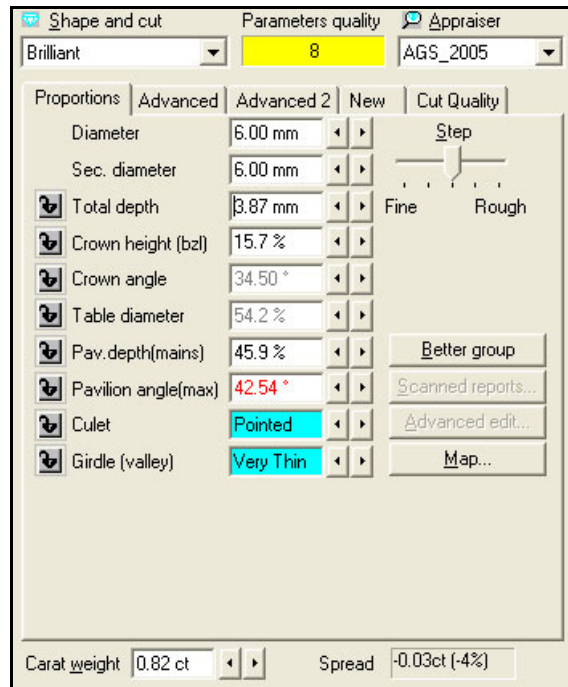

Note, the Diameter remains the same (6 mm), both Crown height and Pavilion depth have increased proportionally to accommodate to a Total height increase, and the mass has been recalculated using a new piece of information: **0.82 ct**.

Other parameters can be changed the same way: select the corresponding value, enter a new one from the keyboard and press key **Enter**.

## 8 Working with cut parameters

### 8.1 Proportion and Advanced tabs

DiamCalc displays cut parameters in a parameter panel, which is located in the right half of the application's window.

A notebook-like structure has three tabs: Proportions, Advanced and Advanced2. Proportions tab holds most common parameters, such as diamond diameter, total height, etc. Most values can be adjusted to describe the stone more precisely. If only some proportions are known, DiamCalc assigns reasonable estimates for parameters that cannot be measured.

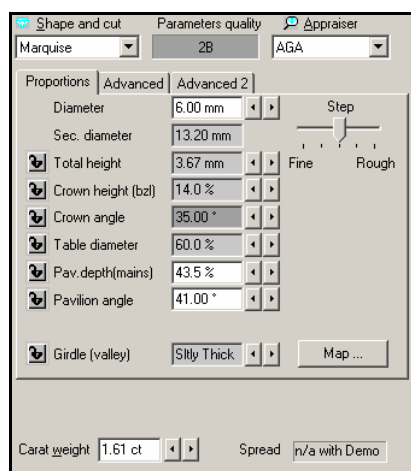

There are two different methods of changing parameter's value. First, a new value can be entered directly from the keyboard. To do this, select a chosen parameter value with the mouse, type in a new value, and press Enter key at the end. The other method is to use buttons that are on the right of each parameter which value can be changed. Note that a slider named Step allows to tune the amount by which those buttons change the value. For example, when the slider is average (default) positions, buttons change the diameter by 0.1 mm; when it is in the Fine position, those same buttons change the diameter by 0.01 mm.

See also «Selecting measurement units and parameters to show» section that describes how to change presentation of some parameters: select one of available measurement units, choose one of similar parameters («dual» parameters), etc.

The parameters on the tab **Advanced** usually depend on the current cut. Examine parameters are available for Brilliant cut diamonds.

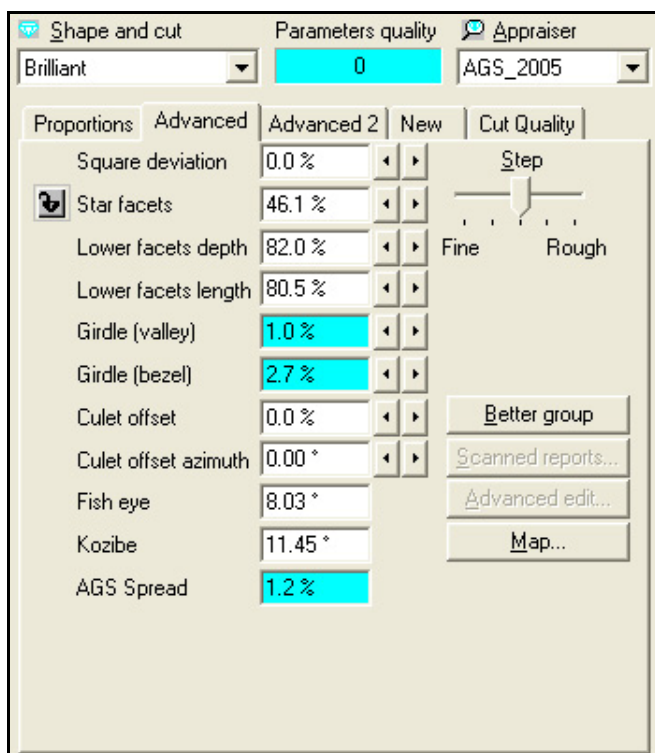

In addition some predefined parameters values (*fixed cuts*) can be used to change the diamond proportion. With the menu **Diamond / Fixed cut** you will be presented with the list of fixed cuts available for the selected diamond shape. For example, if you want to see *Parker* brilliant model you should select **brilliant** shape and then select from menu **Diamond / Fixed cut / Parker**. Fixed cut affects all the cut parameters except the diameter. Fixed cuts are stored in the appraiser data file (see section **Appraising diamonds quality and pricing diamonds**) as a text, so parameter values can be modified and new fixed cuts can be defined as well.

## 8.2 Dual parameters

It is possible to use different presentations for some parameters. For instance, a slightly oval shape of the girdle can be described by two diameters, minimum and maximum. Alternatively, it can be specified by maximum diameter and deviation (brilliant cut) or ratio of maximum and minimum diameters (fancy cuts).

To choose a presentation option of such a parameter, point the mouse cursor to the parameter's name and click right mouse button. A menu appears, allowing to select a presentation option:

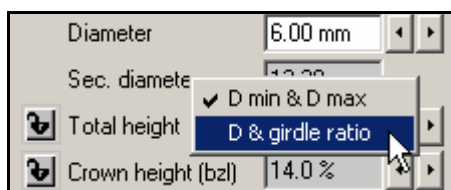

The picture above was taken when the mouse cursor was over «Sec. diameter» field and the right mouse button was pressed. As you see, a menu allows to select between



showing maximum and minimum diameters or just one diameter and ratio of diameters.

There are other dual parameters:

- Girdle square deviation <-> Alternative diameter (measured at direction 45°);
- Star facet length <-> Table picture square-likeness.

There is also a similar way to choose mass precision: 2 digits after decimal point <-> 4 digits.

### 8.3 Getting additional information of parameters

If meaning of some parameter is not clear, move mouse cursor to the corresponding box and leave it there, not pressing any keys or buttons. In couple of seconds, a hint with the description of the parameter will pop up.

For example, move the mouse cursor to the value of parameter Sec. diameter the following effect will produce

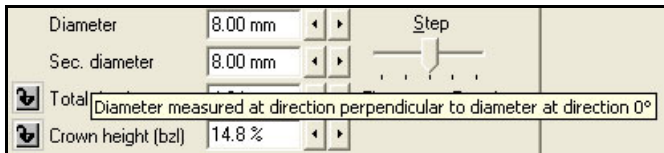

### 8.4 Selecting units of measurement

DiamCalc allows to choose the most convenient representation form or measurement units for some parameters. Diamond Calculator presents options of parameters' units of measurement, when applicable (e.g. linear size can be expressed in millimeters or as a percentage of the diameter). Another way to customize DiamCalc is to select one of several similar parameters. See examples below for more details.

By default, size parameters are presented as a ratio of the corresponding value to the diameter. In some situations, other units, e.g. millimeters, can be more useful. The user can choose measurement units for each particular parameter.

To do this, point the mouse cursor to the parameter value and click right mouse button. A menu appears, allowing to see available units and select one of them:

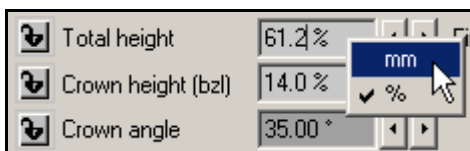

The menu above was produced by pointing the mouse to the value of «Total height» parameter and pressing the right mouse button. A check mark shows that the current unit of measurement is percents of the diameter. If «millimeters» is selected from the menu, a value will be recalculated and shown in a new format.

When values of parameters are entered from the keyboard, units of measurement can be specified along with values. When a string like «1.1 %» or «0.02 mm» is typed, DiamCalc recognizes what is the value and what is the unit of measurement and

change them if needed. If only a number is typed, DiamCalc applies the current unit of measurement.

### **8.5 Finding unknown parameters**

DiamCalc allows to recover values of diamond proportions that cannot be measured directly (e.g. because stone is mounted).

Diamond Calculator is designed to give maximum flexibility in a wide range of situations. Mounted stones can be difficult for direct measuring, and in different cases some parameters may or may not be available.

Another challenge is to estimate a parameter in a diamond that does not exist yet, given proportions of a rough diamond, a semi-cut diamond or a polished diamond that will be re-cut. With Diamond Calculator, this task is as easy as the previous one. Any set of existing limitations can be entered into DiamCalc to find missing parameters of a future diamond without any tables or formulas.

The simplest way to estimate unknown parameters with DiamCalc is just to enter all known values. DiamCalc will produce a reasonable estimation of other parameters.

In practice, the process can be a bit longer due to the fact that the parameters can affect each other. For example, changing crown angle will lead to a change of either the table diameter or the crown height. Relationships between parameters can be quite complex. To neutralize this effect, it may be required to adjust parameter's value once more after it was automatically recalculated due to a change of another parameter. One more option of handling this problem is parameter fixing (see below).

Another way to find parameters that cannot be measured directly is to examine the diamond image produced by DiamCalc, adjusting parameters until the computer image looks similar to the real stone. See section on controlling visual representation of the stone for more information.

*Note.* Computing-intensive photorealistic mode is the most suitable for the purpose, so that a powerful enough computer is required to quickly display the image when parameters are changing.

### **8.6 Fixing parameters**

Some parameters have a small button with a lock on it on the left of the parameter's name. These Lock buttons allow to fix the parameter value to avoid an accidental change or a change due to interrelation between parameters.

Example of using Lock buttons (measuring parameters of mounted diamonds).

The user measures diameter and total height of the diamond and enters them in Diamond Calculator, then fixes total depth with Lock button. After that, measuring the crown height and entering it into the software will cause an automatic adjustment of current pavilion depth and girdle thickness in such a way that the total height will not change.

Parameter fixing is also very useful in diamond marking for maximizing the diamond mass with respect to restrictions imposed by a diamond with old cut, a semi-cut diamond, or a rough diamond.



Note. If a proportion allows a choice of units of millimeters or percents of diameter, only the value in percents will be fixed when Lock button is checked, even if a value in millimeters is displayed currently.

## 9 Support for different cuts

DiamCalc supports all main cut types built in the program and allows to import various external cuts.

### 9.1 Internal diamonds cuts

DiamCalc Standard supports follow standard inner cuts: Baguette, Brilliant, Cuboid, Emerald, Flanders, Happy-8, Heart, Marquise, Oval, Pear, Princess 2-chevron, Princess 3-chevron, Prism and Radiant.

To change a cut select it in the list **Shape and cut**:

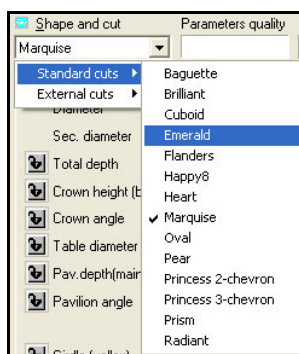

3D model of selected cut is displayed in the left half of Diamond Calculator window.

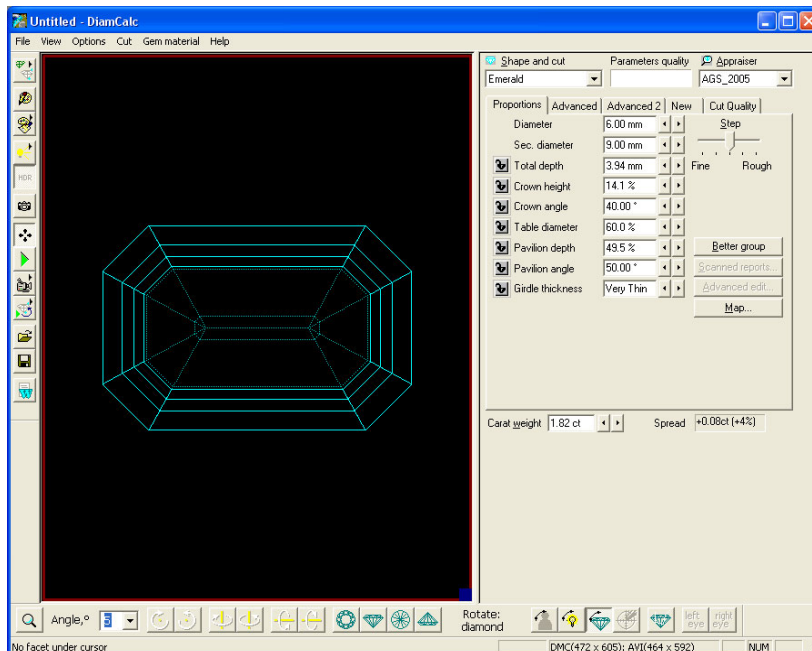

The current shape name is displayed in the field **Shape and cut**.



There is a set of cut parameters common for all cuts. Also there are some advanced cut-specific parameters allows to handle some rare cuts, for example, old round cuts.

*Note. The free demo-version of DiamCalc supports Marquise, Brilliant and Cushion cuts. Parameter changing is available for Marquise cut only.*

## 9.2 Import and export external cuts

DiamCalc allows users to import cut designs and 3D-models of real stones generated with another software. This option includes cut designs made with GemCad software, diamond 3D-models obtained with Sarin machines and OctoNus diamond scanners. If the model is convex it is possible to adjust the size of its model, crown, pavilion, girdle heights, table and culet offsets and position for every facet.

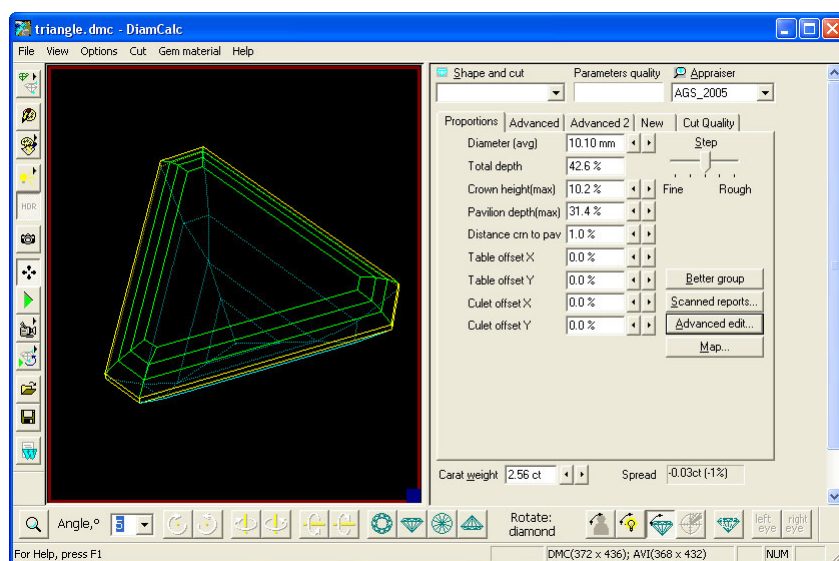

The following file formats are supported:

- **DXF** - AutoDesk *Drawing Exchange Format*
- **ASC** - [Gemcad](#) ASCII format. Design your own diamond shape or get one of the 3700 unique faceting designs from the [DataVue2](#) library and see its appearance with the DiamCalc.
- **STL** -*Stereo Lithography* format. DiamCalc supports ASCII and binary versions of this format
- **MMD** - OctoNus format. File of this type contains 3D-model of real stone built by OctoNus diamond Helium scanners. For details about these scanners visit our web-site <http://www.octonus.com>
- **SRN** - Sarin file format. File of this type contains 3D-model of the real stone built with several types of Sarin machines.
- **TXT** – file with parameters

To import 3D models select format type from menu **Cut / Import Cut**

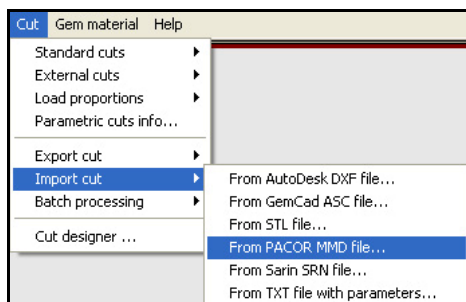

To export 3D models select target format type from menu **Cut / Export Cut**

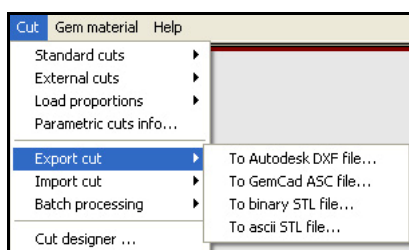

## Import diamond 3D-model from SRN files

There are several ways of receiving Sarin (\*.srn) files to your computer:

1. Sarin users, who own a DiaMension or DiaScan machine, have a possibility to pack their information pertaining to a specific stone into a Sarin file (.srn). Please refer to Sarin web site to get information about the necessary software updates: <http://www.sarin.com/viewer/>
2. RapNet Members ([www.diamonds.net](http://www.diamonds.net))
  - When searching for diamonds select **Display stones with Sarin data only** in the bottom of the Diamond Search Form
  - In the **Search Results** click on the **Sarin** picture in the selected row
  - **Sarin Web Viewer** will be prompted to install
  - Once Sarin Web Viewer is installed the information about selected diamond will be presented
  - Press button **Save...** in the upper part of viewer
  - Notification about name and location of the saved file displayed
3. Receiving \*.srn files from partners and friends via e-mail, on CD etc.



To import SRN file:

- Select menu command **Cut / Import cut / From Sarin file** in the DiamCalc
- **Open** file dialog appears
- Select SRN file



*Note.* By default initial folder is the folder where the Sarin Web Viewer saves downloaded files. If you want to change the default folder then modify the folder in the parameter **Sarin files folder** of the registry key:

*HKEY\_CURRENT\_USER\Software\OctoNus Software\DiamCalc\Settings*

- Press **Open**

If the model is imported successfully work with it as usual. It is assumed that the model in SRN file is convex. If the model is not convex, some of its parts may be cut off.

## Import and export DXF files

In the DiamCalc use the menu command **Cut / Import cut / From AutoDesk DXF file**. You will be presented with **Open file** dialog allowing you to select file you want to import.

*Note.* The limited support of the DXF format is implemented in the DiamCalc (only **Mesh** type data is supported). This means that there is no guaranty that an arbitrary dxf file will be imported into the DiamCalc, but we successfully imported all diamond dxf-files we download from several sites.

Select the desired file and click **Open**. If the model is imported successfully you can work with it as usual. It is assumed that the model in DXF file is convex. If the model is not convex, some of its parts may be cut off. Here is the link to web- resource with a great number of downloads of free DXF cut models: [www.3dlapidary.com](http://www.3dlapidary.com)

With the menu command **Cut / Export cut / To AutoDesk DXF file** you can save any cutting you have in the DiamCalc (including imported models) to this format and then work with this file in the desired 3D software (AutoCAD, 3Dstudio Max etc).

## Import and export GemCad ASCII files

In the DiamCalc use the menu command **Cut / Import cut / From GemCad ASCII file**

You will be presented with **Open file** dialog allowing you to select file you want to import. Select the desired file and click **Open**. If the model is imported successfully you can work with it as usual. It is assumed that the model in ASCII file is convex.

With the menu command **Cut / Export cut / To GemCad ASCII file** you can save any cutting you have in the DiamCalc (including imported models) to this format and then work with this file in the GemCad software.

Please note, that the coordinate system of GemCad does not match the coordinate system of DiamCalc. DiamCalc uses common right-hand coordinate system, while GemCad uses left-hand coordinate system. The X axis in DiamCalc goes to the right, and Y axis goes up by default. Sides' azimuths and indices are calculated from the X axis, so the side with zero azimuth appears on the right.

*Note:* GemCad software can't handle models that exceed the cube 2x2x2 mm in size. It simply cuts off the model by such a cube. You may want to reduce the model diameter before export so that it fits a 2x2x2 mm cube.





## Import and export STL files

Use menu command **Cut / Import cut / From STL file**

You will be presented with Open file dialog allowing you to select file you want to import.

Select the desired file and click **Open**. If the model is imported successfully you can work with it as usual. It is assumed that the model in STL file is convex. If the model is not convex, the program will build convex hull of all vertices of the model.

With the menu command **Cut / Export cut / to binary STL file...** and **To ASCII STL file...** you can save any cutting you have in the DiamCalc (including imported models) to this format and then work with this file in the desired 3D software.

## Adjusting shape of arbitrary imported 3D model of the diamond

DiamCalc allows to adjust parameters of convex models: diameter of the model, crown height, pavilion height, distance between crown and pavilion, table offset, culet offset.

DiamCalc calculates 360 diameters of the model with the step of half a degree and takes the average value as the primary diameter. DiamCalc distinguishes crown, girdle and pavilion facets and remembers the type of each facet. Then it calculates the maximum height of the crown and pavilion as the difference between the highest and the lowest vertex among crown and pavilion facets respectively. It calculates the height of the whole model as well. The distance between crown and pavilion is the difference between the height of the whole model and heights of crown and pavilion. That is why, by the way, this distance may appear negative, if the highest vertex of pavilion is higher than the lowest vertex of the crown (assuming that crown itself is placed above pavilion). This may happen on real cuts. Thus DiamCalc calculates the minimum girdle height and maximum crown and pavilion heights. After the girdle is analyzed, the whole model is shifted along vertical (*Z*) axis to put its center of the mass in the center of the girdle.

To adjust global parameters change it in the tab **Proportion**.

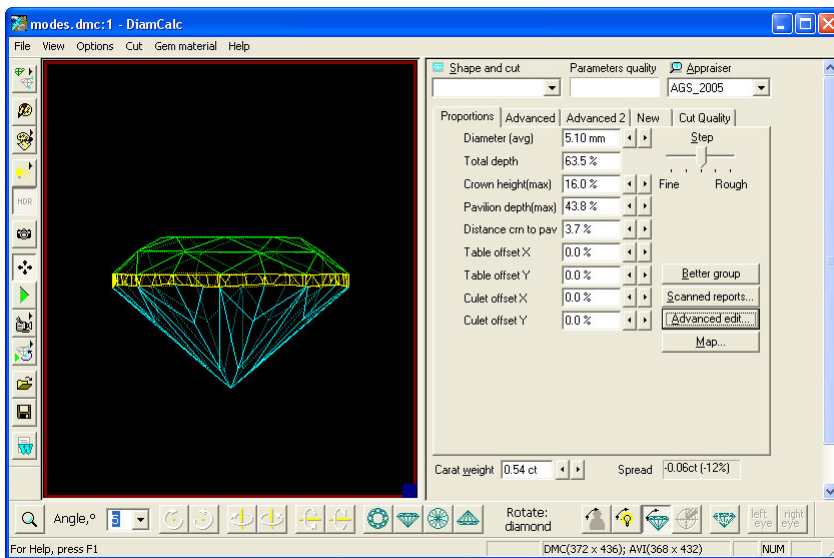

The values of table and culet offset parameters are not estimated during import of the model and they are always set to zero at first. So it is possible to adjust the offsets with these parameters.

Along with global model parameters like crown and pavilion heights that apply to the whole model, DiamCalc supports local parameters allow to adjust each facet. Local parameters describe the deviations of each side from the whole model. These deviations do not depend on global parameters.

To open the window for detailed editing of the model press button **Advanced edit...**

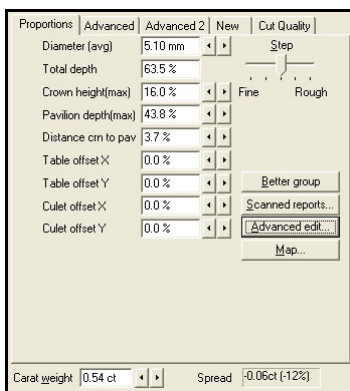

Advanced cut edit window appears.

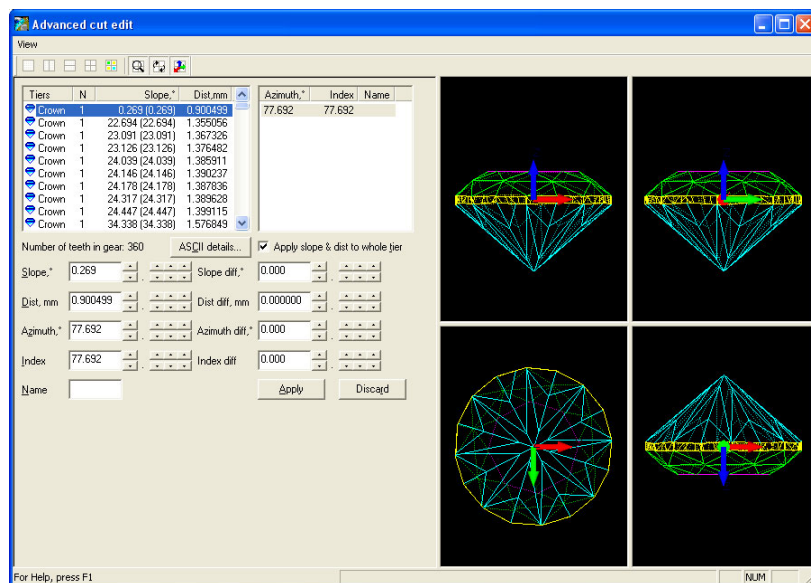

The window shows four views of the model. These views may be rotated with left mouse button, shifted with right mouse button and scaled with mouse wheel synchronously and independently. All these transformations apply only to the position of the camera that shows the model from the main window, but they don't change the position of the model itself. On the other hand, the rotation of the model in the main window changes its position that is why it is reflected in all views.

DiamCalc automatically divides all facets of the model into tiers, similarly to GemCad. The tier comprises facets with identical slope angle and distance parameters.

Window **Advanced cut edit** shows the list of all tiers and the list of all facets within the tier. The facet selected in the list is highlighted on the model. The local parameters of the facet are slope angle, distance, azimuth angle (or gear index). The advanced window allows adjusting of the facet position by adjusting its parameters.

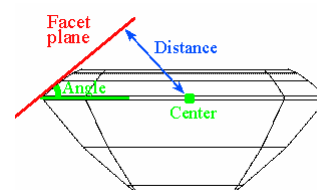

DiamCalc shows deviations of these parameters from initial model as well as the resulting values. When you alter the position of facets the model on the screen is changed instantly, but the global parameters are not recalculated. In order to change the initial model permanently, use button **Apply**. It will substitute the initial model with the current model and all global parameters will be recalculated from a scratch. You may discard the changes in local parameters by the button **Discard**. This will reset the position of all facets and zero all local parameters.

It is not recommended to adjust global and local parameters simultaneously, because local parameters describe absolute deviation of the facet from the current model. If you change the whole model via global parameter, these deviations will become incorrect, which will result in incorrect model shape.

## 10 Working with the different types of gemstones

DiamCalc allows to get photo-realistic images of different types of gemstones: Emerald, CZ and many other. It is possible to change manually gem material characteristics according to external information available about a certain stone.

### 10.1 Select type of gemstone built-in DiamCalc

To set type of built-in gem stone select it from menu **Gem material / Standard types/**

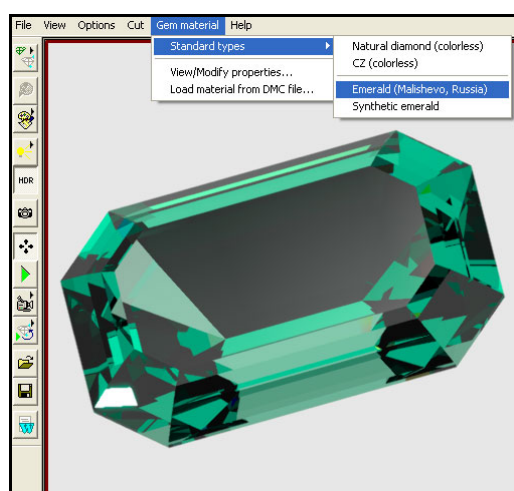

For the time being the following built-in materials are available:

- Natural diamond
- CZ (colorless)
- Emerald (Malishevo, Russia)
- Synthetic emerald

### 10.2 Adjusting gem material characteristics

To adjust gem materials properties open panel **Gem materials** from menu **Gem material / View/Modify properties...**

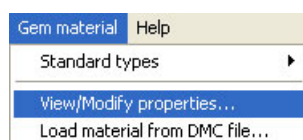

## The General tab

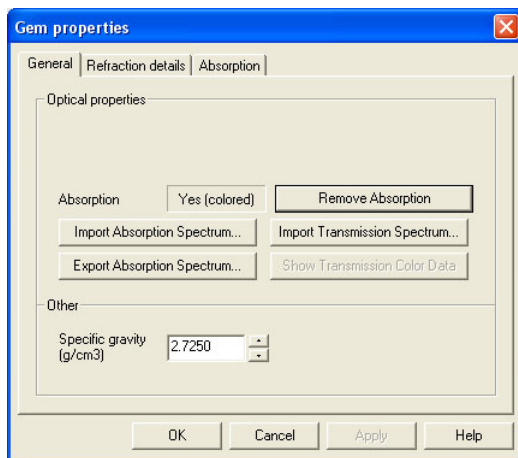

The **General** tab of **Gem properties** panel allows to:

- Define the material density
- Import / Export Absorption Spectrum
- Import Transmission Spectrum
- Set the gem is colored or colorless

## The Refraction tab

The **Refraction** tab allows to adjust gem refraction.

The most right way to adjust the refraction to simulate specific gem is to input the RI value at each wavelength using the *spectrum* grid.

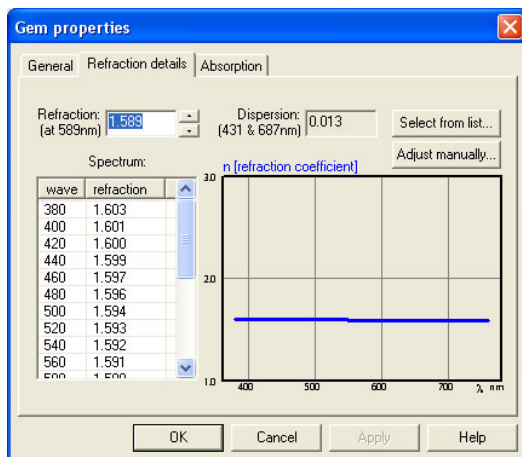

When change just the *refraction* parameter the arithmetical difference is added to all RI values in the spectra. The dispersion in this case isn't changed. This allows to adjust quickly and conveniently gem properties for groups of analogous materials have almost the same dispersion and different RI.

If you haven't whole-spectrum RI data then you may approximate required RI values basing on a couple of values you have. Press button **Adjust manually...** to supply arbitrary RI and dispersion values.

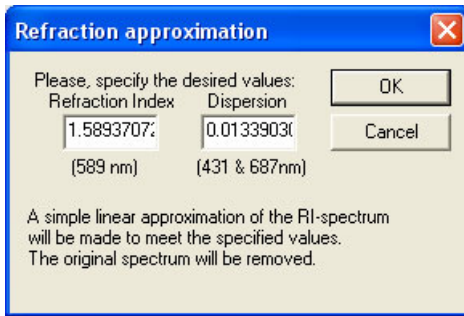

The software will make the linear approximation to meet the specified requirements. The button **Select from list...** opens **Gem material list** with pairs (RI and dispersion) corresponding to most gem materials.

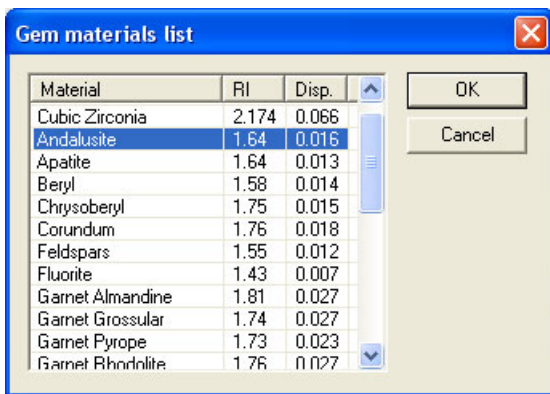

However, by selecting the desired gem material type from this menu you affect only the refractive features of the material, but the absorption and specific gravity stay unchanged after this action.

## Absorption tab

The **Absorption** tab (for colored gems) has the same structure as **Refraction** tab. It displays the spectrum of absorption on a diagram and allows you to modify it. The absorption values must be adjusted for 1mm thickness.

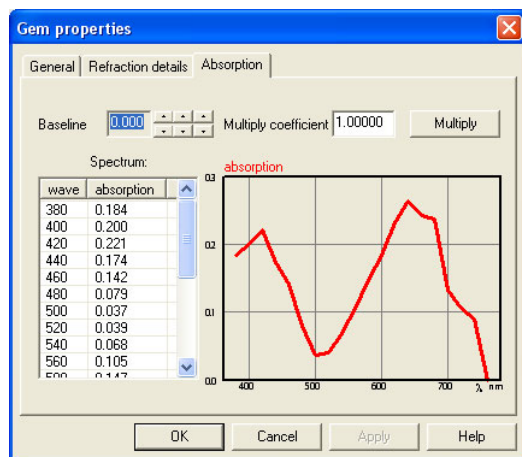

### 10.3 Visible adsorption spectra and DiamCalc-files of colored gem materials

Visible adsorption spectra are available on our web-site for:

- Amethyst
- Corundum
- Cubic Zirconium
- Diamond
- Emerald
- Sapphire
- Synthetic diamond
- Topaz
- Quartz

Spectral data was obtained with SF-56A spectrophotometer in the 370 - 770 nm range, 1 nm step in Moscow State University Gemological Center. Spectra were recorded through two opposite parallel windows of the sample in room temperature.

All spectral data recorded on the spectrometer were converted into an adsorption coefficient in mm-1 taking into consideration the thickness of the sample and the refraction coefficient of the gem material. All spectral data for natural (untreated) colored diamonds was averaged with 20 nm step.

A Prism model with similar thickness as used for spectral data collection was selected in DiamCalc (for polished stones - Helium scanned 3D model of radiant cut). Light conditions for the prism in DiamCalc files: one transmitted source type A (for polished stones 3D models: the standard Dialite DiamCalc lighting).

Corresponding absorption spectra used for modeling are available in the Microsoft Excel format.

The example of spectra and modeling gem stone of amethyst:



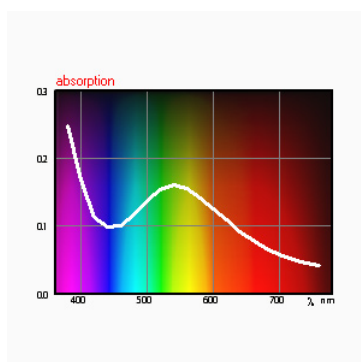
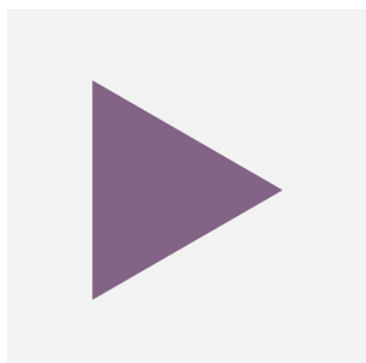

Amethyst violet. **A moderate violet natural amethyst spectrum obtained through 10 mm thick plate along an arbitrary direction.**

Download visible adsorption spectra from our web-site:

[http://www.octonus.com/oct/projects/adsorbtion\\_spectra.phtml](http://www.octonus.com/oct/projects/adsorbtion_spectra.phtml)

## 10.4 Importing and analyzing transmission spectra

To import transmission spectra:

- Select from menu **Gem material / View / Modify properties...**
- Press button **Import Transmission Spectrum...**

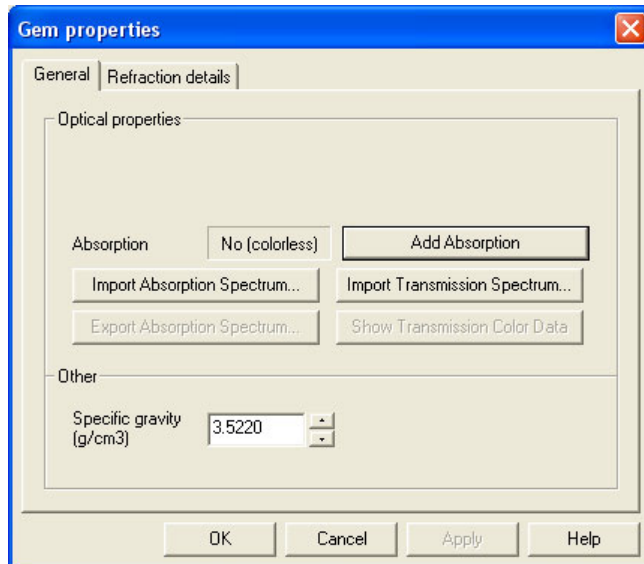

- Import two selected files with energy spectrum of the tested sample and the direct light source.

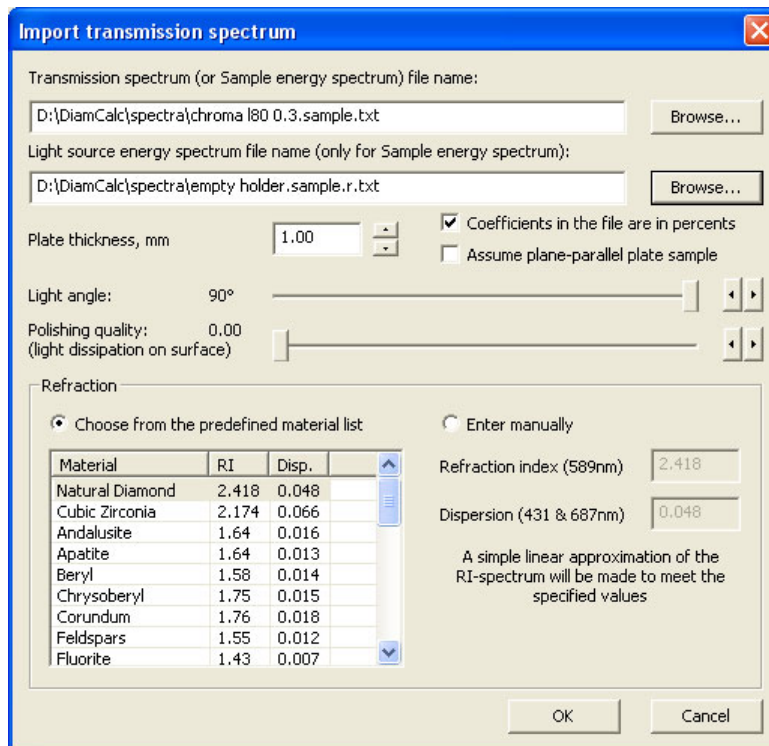

Import of data file with percentage of transmission for each wavelength is available. Calculating absorption spectrum from transmission with assumption of nearly-ideal plane-parallel plate.

Analyze color of the spectrum after importing transmission spectrum:

- Press button **Show Transmission Color Data** in the panel **Gem properties**:

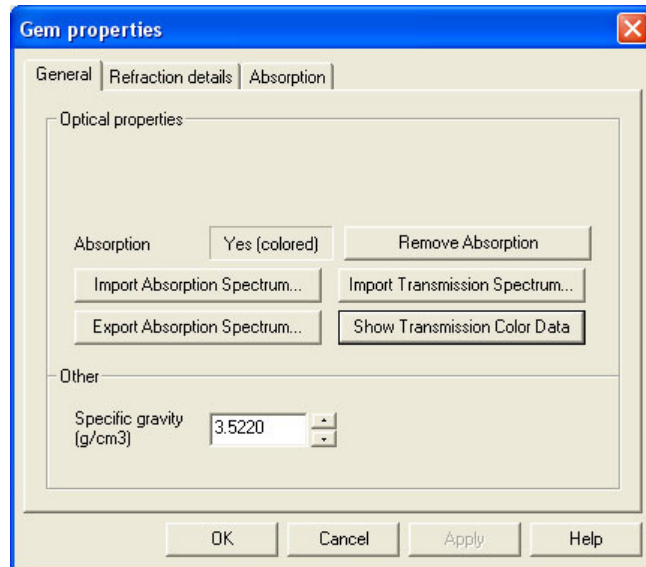

- See color information of imported transmission spectrum

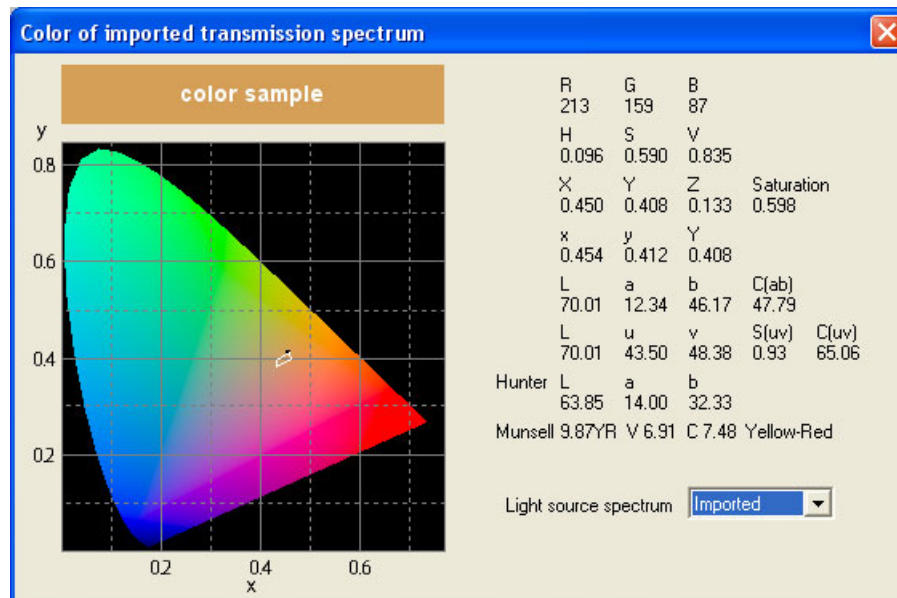

## 11 Cut Quality Estimation

### 11.1 Light Return

In the Diamond Cut Study the light return was measured under different lighting conditions.

To learn how the specific of the human perception is considered in Light Return estimation read section **Taking into account the features of human perception**

To learn more about the difference between **mono** and **stereo** modes read section **Stereoview: Stereovision and evaluation of leakage**

To read more about the Light Return please refer to the following materials:

[Diamond cut study on www.cutstudy.com](http://www.cutstudy.com)

### 11.2 Leakage of Light in Diamonds and Its Estimation

In a diamond, there are some regions that do not return light towards the observer's eye. If we trace those rays connecting the eye with the regions that show no brilliance, we'll find out that some of these rays leave the diamond through its crown but do not propagate towards the source of illumination. Another portion of these rays leaves the diamond through its pavilion, giving rise to the phenomenon called leakage. The third portion of these rays becomes screened by the observer's head or body, giving rise to the effect known as NailHead.

All the three effects cause the observer to see dark, non-illuminated regions in the diamond. Analyzing the leakage and the NailHead effect allows one to reveal such regions of the diamond, which are dark regardless of the type of illumination. It is especially important to determine the parameters of the diamond, for which these dark regions combine into large zones. In such a case, the observer easily notices an abrupt decrease in the local contrast.

It is possible to observe the regions of leakage by placing the diamond into a Firescope that illuminates the stone with white light from the side of its pavilion.



Photo made with the Firescope

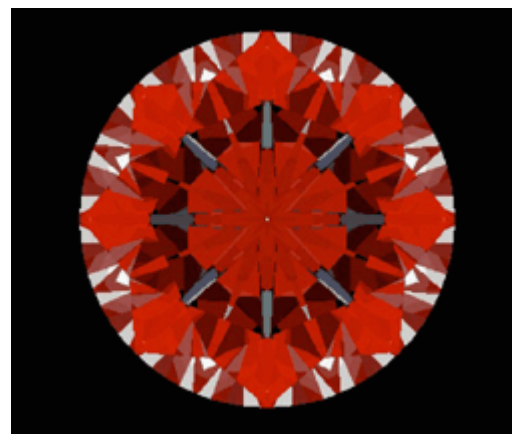

Model of the same diamond, using illumination of the Firescope type

White regions can be seen here and there. Therefore, a light ray passes through these regions from under the diamond to the observer's eye. If such a diamond was mounted into a jewel, we would see the mounting through these regions and would never see any light originating from the illumination source. Therefore, the more leakage regions the diamond contains (and the stronger the leakage effect), the fewer the regions of the diamond, capable of reflecting the illumination into the observer's eye, and the worse the cut quality of the stone.

Theoretically, it is possible to imagine such a location of the illumination source, from which a light ray enters the diamond and splits into multiple rays there, some of these leaving the diamond towards the observer's eye. However, these rays can be only secondary (not primary) ones, which are either quenched due to polishing or become so weak upon leaving the stone that the observer will not perceive them as bright light.

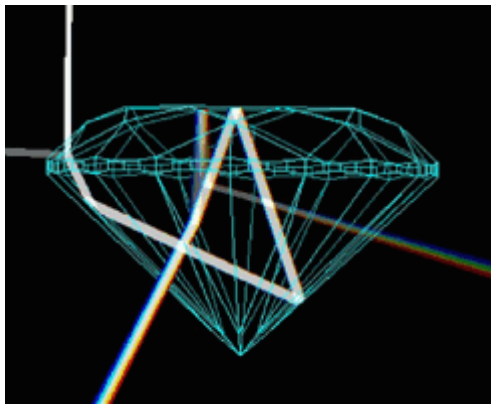

Ray path through a white region

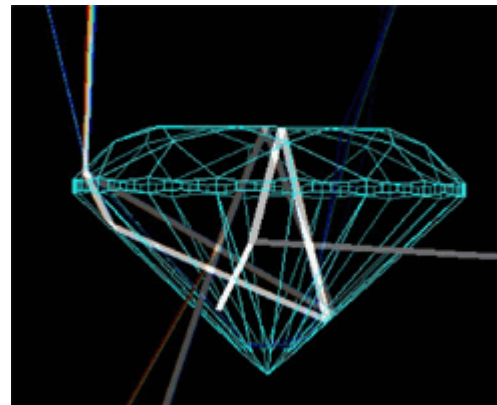

Ray path through a gray region

Besides the white regions, it is possible to notice some gray regions in the stone observed. These regions show partial leakage of light. In other words, some rays leave the diamond through its pavilion, while the other ones leave it through the crown. If a ray originating from the illumination source passes through such a region, the partial leakage attenuates the ray and only a portion of the original ray reaches the observer's eye. This can be demonstrated by tracing the ray as it passes through the white and gray regions:

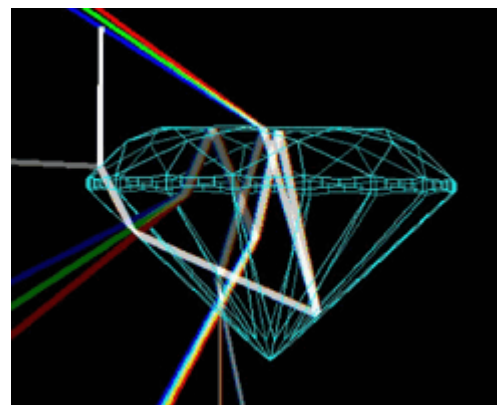
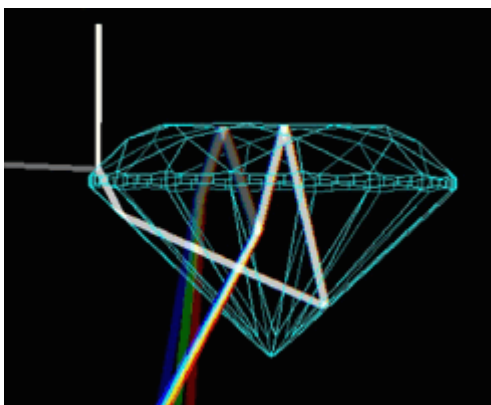



#### Ray path through a white region

#### Ray path through a gray region

To reveal those dark regions caused by light leakage, that is, the regions, which remain dark upon arbitrary daylight illumination of a collet-set stone a model of Leakage-type illumination has been built. The model is a hemisphere located below the pavilion of the diamond and extends up to the girdle plane (upper edge of the girdle). Thus, the model takes into account those rays leaving the stone through its pavilion or girdle.

Those zones of the diamond looking bright upon the Leakage-type illumination will be dark upon usual illumination.

To some extent, this kind of illumination is similar to the illumination from below, used in the Firescope. The main difference between these is the fact that the Leakage-type illumination reveals only light leakage. Therefore, those regions of the stone looking pink under the Firescope illumination are gray under the Leakage-type illumination.

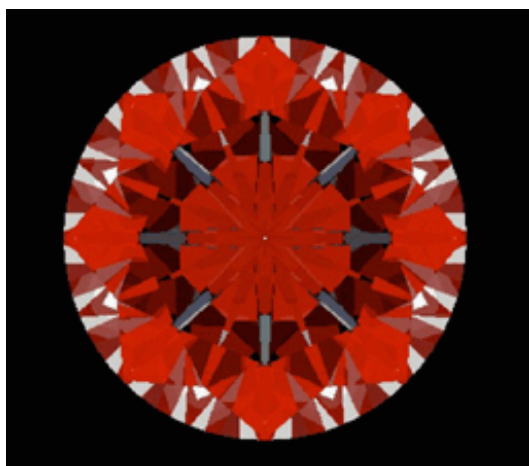

Firescope-type illumination

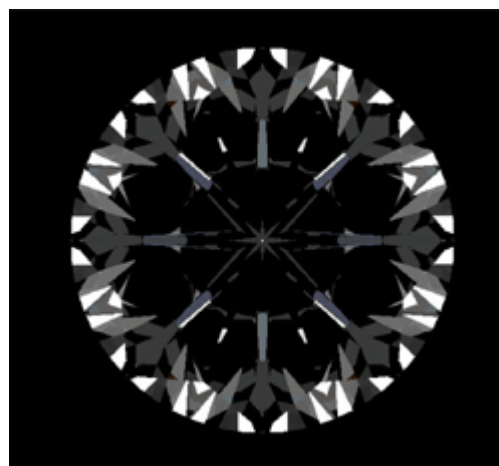

Leakage-type illumination

In order to analyze the cut quality of the diamond and the accuracy of its proportions, it is reasonable to quantitatively estimate the leakage of light. We propose the following way of doing that. The leakage is estimated as the subjective brightness of light that returns to the observer's eye in the case when the illumination of the diamond is of the Leakage type. Here we use a model of photo objective (diameter 150 mm, distance to diamond 60 cm) as a viewer. Here we not take into account human stereoview. We suggest calling this viewer a «Photoreceptor».

Since there are some stones that show considerable leakage primarily through the table, we calculated two leakage types: through the whole crown of the diamond (plot 1) and through the table solely (plot 2). Those portions of the plots characterized by large leakage values represent undesirable proportions of the stone, that is, those cut parameters causing considerable leakage of light either through the crown or through the table.

When analyzing these plots, it turns out that they are quite similar to plots of diamond's Light Return. This fact is absolutely reasonable, because the Light Return through the crown and the light leakage through the pavilion should be interrelated. At



the same time, some differences can be noticed, the most interesting one corresponding to the region close to the Tolkowsky's cut parameters (slightly upper on the plot than these). This region looks good from the point of view of Light Return but much worse from the point of view of light leakage. When studying gems belonging to this cut parameter range, one can notice that their Light Return is high only in the «crown looks to the observer» position. When swinging such a stone, its Light Return appears to be lower than that of a diamond cut in accordance with the Tolkowsky's parameters.

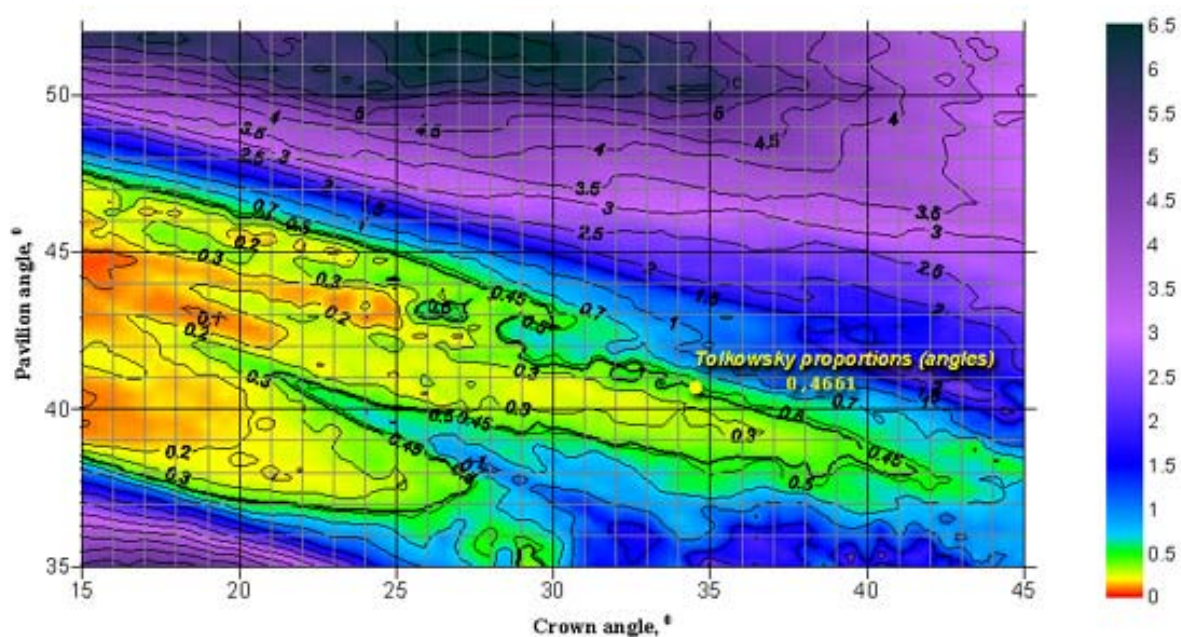

Plot 1. Light leakage through the crown of a round brilliant cut diamond with a table spread of 57% and a girdle thickness of 1% as a function of the crown angle and the pavilion angle. The distance between the photoreceptor and the diamond is 60 cm. The plot is based on the image observed by photoreceptor. The diamond is oriented so that the table looks towards the observer. The larger the leakage value plotted, the stronger the leakage effect and the lower the quality of the diamond.



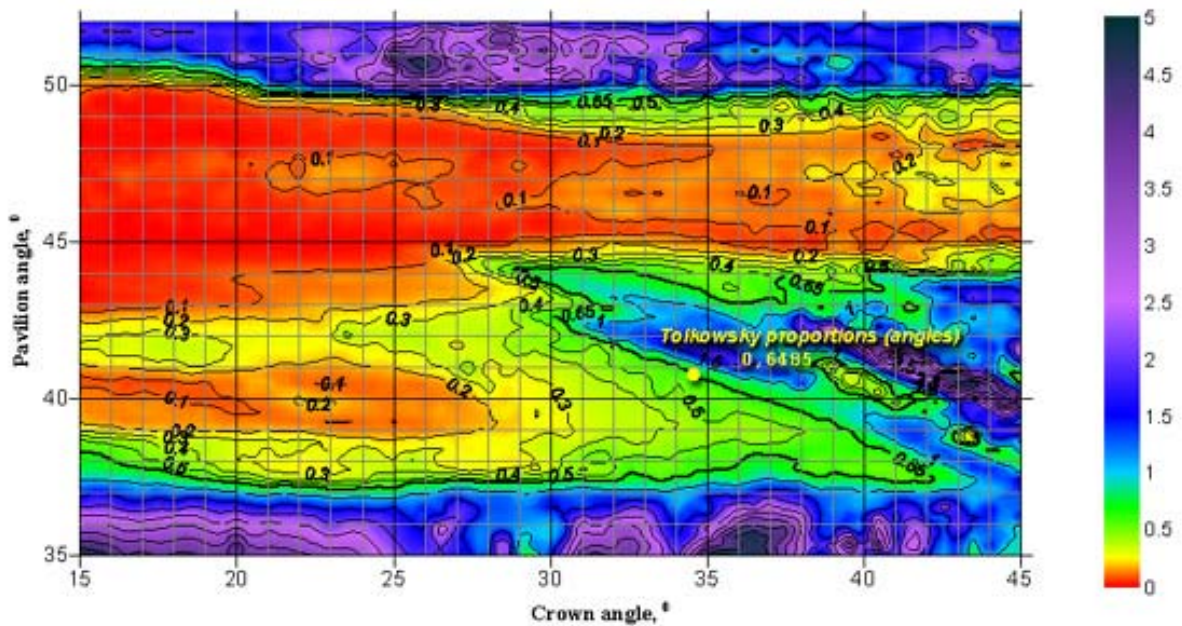

Plot 2. Light leakage through the table of a round brilliant cut diamond with a table spread of 57% and a girdle thickness of 1% as a function of the crown angle and the pavilion angle. The distance between the photoreceptor and the diamond is 60 cm. The plot is based on the image observed by the photoreceptor. The diamond is oriented so that the table looks towards the observer. The larger the leakage value plotted, the stronger the leakage effect and the lower the quality of the diamond.

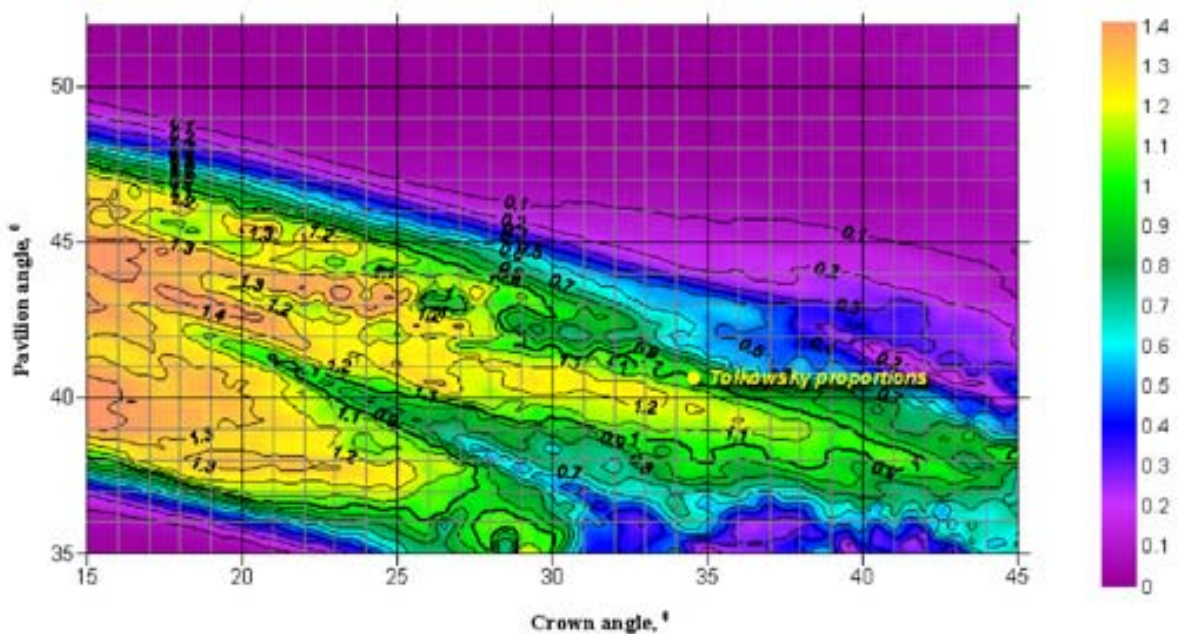

Plot 3. Adapted leakage calculated for the table of a round brilliant cut diamond with a table spread of 57%. The position of the stone is static; photoreceptor.

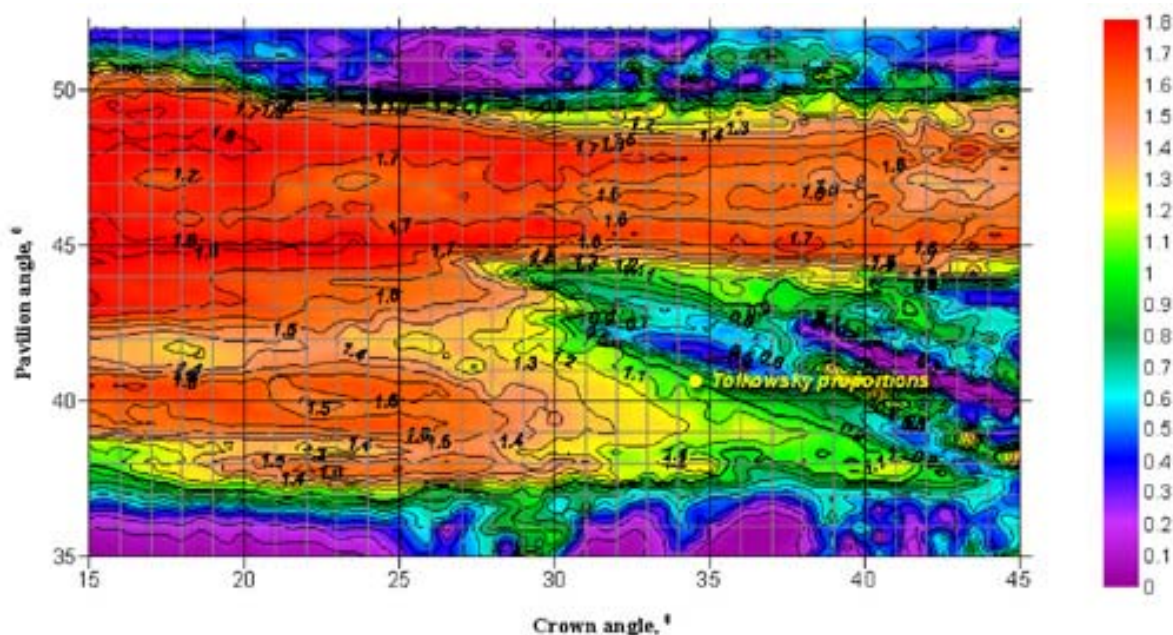

Plot 4. Adapted leakage calculated for the crown of a round brilliant cut diamond with a table spread of 57%. The position of the stone is static; photoreceptor.

When studying the effect of light leakage, an inversion function was introduced, which is required to adequately take into account the leakage during the geometric averaging. So, the stronger the leakage, the smaller the leakage measure supplied to the averaging procedure. Only in this case the geometrical averaging will cull out those stones showing strong leakage of light. Another purpose of using the inversion function is correct normalization of the leakage value with respect to the Tolkowsky's cut parameters. The leakage value for these parameters should be 1. Otherwise, a mismatch arises between modeling light return and other effects, violating the resultant brilliance function that takes into account both the brilliance and effects.

We propose to refer to the value of leakage, obtained with the use of the subjective grading and inversion functions, as **the adapted leakage**.

### **11.3 Stereoview: Stereovision and evaluation of leakage**

The human nature of seeing is stereoscopic. When we look at an object by two eyes, each eye sees its own picture, and these pictures are different one from another.

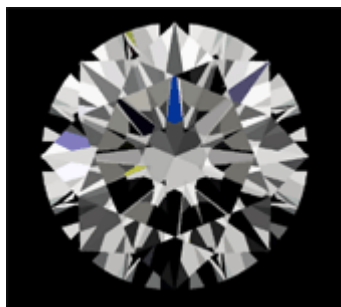

The flat image of a diamond in the face-up position. This is the way as a photo camera sees

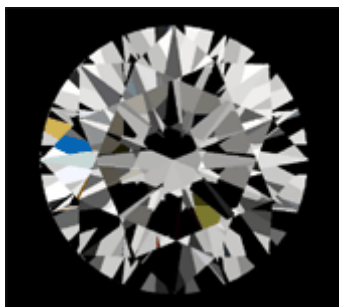

The same diamond observed by the left eye

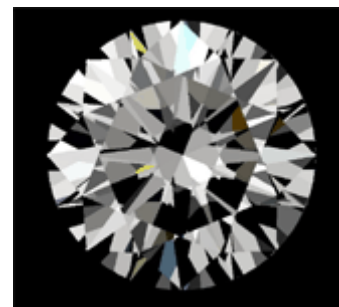

The same diamond observed by the right eye

Human brain transforms two pictures into stereoscopic one. How does it happen? Is it correct that the brain observes the same picture as the photo camera does? Actually work of the brain on the creating of one stereoscopic image from two initial ones is not a simple averaging of two pictures. The image in the brain can be absolutely different from the average picture seen by the right and left eye correspondingly as well as from the image seen by the «photoreceptor» where the image is the result of observation along one direction.

Considering this phenomenon in application to the leakage of light in diamonds, we face the task how to evaluate areas in diamonds, in which one eye sees the leakage and the other eye does not. In other words what will be in the human brain when one eye observes the white area while the other eye sees the dark one. In this case the human brain will see the white area. When at least one eye sees leakage then the resulting image is also perceived as leakage. For the white background the situation is opposite - the brain feels the black section as the result of superpositioning two pictures.

Another consideration is the case of partial leakage areas in a diamond. On the figures shown below there's a partial leakage under the table seen by the right and by the left eye correspondingly in the «Leakage» model of illumination:

Human brain transforms two pictures into stereoscopic one. How does it happen? Is it correct that the brain observes the same picture as the photo camera does? Actually work of the brain on the creating of one stereoscopic image from two initial ones is not a simple averaging of two pictures. The image in the brain can be absolutely different from the average picture seen by the right and left eye correspondingly as well as from the image seen by the «photoreceptor» where the image is the result of observation along one direction.

Considering this phenomenon in application to the leakage of light in diamonds, we face the task how to evaluate areas in diamonds, in which one eye sees the leakage and the other eye does not. In other words what will be in the human brain when one eye observes the white area while the other eye sees the dark one. In this case the human brain will see the white area. When at least one eye sees leakage then the resulting image is also perceived as leakage. For the white background the situation is opposite - the brain feels the black section as the result of superpositioning two pictures.





Another consideration is the case of partial leakage areas in a diamond. On the figures shown below there's a partial leakage under the table seen by the right and by the left eye correspondingly in the «Leakage» model of illumination:

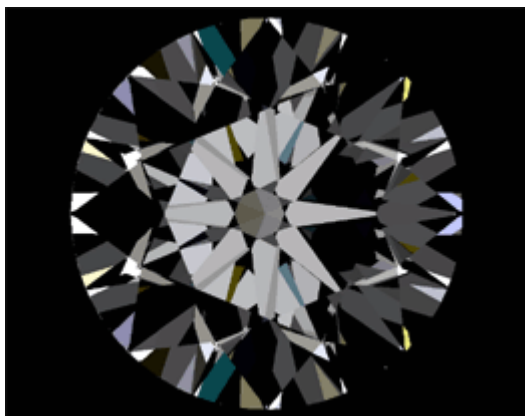

Picture for the left eye in the «Leakage» illumination

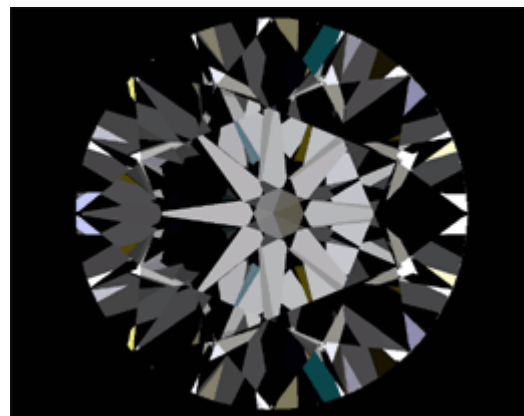

Picture for the right eye in the «Leakage» illumination

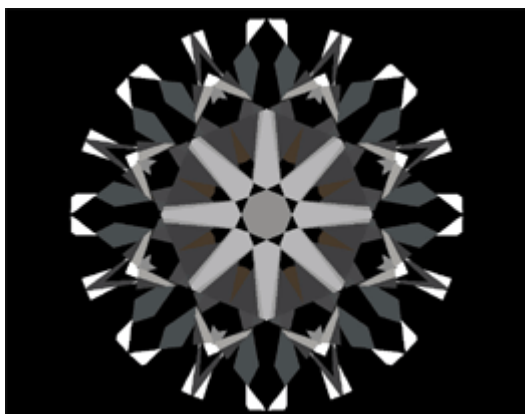

The average picture: weak partial leakage under the table

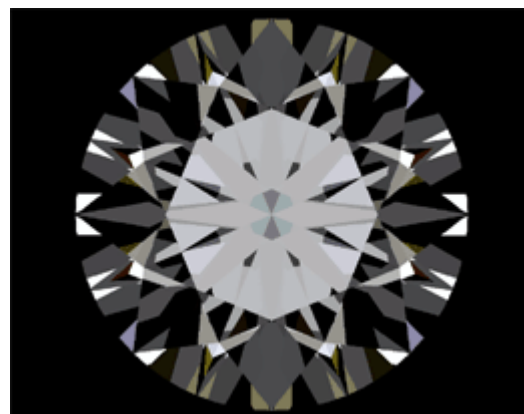

The result of stereo effect calculation: moderate leakage under the table

Literally all the modern conceptions of the diamond cut investigations will bring to the conclusion that the result leakage through the table is negligible for this diamond. It can be shown in the Firescope or in the «Leakage» illumination for the average position of the stone.

Taking into account stereovision effect lets us conclude that the result leakage seen by the brain through the table will be more considerable:

These examples show the work of stereo mode applied in this software. It evaluates the leakage of light from the point of view the real observer - the human head with stereovision.

## 11.4 Taking into account the features of human perception

The necessity of taking into account the psycho physiological factors of human perception of the appearance of a diamond has changed the modeling methods used in gemological studies. In particular, a number of special functions, such as subjective brightness, subjective grading, and weighed geometric average, have been introduced.

### Subjective brightness function

If an observer is provided with a number of grayscale color samples and asked to select such a gray tone that equally differs from white and from black, he faces a considerable difficulty, because estimating the relative value of two considerable color differences is based solely on a subjective impression. However, the required gray tone can be determined by averaging the subjective estimations of a few observers. Then, the same method can be applied to the two color ranges obtained (the first is from black to middle-gray; the second is from middle-gray to white). As a result, a uniform-contrast scale of luminosity (subjective brightness) can be built. This was one of the methods used to define a grayscale in Munsell's color space. One of the first formulas to determine this scale was the square root of the brightness (intensity),  $V = \sqrt{Y}$ . It is worth noting that a power law is suitable not only for defining subjective visual scales, but also for describing the human perception of sound intensity and some other characteristics. In other words, to make the human perception twice stronger, the intensity of the external action should be increased 4 times. In 1964 CIE approved a cube root formula,  $V = 25 \cdot \sqrt[3]{Y} - 17$  which well fits the Munsell's square-root luminosity scale for Y ranging from 1 to 100. These formulas do not take into account adaptation of the observer's eye to the background. At the same time, the background level strongly affects the subjective brightness of an object. You may feel it by comparing two gray squares of the same intensity, surrounded by a black and a white background. On the basis of experimental results obtained by Kaneko, Takanashi, and Semmelroth, it has been shown that the following formulas are more adequate for calculating the subjective brightness of an object, depending on the background level:

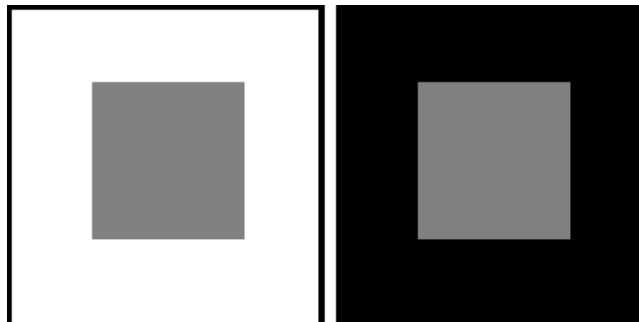

$$\begin{cases} V = Y^n + k(Y - Y_{BG})^n, & Y \geq Y_{BG} \\ V = Y^n - k(Y - Y_{BG})^n, & Y < Y_{BG} \end{cases}$$

where V is the subjective brightness (or luminosity) of the object; Y is the intensity (luminance) of the object; YBG is the intensity (luminance) of the background that

surround the object;  $m$ ,  $n$ , and  $k$  are coefficients that determine the relative contributions of human stimuli. It is empirical fact that the most appropriate values of the latter coefficients are the following:  $m=0.4$ ,  $n=0.2$  and  $k=0.65$ .

We used a slightly modified version of the above formulas to estimate the brilliance of a diamond and leakage of light in it.

### Subjective grading function

People usually grade various phenomena using a discrete set of categories (such as «bad», «good», «perfect», etc.) rather than percent scale or another continuous measure. It can be said that people have natural bias towards discrete grading of phenomena, even if the physical characteristics of these phenomena change continuously. That's why we have introduced a so-called three-step Grading Sigmoid as a measure of human rating of phenomena studied. The conventional sigmoid function often used in mathematics (see the plot below) represents only two levels, while people use at least three levels to grade events. So, we had to slightly generalize the sigmoid function for our purposes.

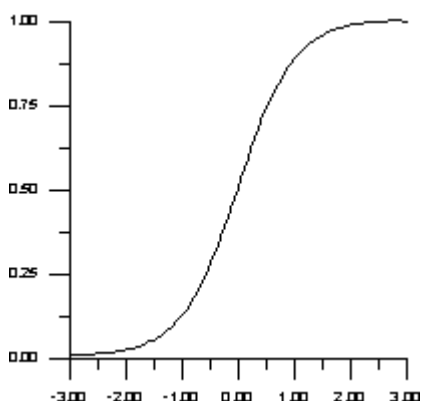

$$f(x) = \frac{1}{1 + e^{-ax}}$$

### Weighed geometric average function

When modeling a grading procedure of a cut diamond, it is not enough to take into account only a single static position of the stone. This is because a real observer would view the diamond from different sides. Therefore, we performed all the necessary computations for 15 orientations of the stone (it was rotated by 30 degrees around its axis) and then used weighed geometric averaging. The latter procedure reflects human perception more adequately than arithmetical averaging does. The geometrical averaging takes into account two key features of human perception.

The first feature is highlighting some bad views of the stone under study. This means that if the observer notices a bad perspective while changing the stone orientation, the negative impression may last even after the perspective is changed to a more advantageous one. The human perception tends to grade this stone as bad. So, the geometric averaging makes it possible to adequately grade those stones looking bad in some orientations and prevents the negative rating from being compensated by

advantageous perspectives. Such compensation may easily occur if one uses arithmetical averaging.

The second key feature of human perception is that when grading a stone the observer pay more attention to the crown up position. The larger the deviation of the stone orientation from the position when the crown looks exactly towards the observer, the less the *subjective weight* of this orientation in overall grading. Therefore, we made the geometric averaging weighed by taking into account the deviation angle of the diamond from the «crown towards the observer» orientation. The resultant averaging function looked as follows:

$$f(x) = \left( \prod_i x_i^{\cos(a_i)} \right)^{\frac{1}{\sum_j \cos(a_j)}}$$

## 11.5 Brilliance

Below there are all definitions of *Brilliance* that we could find so far (1), our considerations why so many definitions do exist (2), and two definitions of «Brilliance» that match our understanding of this phenomenon (3). This material is a part of our future article devoted to Brilliance and we will be grateful if you share your considerations, concerns and comments.

### Definitions of Brilliance

- GIA Diamond Dictionary, 3rd edition: Intensity of the internal and external reflections of white light from the crown of a polished diamond or other gemstone. Hardness, refractive index, reflectivity, polish, luster, and proportions all affect a gemstone's brilliance.
- Diamond Grading ABC by V. Pagel-Theisen, 11th edition: External brilliance - luster, produced by reflection of light on the surface of the facets; Internal brilliance - refraction and total reflection of light on the pavilion facets; Dispersive brilliance - splitting of scattering of light into its spectral colors = the dispersion which evokes the «fire» or «life» in a brilliant; Scintillation brilliance - the «sparkle» of the stone when moved, caused by light reflections of the light source.
- Dodson's definition (1978): A measure of the light that, entering the crown of the stone, is scattered out of the crown facets.
- «Professional Jeweler» (July 1998) Light Return / Brilliance. The amount of light returned to the eye, or brilliance, depends on how well the diamond in question reflects and refracts light. This includes dispersed wavelengths, which are reflected from the internal surfaces of a diamond and returned to the eye.
- <http://www.pricescop.com>: Brilliance is the most important feature of a beautiful diamond. At the simplest level, brilliance is reduced if light leaks out the back of a diamond. In a more complex analysis, the direction that light



enters and leaves the top of a diamond becomes very important. A very deep pavilion diamond returns light straight back to the viewer, so in fact when you look face onto the table your head blocks the light and the diamond looks dull. Some diamonds that are too shallow suffer a similar problem (with a different cause).

## Discussion

It is well known in gemology and trade that the diamond appearance is described in terms of Brilliance, Scintillation and Fire. These three parts describe the diamond appearance completely.

Literature review and comparison of trade opinions show that the «Brilliance» term is not clearly defined and there is no one generally accepted definition.

Probably about 50 years ago the word «Brilliance» was used as ultimate description of the diamond appearance. At that time it was a synonymous with «Beauty». Evolution of ideas was led to separation of «Fire» as a characteristic of colored part of Brilliance and after that to separation of «Scintillation» what characterized a moving diamond. All that remained after separation of these two properties is known today as «Brilliance».

At present time there are three different ideas of brilliance:

1. Diamond beauty (as 50 years ago);
2. Diamond beauty minus Scintillation minus Fire;
3. Light Return (sometimes including external luster or sometimes taking into account internal reflections only).

**Here we are posting two following definitions of «Brilliance» for your suggestions**

### First definition

Brilliance is the characteristic of a diamond, which remains when we «take» all its appearance and «subtract» Scintillation and Fire. The human eye will see Brilliance as combination of white, gray and black zones for motionless diamond (i.e. colored zones are eliminated).

### Second definition

The phenomenon called Brilliance consists of two parts. The first one is based on comprehension of primary / initial / incipient brightness and contrast of diamond image (motionless photo-shots taken from different positions). The second part consists of posterior / subsequent traditional comprehension of some phenomena as negative or positive (like «Fish-Eye», «Nail Head», «Leakage», thick girdle, symmetry deviations, Tolkowsky pattern, «Ideal Cut»).

This second part appeared due to attempts to grade the first part of Brilliance and to interpret it by viewing many diamonds. And nowadays the members of the contemporary market have in their memory a set of standard images, which people have already associated with positive or negative emotions.

Perhaps to evaluate Brilliance objectively the first part would be well enough, but it would not be enough for a human subjective evaluation because a human mind could hardly grade / calibrate it. It is easier for a human brain to grade / evaluate Fire of Scintillation because under fixed illumination conditions one can easily count «two flashes» or «four bright sparkles during motion» or «no one colored facet». Seemingly the attempt to replace «Brilliance» by «Light Return» is bound up with the very need to grade.

Comprehension of the first part of Brilliance depends on sex and age of people. Comprehension of the second part of Brilliance depends on the environment / culture where people grow. As a consequence the comprehension of the second part of Brilliance will vary for different nations, times, social groups, etc. This phenomenon is similar to tastes (like preferences of types of clothes, wine, women, men, cars, books .... etc).

### **11.6 Contrast**

This is an estimate of subjective perception of diamond's picture in some lighting surround by a human eye, namely is the image more or less "contrast". It is essentially the cumulative length of visible borders between differently colored zones on the image multiplied by differences across these borders both in brightness and chromaticity. Additional reduction of contrast is introduced to take into account the low-contrast perception of very small details of an image such as very small virtual facets that have no potential for our eyes to resolve sparkles or contrasting zones.

### **11.7 Dark Zone**

Dark Zone is an estimate of size and the negative effect of dark zones seen within a diamond. Dark Zones occur when we see parts of a diamond where we cannot see any brighter lights in the surrounding space around the diamond. This part of space is essentially when we can see through to the pavilion-side hemisphere, and the space occupied by implied observer's head and body. The lower the Dark Zone number of a diamond the more probably it will look dark or have unattractive area for a typical observer. Very small and frequent Dark Zones contribute to contrast, very large dark zones detract.

### **11.8 Fish Eye**

Fish Eye is a reflection of the girdle on the pavilion facets visible in the face-up examination of a diamond with a very small pavilion angle. It is one of the optical effects like Kozibe, Nail Head etc. For example a round brilliant that needs more than 5° of tilt to see the girdle will be graded Very Good 1.00, and if the tilt is more than 0.1° and less than 5° it will be graded as Good 0.75. Less tilt than 0.1° receives Poor 0.50.



## 12 Appraising diamonds quality and pricing diamonds

OctoNus Diamond Calculator has two major features that help to evaluate diamonds:

- Appraising diamond quality and quality of particular diamond parameters (girdle size, pavilion angle, etc.)
- Pricing diamonds basing on price lists with discounts for diamond shape, cut quality, color and clarity

By default, the DiamCalc does not display price. To enable or disable price display use menu command View / Prices

There are several built-in systems of diamond grading («appraisers»): AGS, HRD, GIA, AGA and Russian TU. Moreover, the data of appraisers is stored as a text and can be edited, so you can change criteria of appraising diamonds or even add your own grading scheme.

Price lists are also stored as a text, so they can be customized, including possible discounts for diamond shape, color and clarity. Also, there is a free DBFCONV utility which provides a way to use Rapaport price lists with Diamond Calculator.

**DISCLAIMER.** The numerical representation of grading systems used by DiamCalc is not an official data of the corresponding bodies. Although the data was intended to describe HRD, GIA, AGA and Russian TU grading systems as precise as possible, some ambiguities or differences with the official data might exist. OctoNus Software recommends that you check appraiser data and modify it as necessary before using it to grade diamonds for commercial purposes.

**DISCLAIMER.** The price lists supplied with DiamCalc are sample ones. Although they are similar to real price lists used in the diamond industry, OctoNus Software does not guarantee that you can buy or sell diamonds at the price that was calculated by DiamCalc on the basis of the supplied price lists. OctoNus Software recommends that you verify price list data and modify it as necessary before using them for appraising diamonds for commercial purposes.

You can see «How DiamCalc grades diamonds» for exact criteria of diamond grading provided by DiamCalc.

«How DiamCalc prices diamonds» explains how the price is calculated depending on diamond color, clarity, shape and other parameters.

### 12.1 How DiamCalc grades diamonds

When a diamond data is entered, DiamCalc uses a selected grading system («appraiser») to grade each diamond parameter according to tables below. Depending on parameter value, it is given a grade (different grading systems have different quality groups). Then the quality of the diamond cut is calculated as the worst of quality groups of all individual parameters.

This data is contained in Appraise.txt file in the folder where DiamCalc is installed.

There are two kinds of data tables: appraiser tables and translation tables.

Appraiser tables show how each individual parameter is graded. They contain following columns: parameter name, as it is listed in Appraise.txt file; the meaning of the parameter; and one column that lists a range of that parameter for each quality group.



Translation tables give a numerical equivalent for quality groups of some parameters, for instance, they could define a «thick» girdle as having size between 4.75 and 6.25 percents of the diameter.

Tables are ordered by grading system, then by cut. The following systems and cuts are implemented:

- HRD system: Brilliant cut;
- GIA system: Brilliant cut;
- AGA system: Brilliant (different tables for diamonds less than 0.5 ct or 0.5 ct. and more), Pear, Heart, Oval, Marquise, Prince, Emerald and Radiant.

## ***12.2 How DiamCalc prices diamonds***

DiamCalc can estimate a price of the diamond taking into account the mass of the diamond, its cut, color, clarity, quality of cut and a user-defined discount.

The following method is used:

- Base price per carat is calculated with price lists using mass group, cut, color and clarity.
- A discount for cut quality is taken (cut quality is determined by «DiamCalc Appraisers Description»).
- The final price is calculated on the basis of base price per carat, mass, discount for quality of cut and user discount.

Price lists are stored in text files. The main file is Price.txt which is located in the folder where DiamCalc is installed. The shipped version of Price.txt file does not contain price lists itself, but rather has references to OctBrill.txt file (it is located in the System subfolder and lists prices for Brilliant cut) and OctPear.txt file (it is also in System subfolder and contains prices for Pear cut).

Price.txt file also specifies that the price for diamonds of other shapes is a half of the price of the Brilliant cut diamonds with similar other parameters. For the details of individual file formats, see the links below. Note that there are three price list files in the shipped version of the software (Price.txt, System\OctBrill.txt and System\OctPear.txt), but formats of the last two are essentially the same.

## 13 Creating diamond reports

### 13.1 Creating Diamond Grading Reports

Diamond Calculator can create a diamond grading report. This feature requires that MS Word 95, MS Word 97 or later is installed. To create a report select in menu command File / Report (Export to Word)... MS Word will be started, and a new document created. You can view the report or print it from Word as usual. A report describes cut, proportions and contains a schematic image of the diamond.

### DIAMOND grading REPORT

Report No. \_\_\_\_\_

Shape:	<b>Marquise</b>		
Weight:	<b>1.61 ct.</b>	Crown Height	<b>14.00 %</b>
Dimensions:	<b>Max. 13.20 Min. 6.00 x Dep. 3.67 mm</b>	Crown Angle	<b>35.00 °</b>
Total Depth	<b>61.22 %</b>	Pavilion Height	<b>43.46 %</b>
Table	<b>60.00 %</b>	Pavilion Angle	<b>41.00 °</b>
Girdle thickness	<b>Slightly Thick</b>		
Culet			

CUTTING/PROPORTIONS GRADE: **2B**  
according to AGA appraising system.

GIA COLOR: **H**

D	E	F	G	H	I	J	K	L	M	N	O	P	Q	R	S	T	U	V	W	X	Y	Z
Colorless	Near Colorless		Slightly tinted		Very Light Yellow					Light Yellow					Yellow							

GIA CLARITY: **VSI**

F IF	VVS1	VVS2	VS1	VS2	S11	S12	I1	I2	I3
Flawless	Very very small inclusion		Very small inclusion		Small inclusion				
Internally Flawless									

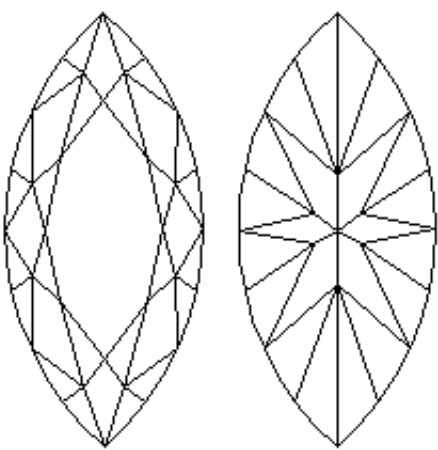

Laboratory Director

Date: September 10 1999

This report is generated with OctoNus Diamond Calculator. <http://www.gemology.ru/octonus>

## 13.2 Creating reports for scanned polished diamonds

The DiamCalc allows to make reports for 3D models obtained by Helium or Sarin scanners

The OctoNus Helium software can export 3D model of the scanned diamond and its parameters to the DiamCalc's DMC file. DiamCalc can read such files and display the scanned model and its parameters. DiamCalc can generate the same reports of scanned diamond as Helium by using data provided by the Helium. For more information about Helium please visit our web-site: <http://www.octonus.com/oct/products/helium/polish/>

### Step-by-step instruction

To make report for scanned diamond follow the instruction:

Import model

Set cutting type

Specify facet types

Calculate report parameters

1. Make report

#### Step 1. Import model

1. Locate file with 3D model in your computer. This file usually has MMD, DMC or SRN extension.
2. **Import** this file into DiamCalc. There are several ways to import the model.
  - Use menu **Cut / Import cut / from Sarin SRN file** or **..Helium MMD**
  - Drag MMD, DMC or SRN file from Windows Explorer into the DiamCalc window.

3. DiamCalc window will look similar to this.

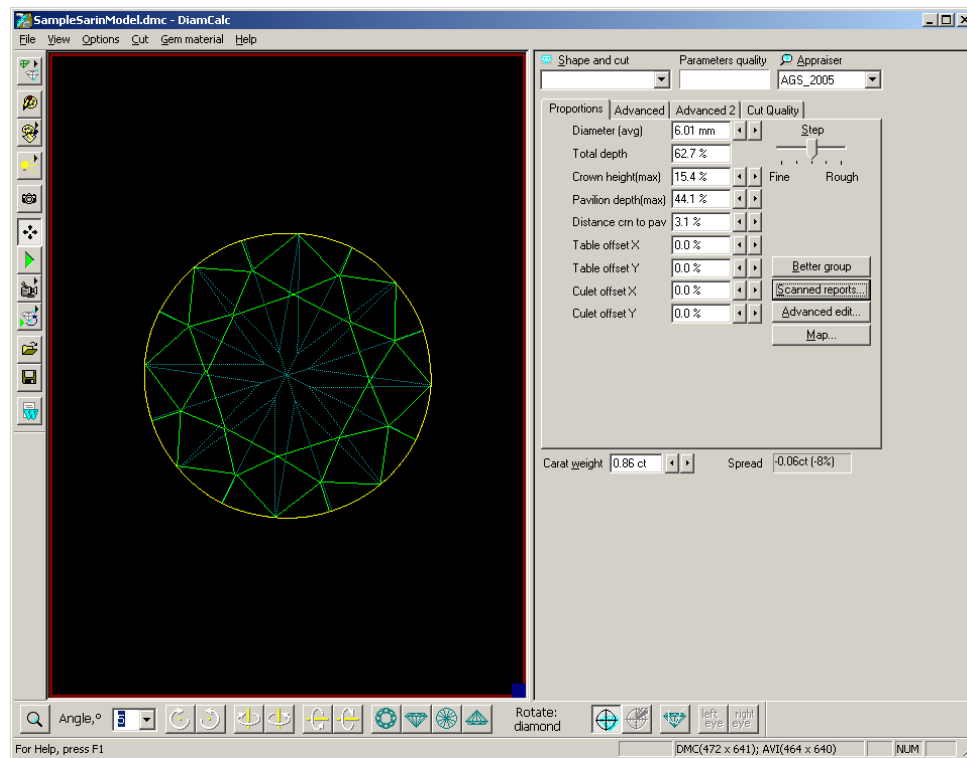

The button **Scanned reports...** becomes enabled. Press this button.

4. The new window **Scanned model reports** opens

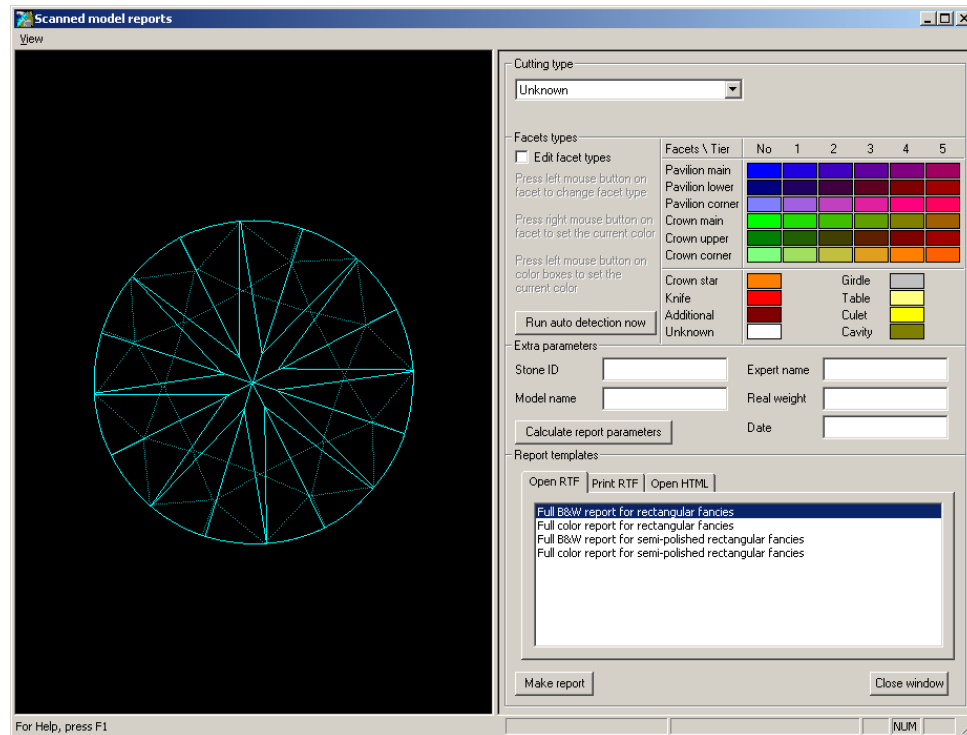



## Step 2. Set cutting type

Choose correct **Cutting type** in the drop-down list of cuttings:

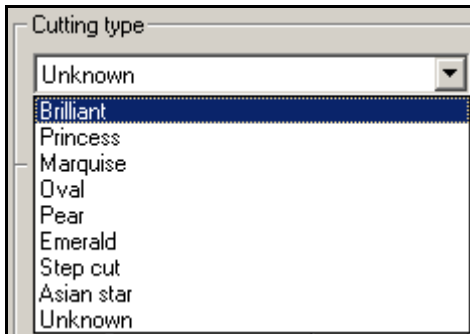

*Note.* There are different sets of report templates for different cuttings. The list on the bottom of the window will show templates available for the selected cutting:

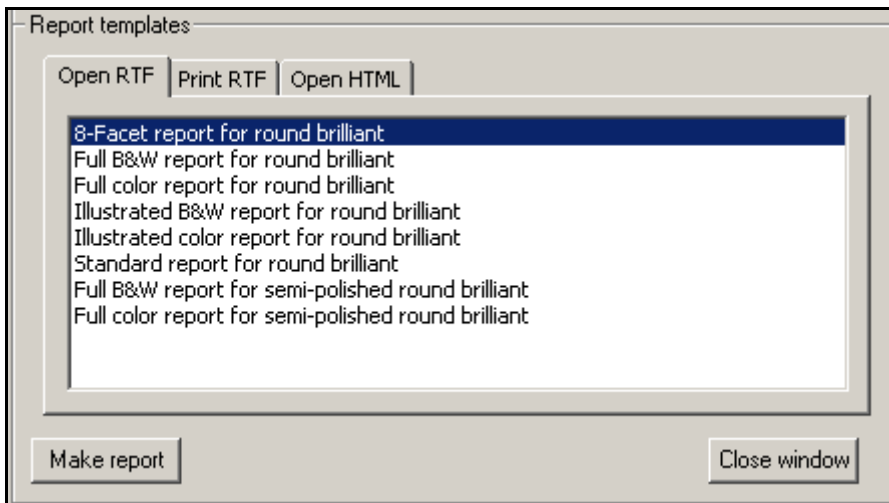

### Step 3. Specify facet types

1. Now you need to **specify types of each facet** so that the software will be able to calculate stone parameters. Check the checkbox **Edit facet types**. As it is the first time when you begin to edit facet types on this stone the DiamCalc will try to detect facet types automatically (the same is done when you press button **Run auto detection now**). The DiamCalc window will look similar to this.

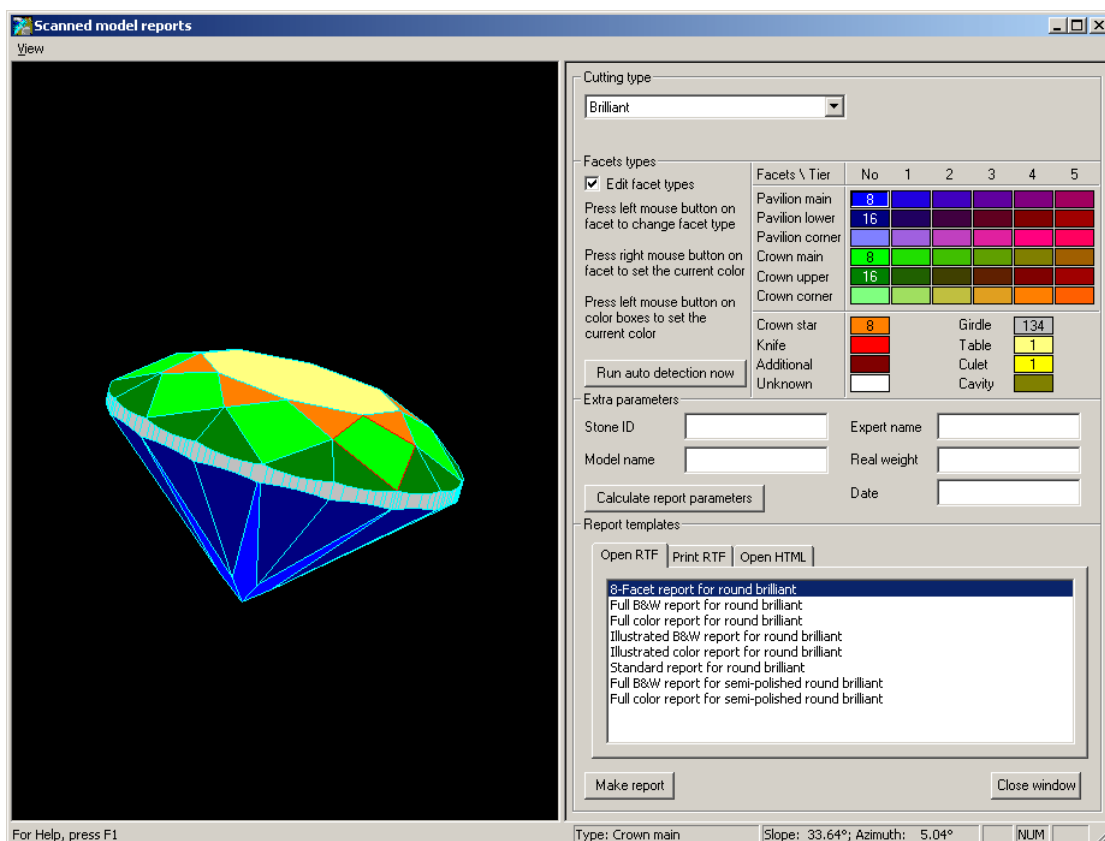

2. The current version of DiamCalc detects automatically types of all facets only for Round Brilliant cut. Processing of other cuts is not implemented yet and they are treated as semi-polished, i.e. only the basic facet types are detected (Main Crown, Main Pavilion, Girdle, Table, Culet). You will need to adjust types of other facets manually.
3. Verify that all facets are colored correctly and adjust colors where necessary. Refer to sample stones included with DiamCalc to see how different cuttings should be colored. Rotate the model to check all facets visually. Pay attention to numbers drawn above color boxes. They show the quantity of corresponding facets on the model. Make sure that there are no facets marked as Unknown. If you find it difficult to specify facet type mark it as Additional.
4. In the window with the model left mouse button rotates the model, right mouse button moves the model, mouse wheel changes zoom. When the mouse pointer hovers over the model facet you can see its type (if it is colored already) and angles of inclination in the status bar of the window.
5. If checkbox **Edit facet types** is checked you may select facet types in two ways and change types of facets on the model.



- To select facet type you may use the table of color boxes. Press left mouse button on the color box that represents the necessary facet type. It will become selected (it will be drawn sunken). Then press left mouse button on the model facet and its type and color will be changed to the currently selected.
  - On the other hand, you may choose the facet type by clicking right mouse button on the colored facet and the currently selected color box will switch to the color of this facet.
  - Color boxes in the table show the quantity of facets of the given type. It may be useful as a quick check, e.g. it is known that the full round brilliant cut should have 8 main facets and 16 halves.
6. Once all facets have correct types uncheck the checkbox **Edit facet types** to prevent accidental changes.
  7. Enter values for extra parameters that you need: Stone ID, Model name, Expert name, Real weight and Date.

#### **Step 4. Calculate report parameters**

1. Press button **Calculate report parameters**. DiamCalc measures stone parameters based on the Cutting type and facet types that you provided.
2. In order to see the result, choose tab with report type: **Open RTF**, **Print RTF**, **Open HTML**. The **Open RTF** and **Print RTF** options require MS Word installed to work correctly.



### 13.3 Customizing MS Word report templates

Several report templates in RTF format are included with the installation kit of the DiamCalc software. Files related to the report creation are placed in the **Report** subfolder of the folder where the DiamCalc software was installed. DiamCalc users may take these templates and customize them for their needs or create new templates.

#### Using RTF report templates

The RTF file defines the appearance of the generated report. The main idea is that the RTF file is a template for the report. During report creation DiamCalc software searches the RTF file for specific bookmarks and replaces them with parameter values. All available bookmarks are registered in the **Full report**. When you create the new one report you can use any available bookmarks from the **Full report**. The list of all bookmarks includes all parameters and pictures.

To see the list of all available bookmarks in a report RTF template file, to add and delete them you may use MS Word. Open RTF file in it. To see list with all available bookmarks in the template open window **Bookmark** from menu **Insert/Bookmark**:

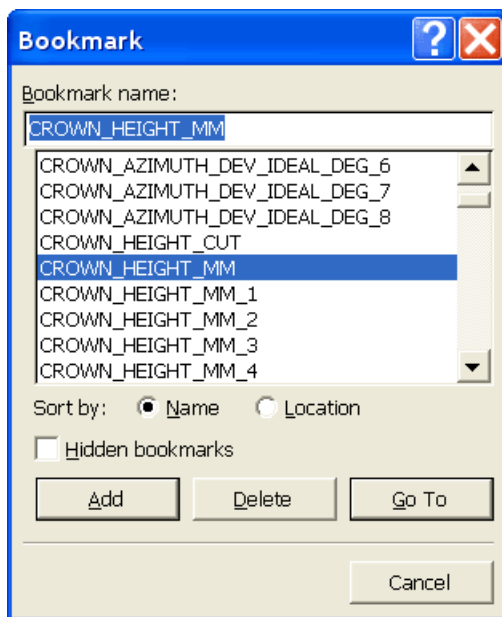

All *known* bookmarks will be replaced with the corresponding parameter values. All *unknown* bookmarks will be left intact. If some parameter value is not available, the corresponding bookmark will be left intact. If you don't want to see some parameter's value in the report, just remove the corresponding bookmark.

To find the bookmark you need to remove choose this bookmark from the list, mark it and press button **Go To**. The cursor will place to the position with obtained bookmark. Remove the bookmark.

To add a bookmark select the text, which will be later replaced with the parameter's value and choose from menu **Insert / Bookmark...** Write bookmark name and click button **Add**. The bookmark will be added to the list. Choose from menu **Tools /**

**Options**, select tab **View** and check the **Bookmarks** option in the section **Show**. All existing bookmarks will be shown as square brackets right in the document.

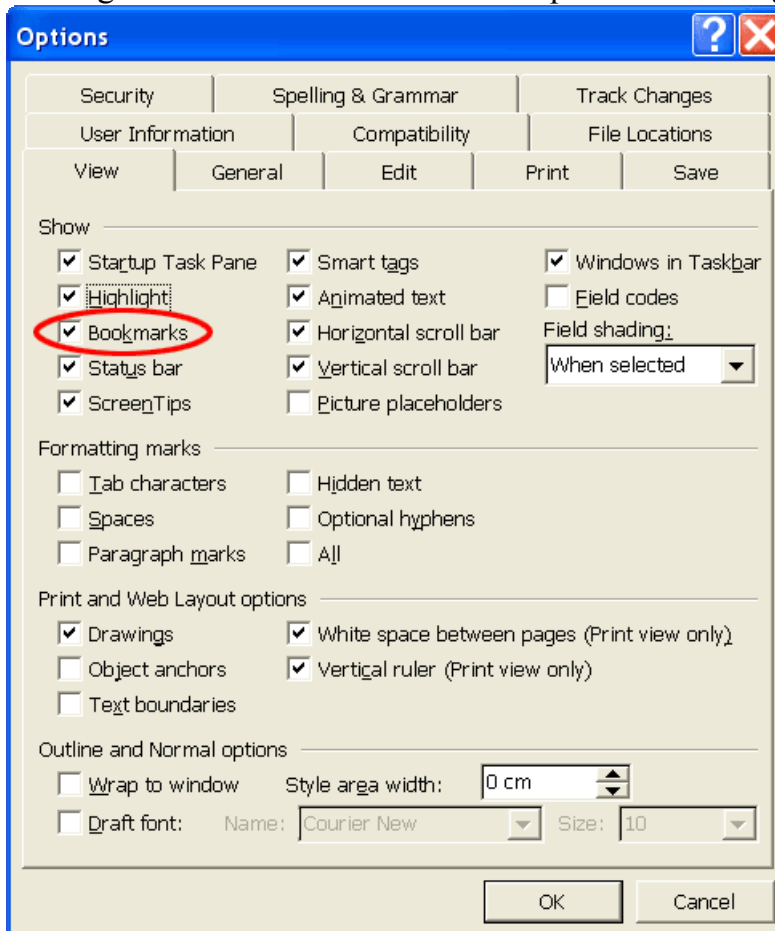

*Note.* All bookmarks in the DiamCalc RTF template file marked as N/A. It is easier to edit the report template when all bookmarks are visible.

Word does not allow editing of bookmark names once they are defined. You may delete the existing bookmark and create new. If you try to add a second bookmark with the same name, the first will be deleted.

For example, the text in the file marked with the bookmark **TOTAL\_DEPTH\_MM** will be replaced with the total height of the diamond in millimeters. Make sure that all bookmark names are written in capital letters. If it is necessary to put the same parameter's value several times in the report, you may use the following technique. RTF file can't contain two bookmarks with the same names, so add suffix **\_COPY\_N** to the primary bookmark's name, for example, **TOTAL\_DEPTH\_MM\_COPY\_1**. Thus, both bookmarks **TOTAL\_DEPTH\_MM** and **TOTAL\_DEPTH\_MM\_COPY\_1** will be replaced with the value of the same parameter - the total height of the diamond in millimeters.

Make sure that you save the changed file again in RTF format.

DiamCalc may generate a series of pictures for the report. In order to insert a picture in the report just add a corresponding bookmark to the desired place. It will be replaced by the picture during report creation. The size of picture in RTF report may be specified in MS Word. We usually create a table in the Word document and put the corresponding bookmark within its cell. Then disable the automatic resize of the table.

**Table properties** menu, **Options** button, clear check box **Automatically resize to fit contents**. Then specify the **Preferred width** for the column and **Specify height** for the row. Choose that the row height is exactly the desired value. With these settings the picture will be automatically scaled by MS Word during the creation of report.

#### **- Facets' heights**

N/A	N/A
Pavilion-and-crown-views-of-the-diamond-with-indication-of-facets'-heights-(mm)	
N/A	N/A
Pavilion-and-crown-views-of-the-diamond-with-indication-of-facets'-heights-(%)	
N/A	N/A
Pavilion-and-crown-views-of-the-diamond-with-indication-of-deviation-of-facets'-heights-from-the-average-values-(mm)	

If you allow automatic resize for the table or put the bookmark not in the table, the resulting picture will occupy the whole page.

## Using initialization files

The RTF template files should be described in the corresponding initialization files. Initialization files are plain-text files with the INI extension in the following format. INI file consists of sections. A section in the initialization file must have the following form:

```
[Section Name]
Key1 Name = string value1
Key2 Name = string value2
.....
```

### 13.4 Customizing printing and viewing DiamCalc reports

All available reports for polished diamonds are listed in the menu **Report** of the window **Scan polished diamond**. This menu has the following submenus: **Print Report**, **Open Report in MS Word**, **Export Report Data**.

The content of these submenus is updated dynamically. It depends on available report templates and the current cutting of the built model.

Helium software searches the **Reports** subfolder for the initialization INI files and looks through all such files. Initialization files related to printing reports for polished diamonds should have the following format.

```
[General]
ReportType=PolishRTF
VisibleName=<Submenu item name>
CuttingType=<Cutting type>
[FileNames]
TemplateRTF=<File name for the RTF template>
[Picture]
PictureID=POLISH_MODEL_REPORT
Bookmark=<MS Word bookmark name>
X=<Angle of rotation around X axis in degrees>
Y=<Angle of rotation around Y axis in degrees>
Z=<Angle of rotation around Z axis in degrees>
InvisibleEdges=<The way of drawing invisible edges >
```



```

VisibleSidesInColor=<The way of coloring of visible sides>
VisibleEdgesColorR=<The color of visible edges in RGB>
VisibleEdgesColorG=<The color of visible edges in RGB>
VisibleEdgesColorB=<The color of visible edges in RGB>
InvisibleEdgesColorR=<The color of invisible edges in RGB>
InvisibleEdgesColorG=<The color of invisible edges in RGB>
InvisibleEdgesColorB=<The color of invisible edges in RGB>
AspectRatioX=<Desired proportions of the picture>
AspectRatioY=<Desired proportions of the picture>

```

```

.....
[Picture<N>]
PictureID=POLISH_ANGLES_REPORT
Bookmark=<MS Word bookmark name>
PavilionView=<Pavilion (1) or crown (0) view of the stone>
PictureType=<The way of drawing picture>
Colored=<0 or 1>
FontSize=<Font size in percents>
AspectRatioX=<Desired proportions of the picture>
AspectRatioY=<Desired proportions of the picture>

```

```

.....
[Picture<N>]
PictureID=POLISH_SIDES_REPORT
Bookmark=<MS Word bookmark name>
Colored=<0 or 1>
PavilionView=<Pavilion (1) or crown (0) view of the stone>
PictureType=<The way of drawing picture>
Precision=<Number of digits after decimal point>
FontSize=<Font size in percents>
AspectRatioX=<Desired proportions of the picture>
AspectRatioY=<Desired proportions of the picture>

```

```

.....
[Picture<N>]
PictureID=PROFILE_VIEW_REPORT
Bookmark=<MS Word bookmark name>
Colored=<0 or 1>
FontSize=<Font size in percents>
AspectRatioX=<Desired proportions of the picture>
AspectRatioY=<Desired proportions of the picture>
TitleLengthGirdleFacet=<Title for Length Girdle Facet>
TitleDepthGirdleFacet=<Title for Depth Girdle Facet>

```

If value of the **CuttingType** key corresponds to the cutting type of the built model, an item will be added to the **Print Report** and **Open Report in MS Word** submenus. The **Print Report** command generates the report using the selected template, fills it with report parameters and pictures and sends it to the default printer immediately. The generated report will not be shown on screen. The **Open Report in MS Word** command fills the report template and opens it in the MS Word. It is possible to print the document or save it to file. Both of these commands require MS Word installed.

## Keys of the [General] and [FileNames] sections

These sections are mandatory.

**ReportType:** This key is mandatory. It should have the **PolishRTF** string for this type of report.

**VisibleName:** This key is mandatory. The value of this key will be shown in the **Print Report** and **Open Report in MS Word** submenus.

**CuttingType:** This key is mandatory. It identifies the cutting for which this report template is made. Different cuttings may have different set of parameters and different meaning of the same parameters. That is why it may be necessary to make report templates for each type of the cutting. Helium supports the following cutting types: **Brilliant** - for brilliant cut, **FancyRound** - for rounded fancies (marquise, oval and pear).

**TemplateRTF:** This key is mandatory. It should have the name of the source template file in the RTF format.

## [Picture] section

These sections are optional and specify the attributes of report pictures that require additional attributes. The number in the section name does not have a special meaning. It just enumerates sections. Helium software supports up to 50 sections of this type.

**PictureID:** This key is mandatory. It should contain the tag of the picture POLISH\_MODEL\_REPORT or POLISH\_ANGLES\_REPORT or POLISH\_SIDES\_REPORT or PROFILE\_VIEW\_REPORT written in capital letters.

The picture with the POLISH\_MODEL\_REPORT tag contains a simple model of the polished diamond without inscriptions above it. Picture attributes allow to specify whether to draw invisible edges or not, orientation of the model, color and aspect ration of the picture.

The picture with the POLISH\_ANGLES\_REPORT tag contains a model of the polished diamond with facet angles inscribed above the model. Picture attributes allow to specify the orientation of the model, what angles to write, font size, aspect ratio and color of the picture.

The picture with the POLISH\_SIDES\_REPORT tag contains a model of the semi-polished diamond with information about all facets inscribed above the model. Picture attributes allow to specify the orientation of the model, what information to write (angles / heights), precision, font size, aspect ratio and color of the picture.

The picture with the PROFILE\_VIEW\_REPORT tag contains a side view of the model of the polished diamond with the values of basic parameters inscribed above the model. Picture attributes allow to specify the font size, aspect ratio and color of the picture.

**Bookmark:** This key is mandatory. It should contain the name of the MS Word bookmark in the RTF template for the picture. All bookmarks should be written in capital letters. During the report generation this bookmark will be replaced with the picture.

**X, Y, Z:** These keys are optional. If such key is not specified it is assumed to be zero. It is the angle of rotation of the 3D model around X, Y, Z axis in degrees before making the final image. This attribute allows to create various views of the same model.



**InvisibleEdges:** This key is optional. It specifies the way of drawing invisible edges of the 3D model. Possible values are: 0 - invisible edges are not drawn, 1 - invisible edges are drawn without refraction, 2 - invisible edges are drawn taking refraction of the light into consideration. If this key is not specified it is assumed to be equal to 1.

**VisibleSidesInColor:** This key is optional. It specifies the way of coloring of visible edges. Possible values are: 0 - black and white scheme (for example, extra facets will be drawn in gray color), 1 - color scheme (for example, extra facets will be drawn in blue color). If this key is not specified it is assumed to be equal to 0.

**VisibleEdgesColorR, VisibleEdgesColorG, VisibleEdgesColorB:** These keys are optional. If such key is not specified it is assumed to be zero. They specify the RGB color for drawing visible edges of the 3D model.

**InvisibleEdgesColorR, InvisibleEdgesColorG, InvisibleEdgesColorB:** These keys are optional. If such key is not specified it is assumed to be zero. They specify the RGB color for drawing invisible edges of the 3D model.

**AspectRatioX, AspectRatioY:** These keys are optional. If such key is not specified it is assumed to be zero. They specify the desired proportions of the generated picture. If the actual proportions of the picture differ from the specified, blank margins are added.

**PavilionView:** This key specifies the orientation of the model. Possible values are: 0 - crown view, 1 - pavilion view. If this key is not specified it is assumed to be equal to 1.

**PictureType:** This key specifies the way of drawing the picture. Possible values for this parameter are: 0 - invisible edges are drawn taking refraction into account, slope angles of main facets are written near facets; 1 - invisible edges are not drawn, slope angles of all facets are written; 2 - invisible edges are not drawn, azimuth angles of all facets are written; 3 - invisible edges are not drawn, deviation of slope angles from the average are written; 4 - invisible edges are not drawn, deviation of azimuth angles from ideal are written; 5 - invisible edges are not drawn, slope angles of main facets are written near facets together with the maximum inscribed circle and section of the model with the plane in which the circle lies; 6 - invisible edges are not drawn, slope angles of main facets are written above facets together with the maximum inscribed circle and section of the model with the plane in which the circle lies. If PictureID is POLISH\_SIDES\_REPORT then possible values for this parameter are: 0 - slope angles of all facets are drawn; 1 - azimuth angles of all facets are drawn; 2 - heights in % of all facets are drawn; 3 - heights in mm of all facets are drawn.

**Colored:** This key is optional. Default value: 0. The program generates black and white pictures if it is 0 and colored otherwise.

**FontSize:** This key is optional. Default value: 100. This parameter adjusts the font height on the picture. It specifies the ratio between desired and default font size. For example, if FontSize=200, all text on the picture will be twice higher than default.

**Precision:** This key is optional. Default value: 2. This parameter is applicable to pictures with PictureID=POLISH\_SIDES\_REPORT. It specifies the number of decimal digits used when writing facet angles or heights.

**TitleLengthGirdleFacet, TitleDepthGirdleFacet:** These keys are optional. They specify the text that will be written on the picture above the corresponding parameter values. When the font size is large the default text may appear too big to fit the picture and you may want to change it.

## 14 Diamond Calculator FAQ

### **14.1 I can not make a change of 1/10 degree while modifying ASCII file. Is there a way to refine the change?**

You may enter the desired value directly. Press Enter to apply the changes.

### **14.2 How do I place a movie recorded by the DiamCalc on a web site?**

The DiamCalc allows exporting of the generated movies into common AVI and QuickTime format. Moreover, during export you may choose the desired codec from the list of codecs installed in your system for encoding your movie. Thus you may share your movies with everyone through your web site. If you want the movie to play directly on your web-page without explicit download of the file you may convert AVI file into animated GIF format with third-party programs. In this case we recommend saving the source AVI file without compression to avoid artifacts caused by loss compression.

### **14.3 How can I make fancy color photorealistic pictures with DiamCalc?**

The DiamCalc allows to select from two predefined colors (choose menu item **Gem material / Standard types**), but you may enter arbitrary absorption spectrum (**Gem material / View / Modify properties**). In the **Gem properties** on the **General** tab click the **Add** button. This will add an **Absorption** tab that allows to specify the absorption spectrum. You need to know absorption characteristics of your stone to get accurate results.

### **14.4 What is spread?**

The spread is parameter showing the difference between the weight of the given diamond and the weight of the *standard diamond*. The standard diamond has the same area as the given diamond but Tolkowsky proportions with the medium girdle thickness. The spread parameter tells you if your diamond looks more or less massive than it really is. The spread parameter also works with fancy shapes comparing them with round standard diamond. The spread indication is available only in the registered version.

### **14.5 What is AGS spread?**

$$NW = C (6.47 / D)^3$$

**C** - weight of diamond (ct)

**D** - diameter of diamond (mm)

**6.47** - diameter in mm of diamond with weight 1 ct and Tolkowsky proportions

### **14.6 What is gamma correction?**

As human eye perception of the brightness is not linear with the light intensity (in fact, it is close to **Gamma function**) the modern monitors use the nonlinear pixel brightness to compensate this behavior and let the human to see computer colors having uniform brightness. For the most monitors the factor of that compensation (gamma) is about 2. For this case gamma correction in the DiamCalc should be 0.5. However, it may differ for different monitors (particularly it depends on the monitor's control settings and settings of the video adapter driver), so you may adjust this parameter in the DiamCalc. We are planning to add a utility letting the user to define and adjust this value looking at test pictures in the future.

### **14.7 What is the accuracy of the DiamCalc mass estimation?**

For convex shapes it is completely accurate. However, you should mention the following things:

- In order to estimate the stone weight correctly you have to know the exact value of specific gravity of the gem material.
- The real stone always slightly differ from the model that was used for cutting because accuracy of cutting process is limited (another reason - the real stone can have extra facets or omitted facets especially on the girdle).

If you have suspicions about specific file then you may send to us this file and your suspicions and we will analyze it.

### **14.8 Why does the DiamCalc valley girdle measurement produce negative values for very thin and extremely thin girdles, which does not match any charts?**

The charts usually contain bezel girdle measurement and DiamCalc takes it for a basis, while valley girdle measurement is calculated using mathematical model of the brilliant cut. An average stone with regular brilliant proportions has a valley girdle about 1.6-1.7 less than bezel girdle. Of course, the real stone can't have negative measurements, but DiamCalc doesn't discard negative results of computations in order not to lose information (to indicate how really thin it is).

### **14.9 How to open GemCad GEM files in DiamCalc?**

Unfortunately, the format of the GemCad GEM files is not open, but you can load them in GemCad and then save in ASCII format. To import GemCad ASCII files use menu command **Cut / Import cut / From GemCad ASC file**.



#### ***14.10 How can I contact the DiamCalc support?***

If you have any problems with the DiamCalc or have any suggestions for its improvements you may always send a message from our web-site:

<http://www.octonus.com/oct/support/SubmitTicket.phtml>



## 15 DiamCalc versions history

### 15.1 DiamCalc 3.0 - August 3, 2007

#### 1. New features in the photorealistic rendering mode

- Light bloom or flare effect
- Lighting with external high dynamic range panorama (HDR)
- Lighting with generated panorama (zones and light sources)
- Paper sheet environment
- Observer model

#### Bloom effect

The bloom or flare effect produces fringes of light around very bright objects in an image, as stressed by the red squares in the actual rendering screenshot below:

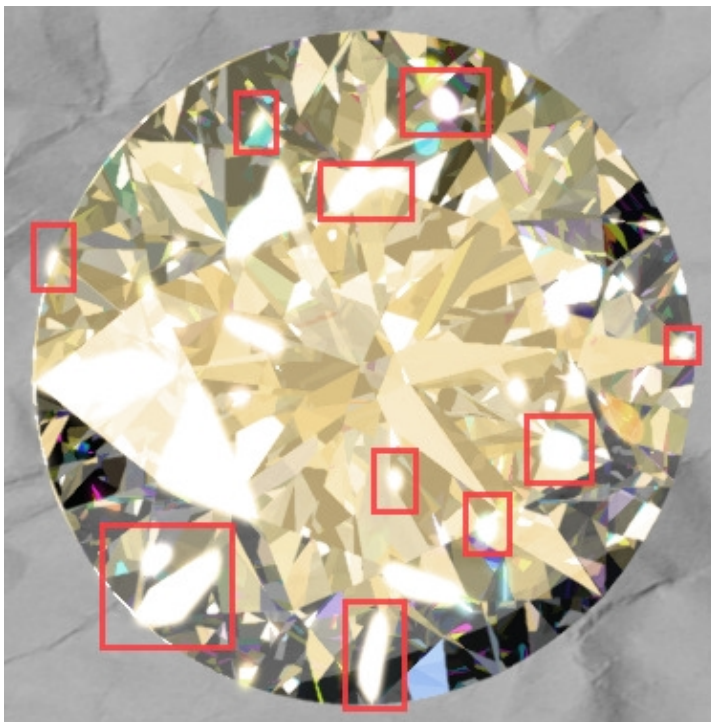

The physical basis of bloom is that lenses (including those in our eyes) can never focus perfectly in the real world. Under normal circumstances, these focus imperfections are not noticeable, but an intensely bright light source will cause the imperfections to become visible. As a result, the image of the bright light appears to spread (bleeds) beyond its actual borders.

Depending on the background colour or shade, the bloom can appear to extend outside the edges of the diamond.

#### Lighting panorama with high dynamic range (HDR)







A lighting environment can be defined by a high dynamic range panorama (also referred to as HDR panorama). Luminance or radiance observed in the real world can usually be stored in special high dynamic range images that correspond to actual physical values. This additional information makes high dynamic range images that are different to traditional digital images that may appear on a monitor or on a paper print. For example in the photo image above the bright parts of the sky radiate much more light than is seen in a regular photograph, and such intense light sources can create a bloom or flare in a gemstone.

### Lighting with generated panorama (zones and light sources)

Panoramas with different light sources can be generated by specifying the size and quantity of light sources.

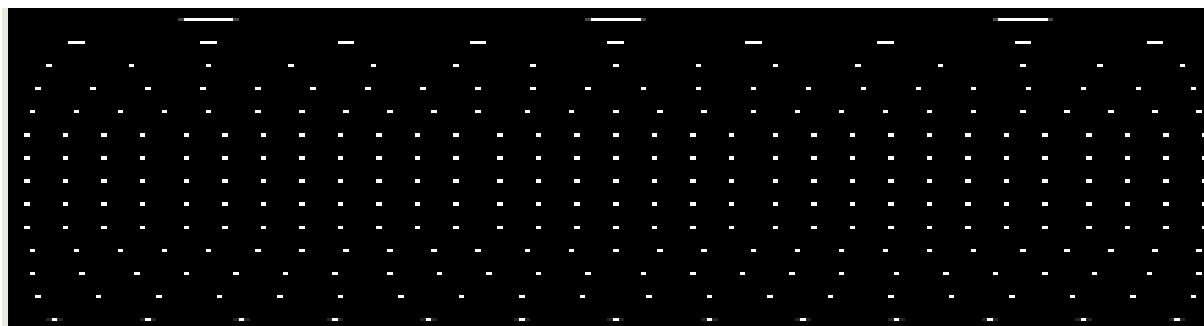

Panoramas with colored zones (up to 8 zones) can also be generated.

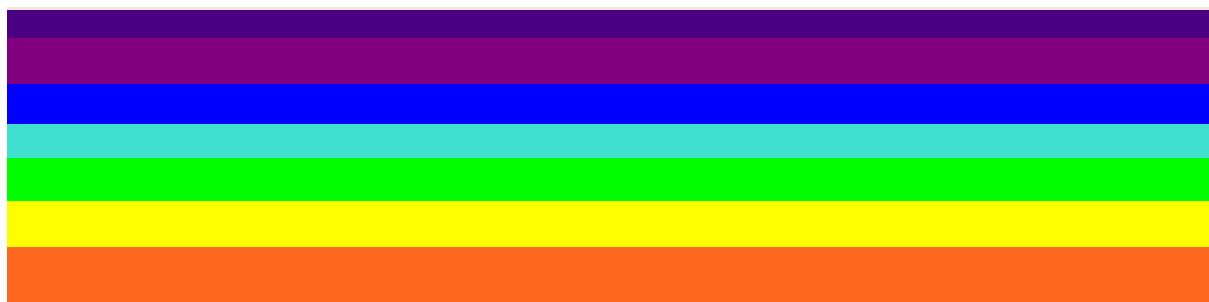

A panorama for the «Office» lighting environment can also be generated.

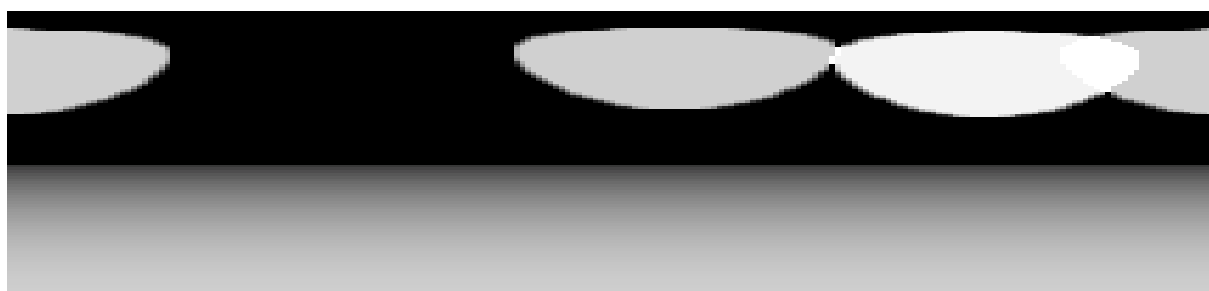

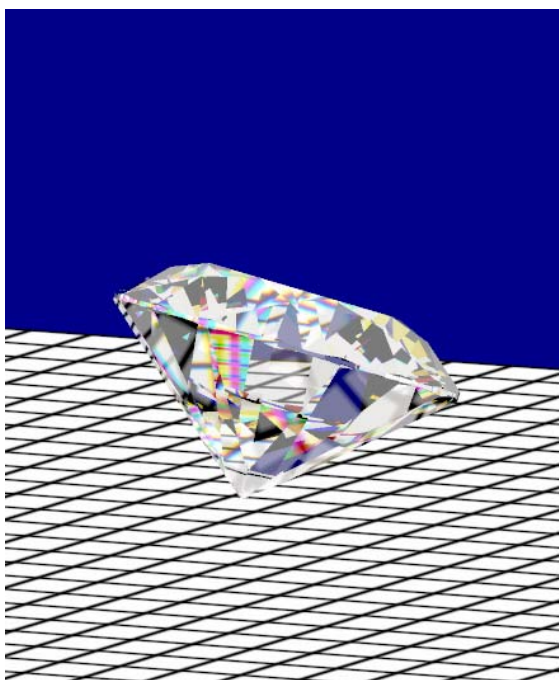

### Paper sheet environment

A paper sheet can be rendered either using an external texture or one that is generated in a grid-style. In the latter case, you can customize grid settings, paper color, size and other options.

### Observer model

DiamCalc 3.0 supports a 2D observer model. The observer model consists of two parts: the observer head and the observer body. This observer model design allows simulation of a head inclined above a gem being observed. You can set up the observer height, eye position, shoulder position, head incline angle and mask parameters.

## 2. ETAS images

Additional features in new version of DiamCalc include ETAS images (effective total angular size) which at a glance give a good indication of where a diamond can gather light that creates brightness and sparkle. The image on the left shows an ETAS images from the diamonds perspective overlain on the HDR image of the observer placed inside a ballroom. The image on the right is a DETAS image for an emerald cut that shows the dynamic probability to see a sparkle as the diamond is rocked through a small range of north south motion.

ETAS is the basic functional tool for the quantification of the basic light performance responses calculated by DiamCalc3. But DiamCalc3 takes this a further stage by computing for two eyes and other observer specific variables such as pupil size and viewing distance. Dynamic ETAS (DETAS) is a metric for quantification of scintillation.



## 3. Cut Designer tool builds variable models

For companies active in designing special cuts such as many Sightholders, Tiffany and Swarovski, the new cut designer tool enables the creation of parametric models with tied proportions; each and parameters can be varied. This overcomes a problem in previous computer aided design software that required the laborious creation of separate models for every new proportion set.

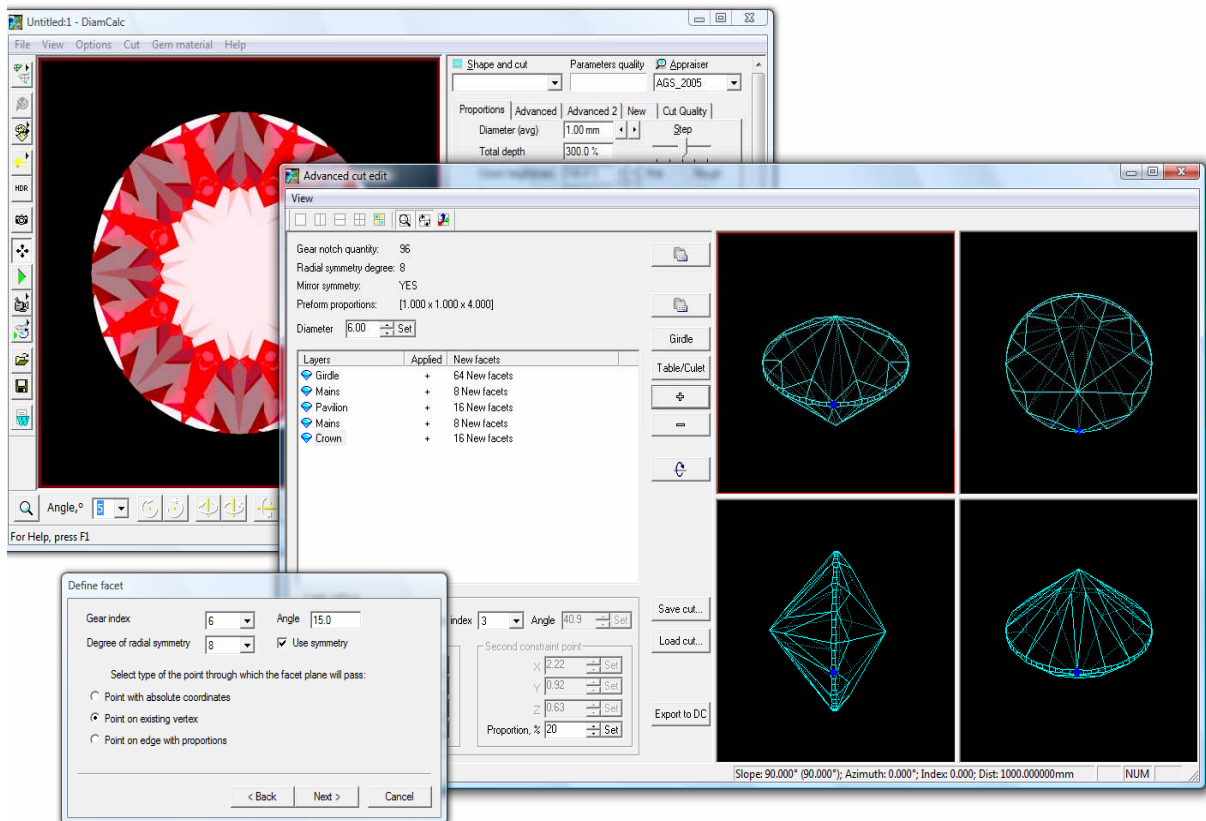

#### 4. Simulation algorithm for stereoscopic photorealistic view of diamond is improved

Algorithm used in simulation of stereoscopic photorealistic view of diamond has been found incorrect in some cases (this algorithm is implemented when "Observer\Head and eyes\Brain picture\Smart bright" option is selected and also when "Light return stereo" Cut Quality index is computed). So the computation was redesigned and the photorealistic image in the mentioned mode and "Light return stereo" index values will differ from those obtained in older versions.

## 5. Added Natural Diamond and Cubic Zirconia to the list of materials for setting refraction in Gem properties

Open panel Gem properties from menu Gem Material -> View / Modify properties... Press button Select from list... The panel Gem material list will open. Where you can find new materials.

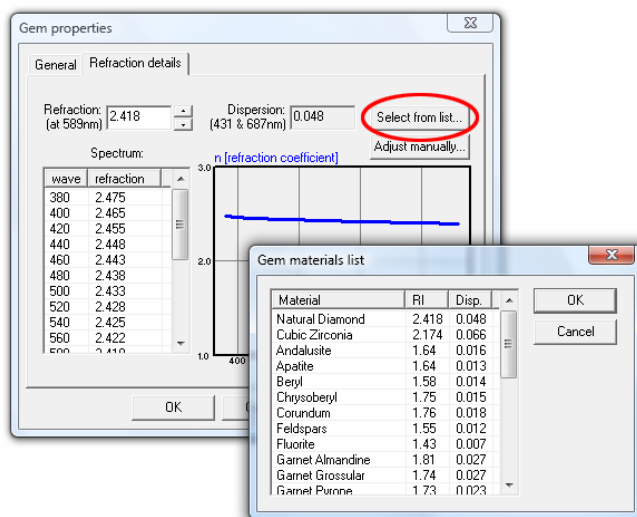

## 6. Added the new GIA appraiser for Brilliant cut. It is named GIA\_PCT\_2006

This appraiser provides estimation of the overall cut quality, using several cut parameters simultaneously, namely Pavilion, Crown and Table. The parameters that are taken into account during stone appraisal are displayed in gray, red or green color. The red color means that it is necessary to decrease the parameter value to get to a better group, the green color suggests to increase the parameter value. There is also a special button «Better group» that changes all parameters of the stone to move it to a nearest better group. Organization of this appraiser is similar to AGS\_2005.

## 15.2 DiamCalc 2.8.0 (build 375) - September 11, 2006

- Added the possibility to generate same RTF and HTML reports for scanned polished diamonds as in the [OctoNus Helium Polish](#) software. Users may customize report templates to fit their needs. Such reports may be generated using files with 3D model of the stone obtained by OctoNus scanners as well as using any other imported 3D model. There are examples of new DiamCalc reports for Helium and Sarin scanned polished brilliants:

Sample scanned by Helium Polish	 <a href="#">HTML report for polished brilliant (Helium)</a>	 <a href="#">MS Word Illustrated report for polished brilliant (Helium)</a>	 <a href="#">PDF</a>
Sample scanned by Sarin	 <a href="#">HTML report for polished brilliant (Sarin)</a>	 <a href="#">MS Word Illustrated report for polished brilliant (Sarin)</a>	 <a href="#">PDF</a>

### [More samples of the reports](#)

- The OctoNus Helium software can export a 3D model of the scanned diamond and its parameters to the DiamCalc's DMC file. DiamCalc can read such files and display the scanned model and its parameters. DiamCalc can generate the same reports on scanned diamond as [Helium Polish](#) does using the data provided by the Helium Polish. If the loaded file contains the scanned diamond parameters, some of them will be displayed on the "Advanced" and "Advanced 2" tabs:

Proportions	Advanced	Advanced 2	Proportions	Advanced	Advanced 2
Diameter (min)		4.76 mm	Crown angle(avg)		32.23 °
Diameter (max)		4.79 mm	Crown angle(min)		31.06 °
Total height		56.9 %	Crown angle(max)		32.53 °
Crown height(avg)		11.5 %	Pavilion angle(avg)		40.63 °
Pavilion height(avg)		42.7 %	Pavilion angle(min)		39.64 °
Girdle bezel(avg)		2.9 %	Pavilion angle(max)		41.48 °
Girdle bone(avg)		3.3 %	Upper angle(avg)		39.83 °
Girdle valley(avg)		1.6 %	Star angle(avg)		18.84 °
Table (avg)		64.0 %	Halves angle(avg)		41.52 °
Culet (avg)		0.6 %	Twist (avg)		1.26 °

- When you work with scanned or imported 3D model a special button «Scanned reports» becomes enabled. This button is located to the right of parameters list. It invokes a new window that allows creating reports for 3D models of diamonds obtained by OctoNus scanners as well as for any other imported 3D model. The DiamCalc installation contains a set of sample stones with different cuttings scanned on Helium. They are placed in the SAMPLE\_STONES subfolder.

4. If you loaded the DMC file that was created by Helium, the window for reports will look similar to this:

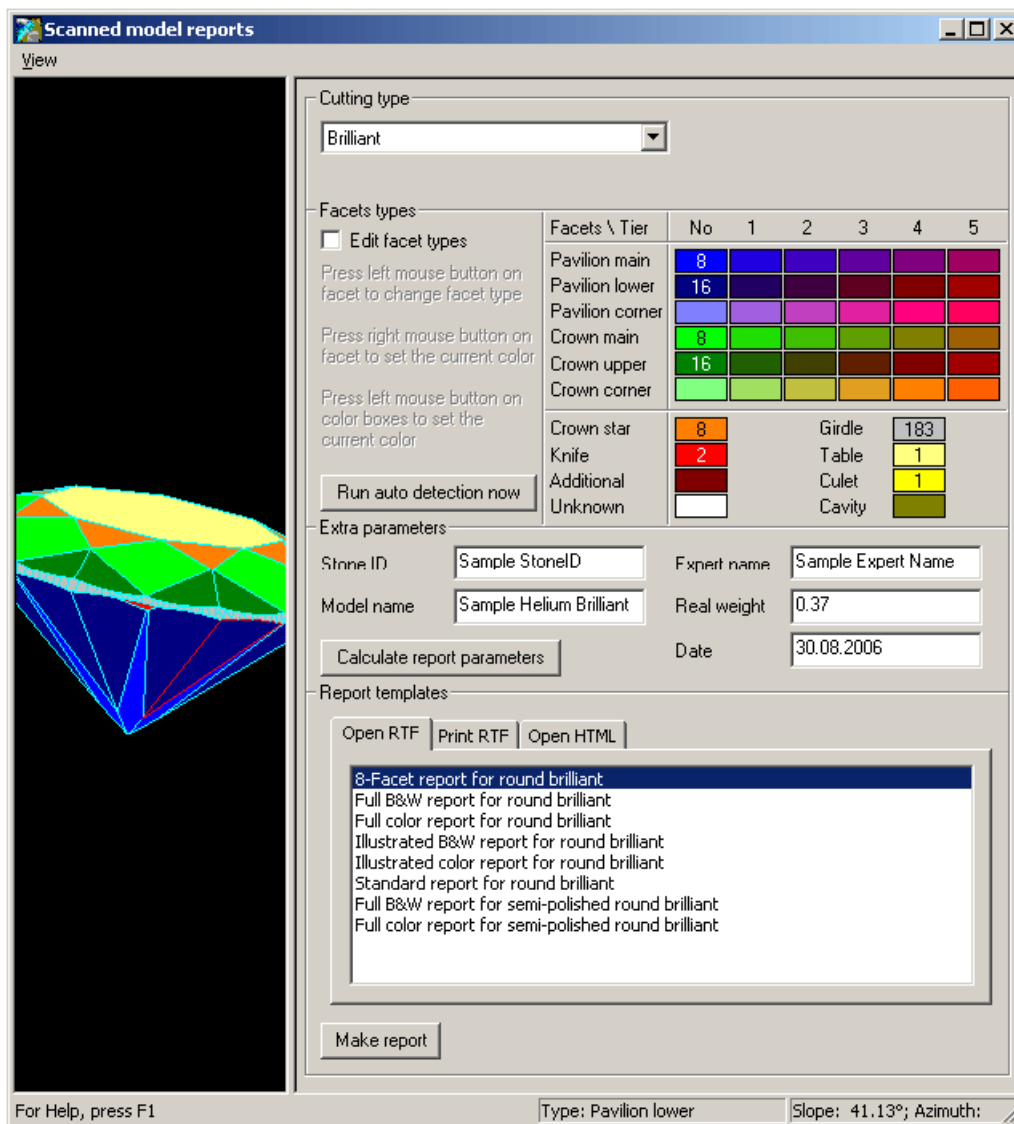

5. The cutting type of the model is already defined; all facets of the model are colored according to their types. Generally you will not need to alter these. You may adjust extra parameters like "Model name". In order to make a report choose report template from the list and press the "Make report" button. RTF reports require MS Word to be installed. If you choose report from "Open RTF" tab the DiamCalc will fill the chosen template with report parameters and pictures and launch MS Word. If you choose report from "Print RTF" tab the filled report will be sent to default printer and MS Word will close. Reports from "Open HTML" tab will be shown in your default browser.
6. If you imported 3D model or loaded DMC file that doesn't have report data yet, the window for reports will look similar to this:

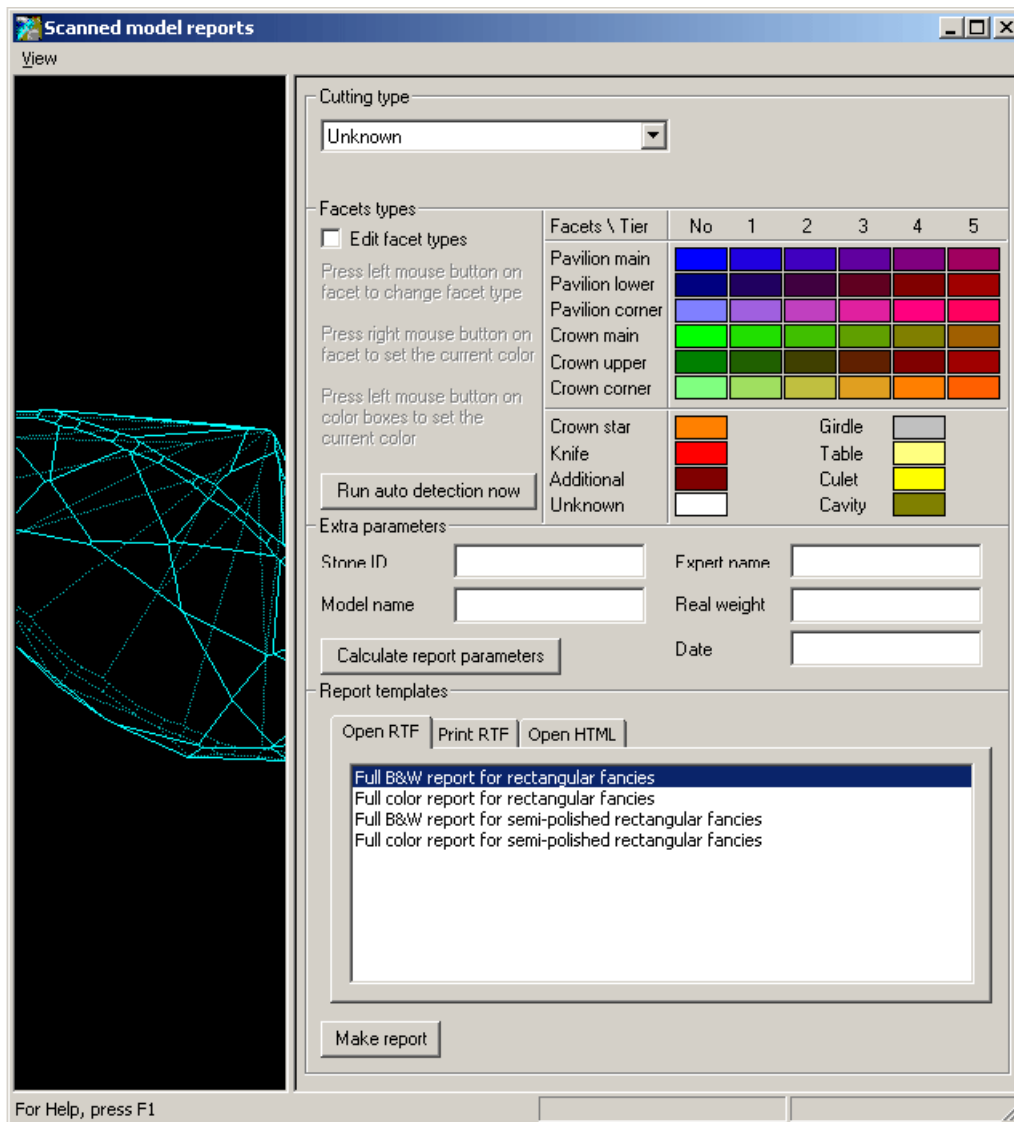

7. At first specify correct cutting using drop-down list. Please note, that there are different sets of report templates for different cuttings. The list on the screen will show templates available for the selected cutting. Then you will need to specify types of each facet so that the software will be able to calculate stone parameters. Check the "Edit facet types" checkbox. If it is the first time when you begin to edit facet types on this stone the DiamCalc will try to detect facet types automatically (the same is done when you press the "Run auto detection now" button). Verify that all facets are colored correctly and adjust colors where necessary. Refer to sample stones included with DiamCalc to see how different cuttings should be colored.
8. In the window with the model left mouse button rotates the model, right mouse button moves the model, mouse wheel changes zoom. In the edit mode (when "Edit facet types" is checked) use the table of colors to choose the facet type. Press left mouse button on the facet and its type will be changed to the currently selected. Press right mouse button on the facet and the currently selected color will switch to the color of this facet. Color boxes in the table show the quantity





- of facets of the given type. It may be useful as a quick check, e.g. it is known that the full round brilliant cut should have 8 main facets and 16 halves.
9. Once you specified types of all facets enter values for extra parameters that you need and press "Calculate report parameters button". DiamCalc will measure stone parameters based on the Cutting type and facet types that you provided. In order to see the result, choose report template from the list and press the "Make report" button.
  10. For more detailed step-by-step instruction of making report for a model obtained by Sarin scanner click [here](#)
  11. The DiamCalc installation contains a set of report templates for different cuttings. They are placed in the REPORTS subfolder. You may customize provided RTF report templates in MS Word or create your own taking existing templates as examples. Please note, that MS Word report templates should be saved in RTF format. HTML report templates also may be customized. Use your favorite HTML editor for it. The examples of how the MS Word "Illustrated color report for round brilliant" looks like are in the beginning of the section.
  12. The Pavilion and observer (dark zone body) lighting was added.

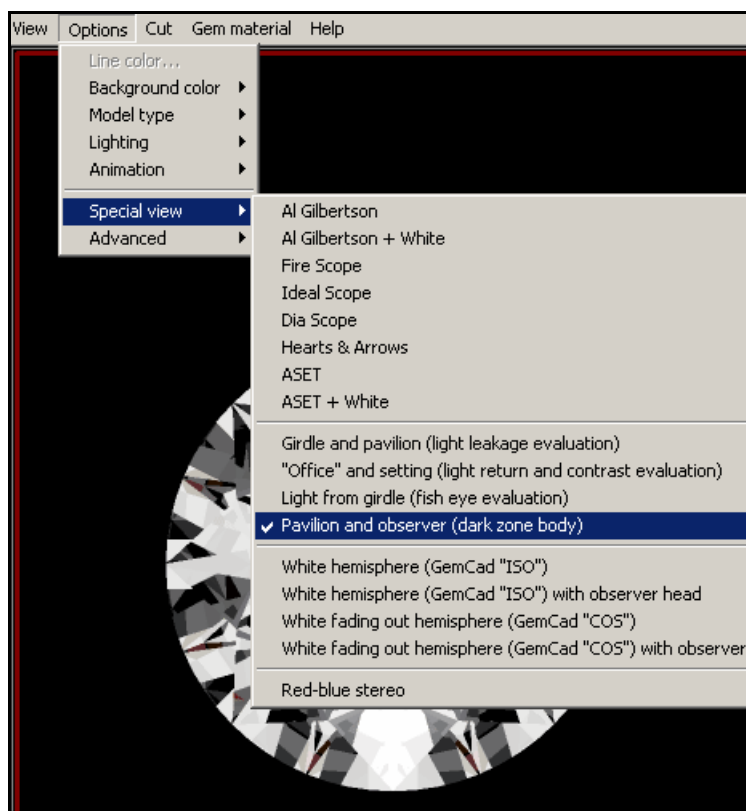

13. The Cut Quality estimation has new index: Dark zone mono. Calculation of Contrast is disabled.
14. The new "Princess 3-chevron" cut was added.

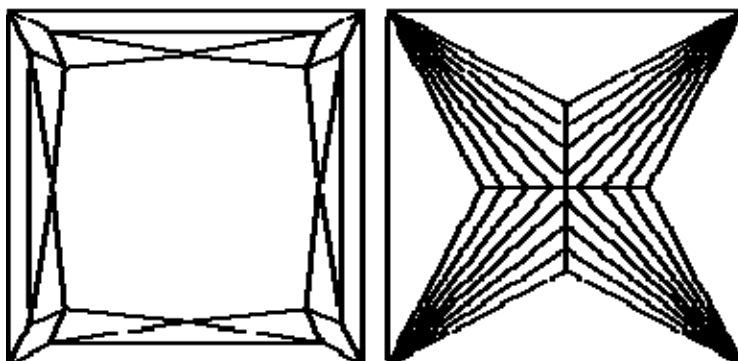

15. The Radiant cut was corrected. It allows significant stretching now.

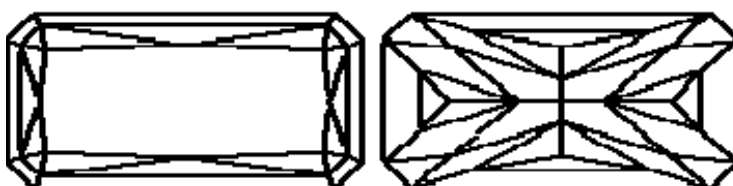

16. Support for [external cuts](#) from DLL was added. All DLLs implementing such cuts should be placed in the "Cuttings" subfolder of DiamCalc. The content of this folder is analyzed at the start of the program and all found cuts are appended to the list of available cuts. If you save DMC file with external cut and pass it to another user of DiamCalc or GemAdviser, make sure that the recipient also has the corresponding DLL.
17. AGS Angular Spectrum Evaluation Tool + White lighting (ASET white) is added. It has the same settings as ASET lighting, and has one additional diffuse white light source.

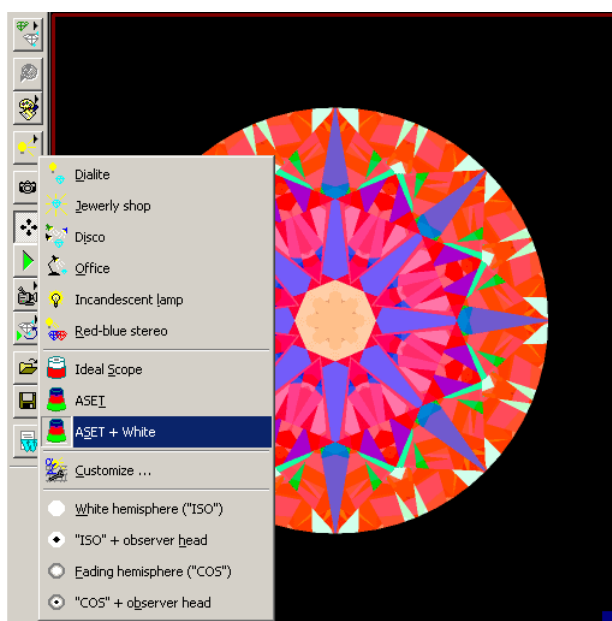

18. The IdealScope lighting settings are corrected. Now the light source that represents diffuse light (infinite plane) allows to specify fading of the light at infinity. See lighting configuration dialog box. The diffuse light source that is

used in IdealScope and ASET+White lightings has a new parameter: Source brightness at infinity. If this parameter is 100% then light brightness at infinity is the same as in the center and the light source becomes identical to its previous version.

19. Added possibility to view color information of any point of the model's photoreal image. Choose menu item View -> Color information and click right mouse button on image to get color information. The popup window will contain detailed information which is updated by the right-click on the model.

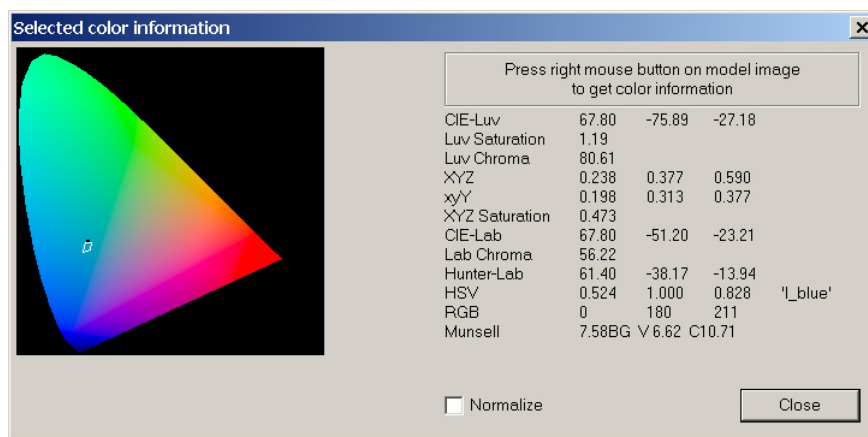

20. Added possibility to ignore material dispersion. See Simulation Parameters in dialog box for customizing lighting options (Menu Options -> Lighting -> Customize).
21. Added possibility to change ray tracing accuracy when rendering photoreal images. See Simulation Parameters in dialog box for customizing lighting options (Menu Options -> Lighting -> Customize). The following lightings use three ray (RGB) tracing by default: Al Gilbertson, Al Gilbertson + White, Fire Scope, Ideal Scope, Dia Scope, Hearts & Arrows, ASET, ASET+White, GemCad ISO, GemCad ISO+head, GemCad COS, GemCad COS+head.
22. Added "Lower facets length" parameter to Brilliant cut to measure [lower girdle facets](#) according to GIA and Sarin.
23. Added possibility to multiply absorption spectrum by value. See Gem material -> View/Modify properties dialog box, "Absorption" tab.
24. Added possibility to adjust absorption spectrum baseline. See Gem material -> View/Modify properties dialog box, "Absorption" tab.
25. Added possibility to import transmission spectrum of gem material from text files. See Gem material -> View/Modify properties dialog box. The file with transmission spectrum should have two columns of values separated by spaces. The first column should contain wavelength, the second column should contain transmission coefficients for each wavelength. Besides this file it is necessary to indicate plate thickness and material for recalculation of transmission coefficients into absorption coefficients.
26. Added possibility to import absorption spectrum of gem material from text files. See Gem material -> View/Modify properties dialog box. The file with absorption spectrum should have two columns of values separated by spaces.



The first column should contain wavelength, the second column should contain absorption coefficients for each wavelength.

27. It is possible to set position of the light sources with the precision of 1 degree.
28. Added possibility to import convex models in binary and ASCII stereolithography format (STL). See Cut → Import cut menu. Non-convex models will be imported as convex hulls.
29. Added possibility to import AutoDesk DXF, GemCad ASCII, Stereolithography STL, Sarin SRN files via drag-and-drop operation.
30. Added possibility to load gem material from DMC file. See Gem material → Load material menu.
31. Added possibility to export absorption spectrum of gem material into text file. See Gem material → View\Modify properties dialog box.

### 15.3 DiamCalc 2.4.0 (build 337) - September 30, 2005

This is a nonscheduled beta version devoted to the new AGS\_2005 appraiser. The goal of this version is to help the gem cutters to determine the final grade of the cut. As AGS\_2005 takes into consideration several parameters simultaneously together with the Girdle Height and Spread determining the overall grade is not an easy task.

This version is not a final release, but only a beta, because the rules of the new AGS 2005 appraiser may still be corrected.

1. The Brilliant cut has new parameters: Culet offset and azimuth, Upper and lower facets azimuth.
2. The previous AGS appraiser is renamed to AGS\_Classic.
3. The new AGS appraiser for Brilliant and Prince cuts is added. It is named AGS\_2005. This appraiser provides estimation of the overall cut quality, using several cut parameters simultaneously. The parameters that are taken into account during stone appraisal are displayed in gray, red or green color. The red color means that it is necessary to decrease the parameter value to get to a better group, the green color suggests to increase the parameter value. There is also a special button "Better group" that changes all parameters of the stone to move it to a nearest better group.

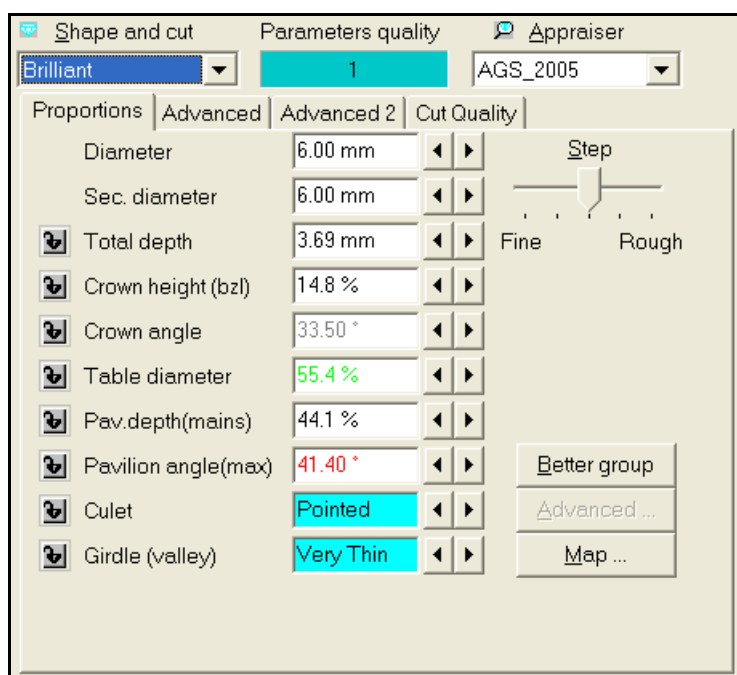

4. AGS Spread parameter is available. It is used in AGS\_2005 appraiser.

5. AGS Angular Spectrum Evaluation Tool lighting (ASET) is added.

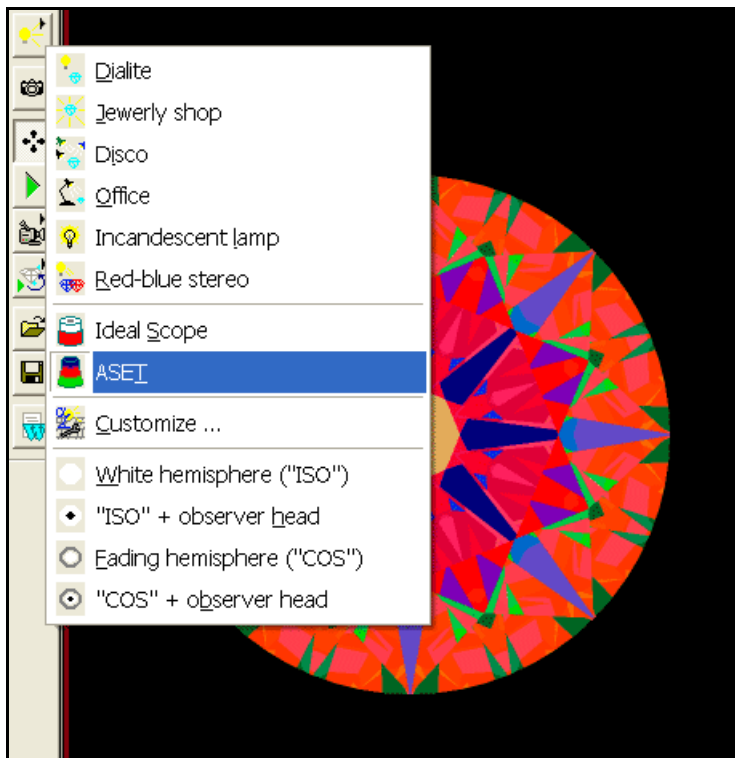

6. The possibility to choose the RGB primaries for color correction is available. See Gamma correction section in the lighting configuration.

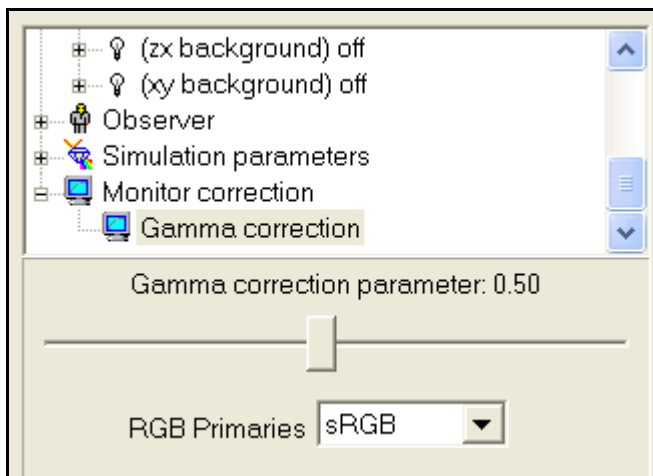

## 15.4 DiamCalc 2.3.0 (build 321) - April 20, 2004

### New features

1. BLR calculation is allowed for non-round cuts. The table's area is taken into account
2. The algorithm for calculation of photorealistic images is changed. It takes into consideration now the changes in the angle of divergence of non-parallel beams during refraction
3. The calculation of Leakage mono and Leakage Stereo in Cut Quality estimation was disabled. We have calculated integral leakage value before. It was not correct, because weak leakage does not make Brilliance worse (see the plot below). But the weak leakage over large area may give the same integral coefficient as a strong leakage over small area. That is why it is necessary to change the approach to leakage estimation. We have not found the new correct formula yet

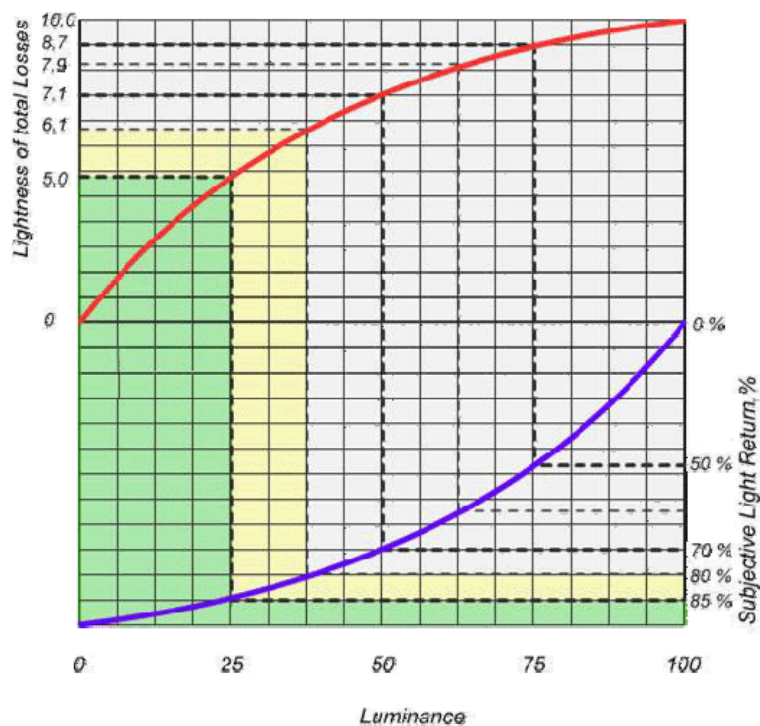

4. Added possibility to edit imported convex cuts of any format, not only GemCad ASCII. Implemented parameters: average diameter; crown, pavilion heights; distance between crown and pavilion; culet and table offsets in horizontal plane. Non-convex cut are imported, but without the possibility of editing. It is allowed to create an editable convex hull during import of non-convex model. Press button **Advanced** in the parameters panel to open the new window. This button becomes available after import of some cut. Advanced editing of the





convex imported cuts allows adjusting the position of any facet. The new GUI of advanced editing allows viewing the model from up to four views with arbitrary zoom and displacement. Use left mouse button to rotate the model, right mouse button to move the model and mouse wheel to change zoom. For more detailed description of the new window see the "Adjusting shape of arbitrary imported 3D model of the diamond" section in the manual

5. The OctoNus Helium software can now export model of the scanned diamond and its parameters to DiamCalc DMC file. DiamCalc can read such files and display the scanned model and its parameters. DiamCalc can generate the same reports on scanned diamond as Helium does using the data provided by the Helium. For more information about Helium please visit [Helium system page](#). For detailed description of the new reports see the "Creating diamond reports" section in the manual
6. The new cut Radiant was added

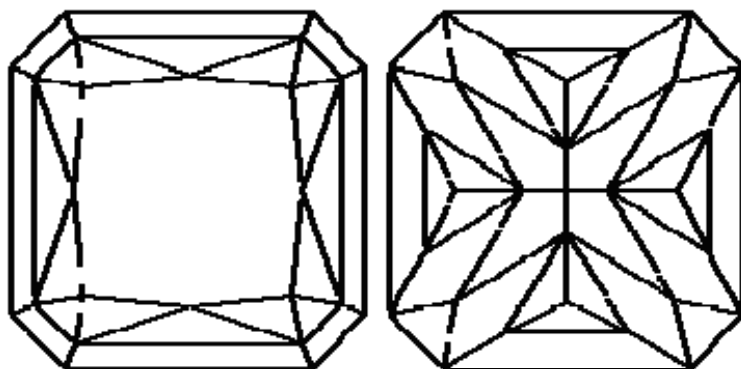

7. Restored the red-blue stereo mode (menu View / Stereo mode ON)

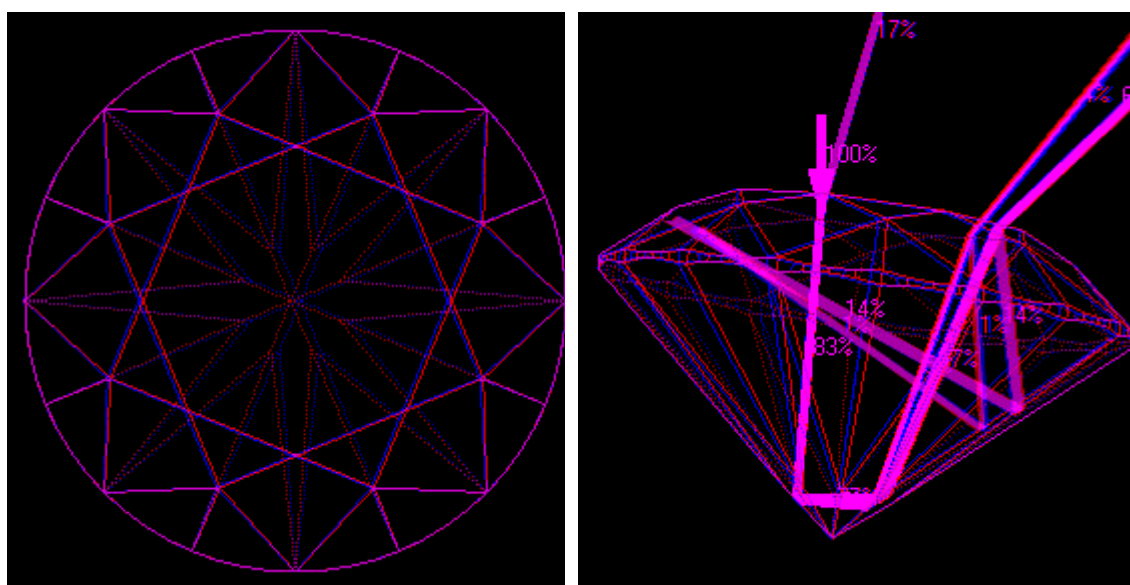

8. Added special lighting for better viewing of the photoreal images in red-blue stereo mode (menu Options / Special view / Red-blue stereo). This is just



another lighting, which may be turned on in usual mono mode, as well as any other lighting may be turned on in red-blue stereo mode. The settings for this lighting are picked up in such a way, so as to make the perception of the 3D effect of the photoreal image of the model easier

9. Other cut quality results became slightly different also. Two years ago we began to develop a new visualization algorithm that would take into account the finite dimensions of the eye aperture, depth resolution, astigmatism, etc. This is necessary for correct estimation of Scintillation and Fire. We need to switch to another model of light propagation for it. This work is not finished yet, but we have included one of our intermediate results in this version. Our tests showed that the new program simulates the photo much better in cases when the ray leaves the diamond at an angle close to critical. We have done it more than half a year ago and have not announced it till now, because we hoped to finish the work completely. As it turns out we need at least half a year more, so we decided to make a partial upgrade of the modeling algorithm right now
10. The default quality of photoreal image calculation for round shape is increased. The number of ray reflections for pattern calculation is set to 4, for intensity calculation is set to 30, the same as for fancy shapes
11. The IdealScope lighting settings are corrected

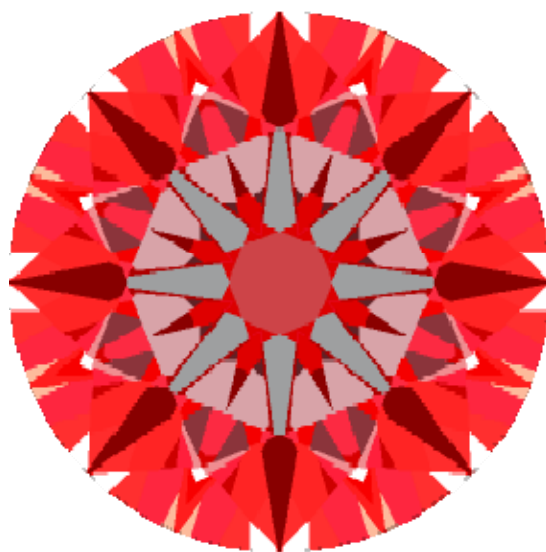

DiamCalc 2.2.1

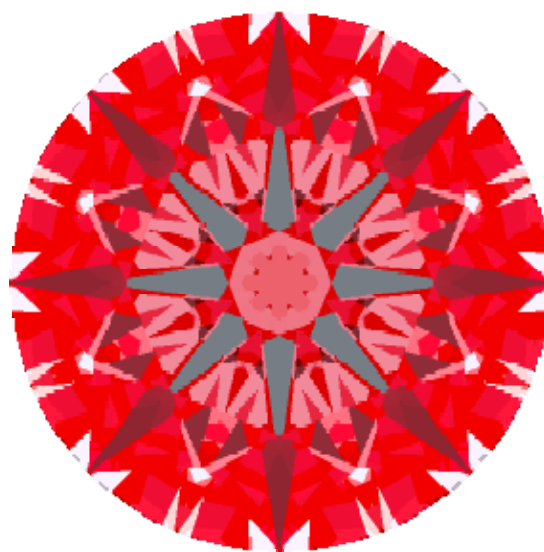

DiamCalc 2.3.0

12. The lightings **HA Table** and **HA Pavilion** are combined into one **Hearts & Arrows**. Now turning on the **Hearts&Arrows** lighting does not change the simulation parameters and does not rotate the stone. Use **Top view** and **Bottom view** buttons to view the stone from the table and pavilion sides



Top view



Bottom view

13. Import from TXT file with parameters recognizes two additional parameters: Star Facets, Lower Facets. See SampleImport.txt for example
14. Added possibility to export arbitrary convex model to GemCad ASCII format
15. The format of DiamCalc DMC files for scanned cuts was changed to enable advanced cut editing. Consequently, the format of GemAdviser GEM files was changed also
16. The background color for photoreal image is taken from the lighting settings. Different splitted views use different light sources. The background may be of any color and is displayed using the monitor settings (gamma)
17. The background color for draft models is not connected to lightings
18. The background picture is not removed when the background color is changed. Added a new menu item for removing the background picture
19. Added command **Batch processing** to the menu Cut. It allows converting a series of files from Sarin SRN format into GemAdviser GEM format
20. Added command to movie menu that allows appending of the movie to existing one. Load the first movie as usual; use "Append" command of the Options – Animation – Movie menu to choose another movie file for appending. The second movie should have the same quantity of frames, the same vertical size of the frame and the same color depth as the first movie. It is recommended to use true-color movies for this operation. If movies have 8 bits color depth, the palette of the first movie is used
21. Side azimuths are displayed in the range of [0; 360] degrees
22. Status line shows the current frame size
23. In the ray tracing mode the status line shows the current mode (Power/Intensity) and the wave length for which the values over the rays are drawn
24. Added button **Bottom view** to the toolbar
25. Added option **Always on top** to the menu View
26. The cut Heart was corrected and updated

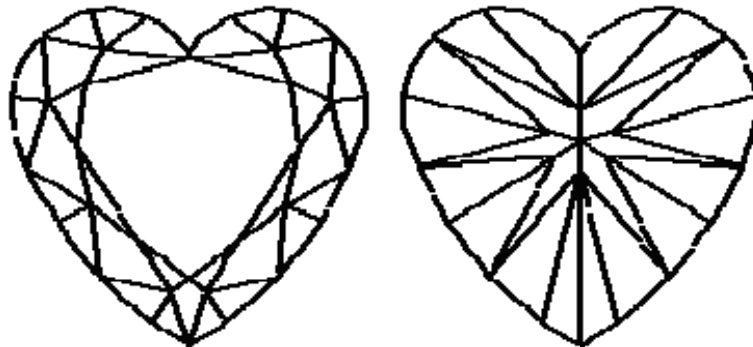

### Fixed bugs

- Fixed girdle thickness AGS appraiser. It uses parameter Girdle Height measured in percents now instead of millimeters.
- The parameter Lower facet was removed from all appraisers except **Russian**.
- The lighting **Incandescent lamp** now switches off correctly.
- The lighting **Firescope** sets the lens parameters to definite correct values.
- When the **Smart bright** mode in the lighting was enabled, it was impossible to switch to draft view.
- Some simulation parameters were not saved in DMC file, like eye color adaptation, lens parameters, special view settings used for evaluation of fish eye, light leakage, light return and contrast. Fixed saving of simulation parameters to DMC file.
- Fixed setting of "Prism" cut parameters.
- The button of the "Fish Eye" parameter in cut quality estimation now shows a short description.
- Fixed import of cuts.
- Fixed import from DXF format – the resulting cut was mirrored.
- Fixed import from the GemCad ASCII format. The cuts with clockwise direction of gear teeth and non-zero bottom index are imported correctly now.
- If the file already existed during movie export to AVI file it was not truncated to new size.
- If the generated movie has 8 bits per pixel, it is converted to 24 bits per pixel during its export to AVI without compression, because standard movie player does not playback movies with 8 bpp.
- The DiamCalc did not clear its window contents during movie playback which could lead to garbage on screen.
- Fixed drawing of the model in the Word report. Now all models are drawn exactly the same as they are drawn on screen after using Top view and Bottom view buttons on toolbar.
- Minor fixed in Word report template.
- Fixed highlighting of sides in the model.
- The menu item **Prices** shows checkmark when the prices are shown.



### **15.5 Updated appraiser file Apprice.txt - April 23, 2003**

The DiamCalc appraiser for the AGS system performs the girdle thickness estimation incorrectly. (It was configured to perform girdle thickness estimation similar to GIA data but the AGS has different rules for girdle estimation). The correct data for AGS girdle estimation is included now in the updated appraiser file. If you need quick solution for this problem then please replace the older [appraise.txt](#) file in the DiamCalc folder with this new one: Appraise.txt, otherwise you may want to wait until the next DiamCalc release that will include this fix.

Another known issue about the appraisal is that the DiamCalc data for GIA estimation of girdle thickness entered as percentage or mm value is valid only for diamonds of size from 3.80 mm to 8.25 mm, for the diamonds out of this range DiamCalc gives incorrect GIA estimation of the girdle thickness (this issue doesn't apply to girdle thickness entered as word description). This issue will be fixed by the end of the May 2003.

### **15.6 DiamCalc 2.2.1 (build 265) - March 7, 2003**

Fixed bug: in the version 2.2.1 (build 255) in the GemCad ASCII files import panel crown, pavilion and girdle parameters were frozen and displayed value 0.

### **15.7 DiamCalc 2.2.1 (build 255) - February 25, 2003**

#### **New features**

1. The Emerald cut has two additional parameters (on the Advanced 2 tab) that define cutting of the rectangle corners: **Corner facets** and **Corner facets ratio**
2. Import from TXT file with parameters recognizes additional parameter: second diameter. See SampleImport.txt for example
3. Zoom in/zoom out commands may be invoked by rotating the mouse wheel
4. When the user chooses one of the predefined lightings the photoreal visualization automatically turns on if it wasn't activated already
5. The FAQ section is added to the Diamond Calculator user manual
6. During import from PACOR MMD files all non-convex facets are triangulated to guarantee that all imported facets are convex

#### **Fixed bugs**

- The position of the observer's head is visualized correctly now in the mode **multiple rays from eye**
- The parameter **Table diameter** in Princess cut works correctly now
- Consequent Zoom in and Zoom out commands does not change zoom factor now
- In some cases some facets of the model were not highlighted





- In some cases some parts of the ray in the ray tracing mode were not displayed properly
- When the model had significant displacement from the origin of coordinates in DXF file, this model was imported incorrectly
- During import from DXF, MMD, SRN files the orientation of the model is checked and if the table is not at the bottom, the whole model is turned upside-down
- The photorealistic image of the model was not scaled properly when saving it into file with high resolution

### **15.8 DiamCalc 2.2.0 (build 247) - December 10, 2002**

#### **New features**

1. Export of the generated movie into AVI format using the codec selected by user. This command is available in the movie menu on the toolbar, or in the main menu (Options / Animation / Movie / Export to AVI)
2. Non-spatial animation in movies. The movie may be generated by changing diamond parameters (crown and pavilion angles). This feature is available through the path type menu on the toolbar, or through the main menu (Options / Animation / Figure / Reverse Crown vs. Pavilion, Direct Crown vs. Pavilion, Crown variation, Pavilion variation, OctoNus-MSU Crown vs. Pavilion)
3. The **Movie recording options** dialog box provides a possibility to set the step of animation figure parameters change when applicable
4. Added option **Reset diamond to table-up position at movie start** to the **Movie recording options** dialog box. It allows to preserve the current diamond orientation and to start the spatial animation from the chosen position or from the table-up position
5. Added option **Draw diamond wire-frame profile in the corner** to the **Movie recording options** dialog box. It allows to lay the diamond wire-frame profile on the movie frames during recording to illustrate how the diamond parameters (crown and pavilion) change
6. In the ray-tracing mode the spatial animation takes into consideration options for objects rotation (rays, diamond or both)
7. Added the possibility to load JPEG images as background (Options / Background color / Picture / Set picture)
8. The background picture is now placed in the center after load by default. The background is easier to move now to match the current diamond model (Options / Background color / Picture / Adjust position)
9. The estimation of cut quality may be interrupted (Cut quality tab / Start/Stop estimation button)
10. Added 6 informative parameters for the brilliant cut describing details of the crown and pavilion angles. They are useful when dealing with diamonds that have deviations from ideal round girdle shape (Angles details tab)
11. Added the possibility to view and save graphical illustration of the map of current light sources to the file (Options / Advanced / Lighting map)

- 
12. Added brain picture options to the Head and eyes configuration dialog (Options / Advanced / Lighting configuration / Observer / Head and eyes)
  13. Added import of 3D models obtained with the PACOR-Oxygen diamond scanner (Cut / Import cut / From PACOR data file)
  14. Added import of text files containing cut parameters. For the format of these files see SampleImport.txt file (Cut / Import cut / From TXT file with parameters)
  15. Added help describing some aspects of cut quality estimation (Help / Help Topics, or click on **Explain brilliance** label on the Cut quality tab)

### Bugs fixed

- If the selected background color differed from black, then adjusting the position of the background picture caused corruption of the solid background
- When saving an image of the current model with the background picture set in a high resolution, the background picture was not zoomed accordingly
- Setting of the standard light or changing the observer parameters corrupted the "Distance between eyes" parameter set by the user

### **15.9DiamCalc 2.1.1 (build 216) - August 22, 2002**

Dear Madam/Sir,

Please, read this information carefully. This letter contains the detailed information about an error in installation kits of our software dated by July 2002: **DiamCalc 2.1 (build 216) and GemCalc 1.1 (build 216)** available on our site from the July 28, 2002 till the August 18, 2002 and instructions how to eliminate influence of this error on the normal work of the operating system on your computer. If did not download ether of the files listed above or you have only Windows XP operating system installed on your computer, there is no need to read further.

For everyone who downloaded versions of DiamCalc or GemCalc software dated by July 2002 from our site we recommend to update the MSVCRT.DLL that should be in the WINDOWS/SYSTEM or WINNT/SYSTEM32 folder. It is better to take this DLL library from the distribution kit of your operating system. Please replace this DLL library as soon as possible and before the reboot of the system.

**If your Windows fails to start then PLEASE DO NOT REINSTALL WINDOWS. There is no need to reinstall Windows, the only thing you need is to update one file.**

If you can't get this file from distribution kit of your operating system, you may download it from the web-page of our site:

The [MSVCRT.DLL](#) for the Windows 98 and WinNT operating system. File version 6.00.8797.0. It should be placed into Windows/System folder on Windows 98 and WinNT/System32 on Windows NT.

The [MSVCRT.DLL](#) for the Windows 2000 operating system. File version 6.10.8924.0. It should be placed into WinNT/System32 folder.

**If you don't know how to replace the file, please contact us and tell us the version of your operating system.**



We would do our best to help you (even if your Windows does not start). Here is the cause of the problem and possible consequences. The latest installation of our software accidentally included one system file from Windows XP. When you run the installation on the previous version of Windows it replaced this file (msvcrt.dll) with the new version. After that all applications that somehow used this system library refused to work. This reveals as the following error message when trying to load such a program: "The MSVCRT.DLL file is linked to missing export NTDLL.DLL: RtlGetNtVersionNumbers" If you have some programs that are loaded automatically at the system startup you may encounter such an error right after the system boot or system fails to start (this possible, for example, with some anti-virus software). YOU SHOULD NOT REINSTALL Windows even it doesn't start. You just need to update msvcrt.dll file. If the Windows doesn't start then you can update file through the command prompt or emergency repair disk.

The following Microsoft article describes that procedure for Window 98 and Me:

<http://support.microsoft.com/default.aspx?scid=KB;EN-US;q299296>

**If you fail to replace the file or don't know how to, then please contact us**

Please don't hesitate to contact us if you encountered any problems. **We deeply regret that we didn't prevent such a vexatious error that may give you a lot of trouble and lead to the waste of time.**

In the latest software release we've changed the software architecture to preclude a possibility of such problems in future.

We apologize that we informed you of this error with such a delay.

Please, contact us if you encountered this error.

### **15.10DiamCalc 2.1.0 - July 28, 2002**

- Adjust cut parameters with shapes [imported from GemCad ASCII files](#) (available only in the registered version).
- A flexibility of the built-in parametric shapes applies now to shapes imported from GemCad ASCII file. With the DiamCalc 2.1 you can now change the crown height, pavilion depth and girdle height along with the size.

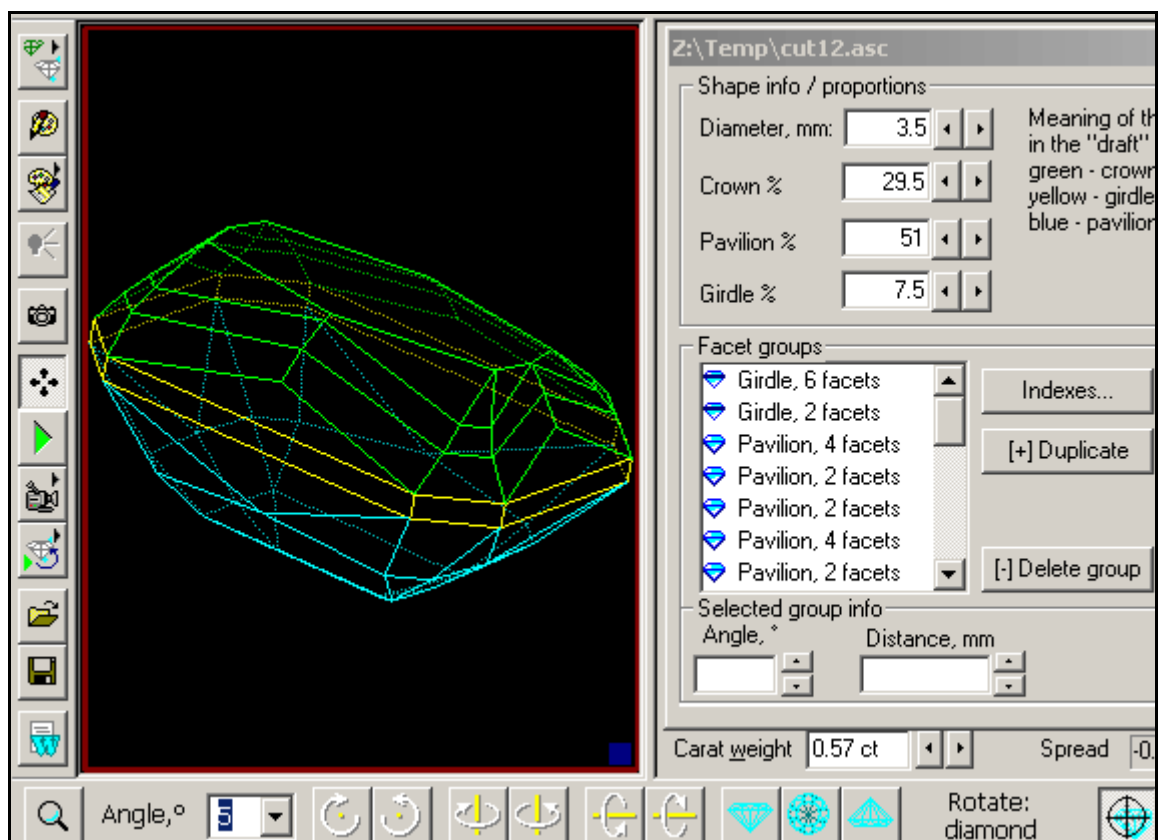

- New lighting models: **GemCad ISO**, **GemCad ISO** + observer head blockage, **GemCad COS**, **GemCad COS** + observer head blockage.

### 15.11DiamCalc 2.0.1 - May 25, 2002

- [Spread](#) indication is available (only for the registered version);
- Incorrect picture saving with resolutions 72, 300 & 600 dpi - now is fixed;
- Multiple ray tracing mode with imported cuts showed the only one ray - now is fixed.

### 15.12DiamCalc 2.0 - March 15, 2002

- Quantitative estimation some features of the round diamond cut: [Light Return](#), [Light Leakage](#), [Fish Eye](#) and [Contrast](#), based on a diamond 3D model (registered version only).
- Export to GemAdviser software format. The DiamCalc 2.0 has a possibility to save the certain diamond in the GemAdviser .gem format. You can send this file to your customers by e-mail, put on your website or deliver by any other means allowing your customer or partner to open this file with a [free GemAdviser software](#). With the GemAdviser software your customer can get an idea of the diamond appearance ("photo realistic" rendering mode and animated picture with diamond tilting in different directions) and to make a preliminary conclusion about the cut quality.

- [Import of the real diamond 3D models](#) generated with the [Sarin](#) machines (Sarin Web Viewer files). This allows you to work with the 3D-model of REAL DIAMONDS. As opposed to the parametrical models based only on the angles and other cut parameters obtained from diamond report, this feature gives you the REAL 3D-model of certain diamond based on the information about EVERY FACET of this diamond. A number of diamonds with attached .srn data is available for [RapNet](#) users.



- Support of the [DXF format](#). DXF Import: this feature allows you to use cut designs saved with this format. You can find a couple of free cut designs saved with this format at <http://www.3dlapidary.com>
- Support of the DXF format. DXF Export: this allows you to export any diamond you have in the DiamCalc (including all kind imported cut) to AutoDesk drawing exchange format (DXF) supported by many 3D software packages including AutoCad, 3D Studio MAX etc.
- [Working with different types of gemstones](#). This allows you to work not only with diamonds, but with different gemstone types including colored gems.
- Advanced options for ray tracing view: multiple rays from eye including scaled view showing an observer, intensity and power display for the partial rays.

### **15.13DiamCalc 1.8.0 - 1.8.3, July 2001 - January 2002**

- The new ray tracing mode **Multiple rays from eye**
- Different presentations of the girdle thickness, crown height and pavilion depth corresponding to different places of measurements (girdle valley or bezel facets)
- Indication of information about a facet (slope and azimuth) when move cursor over it
- Different presentations of the girdle thickness, crown height and pavilion depth corresponding to different places of measurements (girdle valley or bezel facets)

### **15.14DiamCalc 1.7.0 - 1.7.5, July 2000 - March 2001**

- The new feature Ray tracing allows users to see how the ray of light travels through the diamond. With the menu Options / Model type / Ray trace you can activate ray tracing mode ([full description](#)).

- Lighting model is modified to represent light sources with the physical dimensions and location;
- Added material dissipation and additional modes for photorealistic image simulation (See Lighting configuration / Simulation parameters).

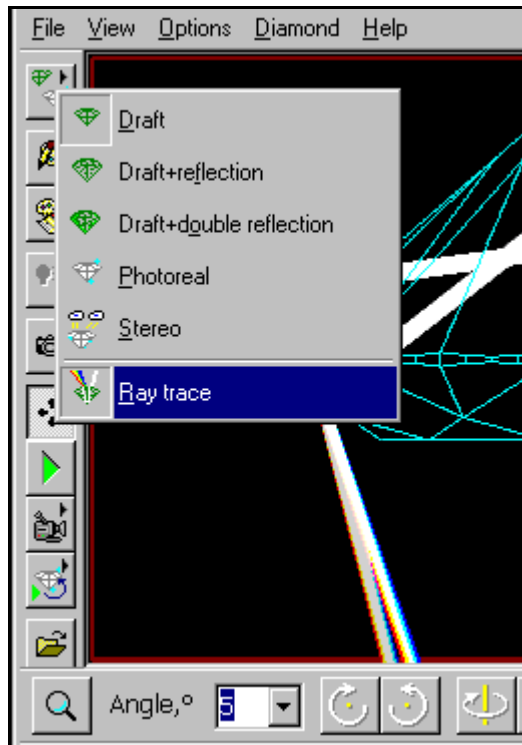

- Record movies with 8-bit color depth (this allows to decrease a movie size by 3 times).
- Zoom of the diamond image.
- [Corrected Firescope simulation](#);
- New algorithm of color conversion from XYZ to RGB (monitor colors). The new pictures are more saturated and realistic;
- New lighting configuration "Disco" added.
- In the DiamCalc 1.7 all save/load functions are disabled in demo version.

### **15.15DiamCalc 1.6.0 - 1.6.1, April - May 2000**

- Import diamond shapes feature allows the registered users to import diamond shapes from [GemCad](#) ASCII files and see its appearance. With the [DataVue2](#) library you can see over 3700 unique faceting designs. Open File / Import diamond menu to begin using this feature.

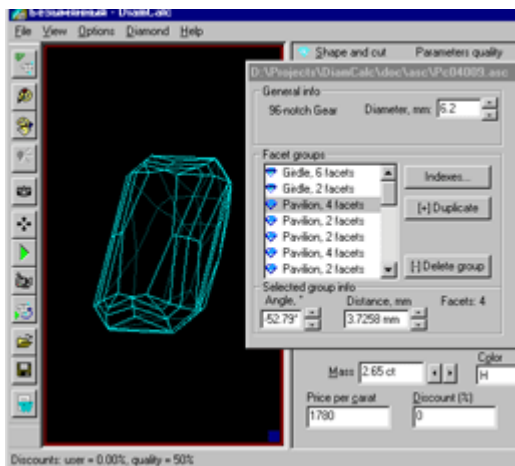

Here you can find examples of ASCII files with faceting designs: download [example1](#) (1Kb), [example2](#) (1Kb) or both examples in zip-file: [asc\\_samp.zip](#) (1Kb).

- Record and play movie feature is a major improvement in diamond display a moving image of the diamond allowing a dramatic view of the diamond's scintillation and sparkle. This new feature and several other new additions to DiamCalc capabilities enhance its use in both research in diamond cut design and use in displaying to a customer the brilliance, fire, and sparkle of well cut diamonds. This movie feature is fully integrated into the other advanced features of DiamCalc, so that the moving diamond image may be observed under all the varied and special lighting conditions supplied with the program.

Open Options / Animation menu or just click on the **camera** button to begin using this feature



### 15.16 DiamCalc 1.5.0 - 1.5.1, March - April 2000

- Added interface for learning and customizing lighting environment that allows users to create their own configurations suitable for modeling almost all real life lighting environments
- Save and load customized lighting configurations and extra simulation parameters
- New **Office** lighting

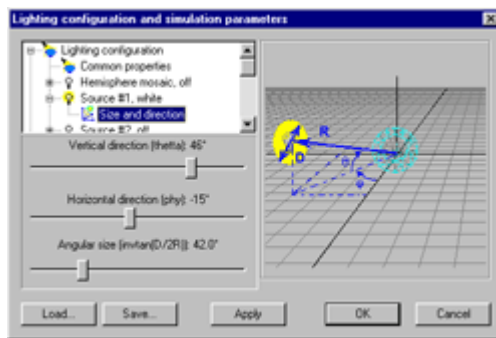

### 15.17DiamCalc 1.4

- High resolution simulated diamond pictures
- New view modes with specific structured lighting: Diascope, Firescope, Al Gilbertson (color rings) and etc



Diascope

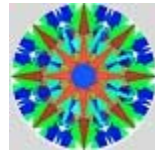

Al Gilbertson



FireScope



Jewelry shop

### 15.18DiamCalc 1.3

- AGS appraising
- Corrected *overall* grade determination in AGA appraising
- MS Word 2000 support
- Saving picture in JPEG format
- New **fixed cuts** for round brilliant shape

### 15.19DiamCalc 1.2

- Automatic diamond report generation with MS Word 95/97;
- **Fixed cuts** - some standard proportions, including Tolkowsky, Parker cuts and etc.

### 15.20DiamCalc 1.1

- Fixes in price list and appraising
- Registration via Internet
- [On-line documentation](#)

## 16 System Requirements

Please test you GPU (Graphics hardware) with **DiamCalc – Graphics Compatibility Evaluator utility** <http://www.octonus.com/oct/download/files/grcompevalsetup.exe>. This utility will attempt to render a reference data set in order to check if your Graphics hardware is compatible with new OctoNus HDR rendering engine. Please notice: even if you get negative test result the non-HDR rendering still available in DiamCalc3. Most of existing windows computers is compatible with non-HDR OctoNus rendering engine, though you can test it with DiamCalc demo available on download page: [http://www.octonus.com/oct/download/diam\\_demo\\_down.phtml](http://www.octonus.com/oct/download/diam_demo_down.phtml)

<b>Operating system</b>	Microsoft Windows*
<b>Computer and processor</b>	Personal computer with an Intel Pentium 233 MHz or faster processor is requirement. Intel Core 2 class is advisable. for fast calculation of photorealistic images.
<b>Memory</b>	128 megabytes (MB) of RAM minimum. 1 GB recommended.
<b>Hard disk</b>	25 megabytes (MB) of available hard-disk space.
<b>Display</b>	High-color Super VGA (800 x 600 x 16bit) or higher-resolution monitor.
<b>Video card</b>	VGA card with OpenGL support. To enable HDR rendering NVIDIA GeForce 6600 or higher, ATI X1300 or higher are required. We recommend to use at least NVIDIA GeForce 6800, ATI X1600.
<b>Other</b>	Microsoft Mouse or compatible pointing device; Microsoft Word 97 or later installed for viewing and printing reports; Anaglyphic red-blue glasses for viewing red-blue stereo images.

**\*Notice for Windows XP Pro x64 users:** The DiamCalc3 version for long hasp keys works only with 32-bit versions of Windows. The DiamCalc3 version for short hasp key supports Windows XP Pro x64.



## 17 Information for Mac users

DiamCalc software is developed for Windows so you cannot install and use it directly in Mac OS. Nevertheless there is a way you can use the DiamCalc on **Intel Mac**.

1. The MacOS version 10.5 has the **BootCamp** software <http://www.apple.com/macosx/features/bootcamp.html> which allows you to install Windows on your Mac on a separate partition. *The Windows license and installation media are not included with the MacOS/BootCamp. You have to obtain a copy of Microsoft Windows yourself*

Boot Camp Assistant can be found in the utilities - it contains all necessary instruction on installation.

When you install the Windows with the BootCamp on your Intel Mac you already have an option to boot in the Windows and run GemAdviser like on ordinary PC computer, though the MacOS software and data are not available during the work in Windows, so this is a kind of inconvenience..

2. Next you can install the **Parallels desktop** software and then you can use the Mac OS and Windows on your Mac in the same time which is more convenient than just an option 1. To get more information about the Parallels desktop please visit [www.parallels.com](http://www.parallels.com)

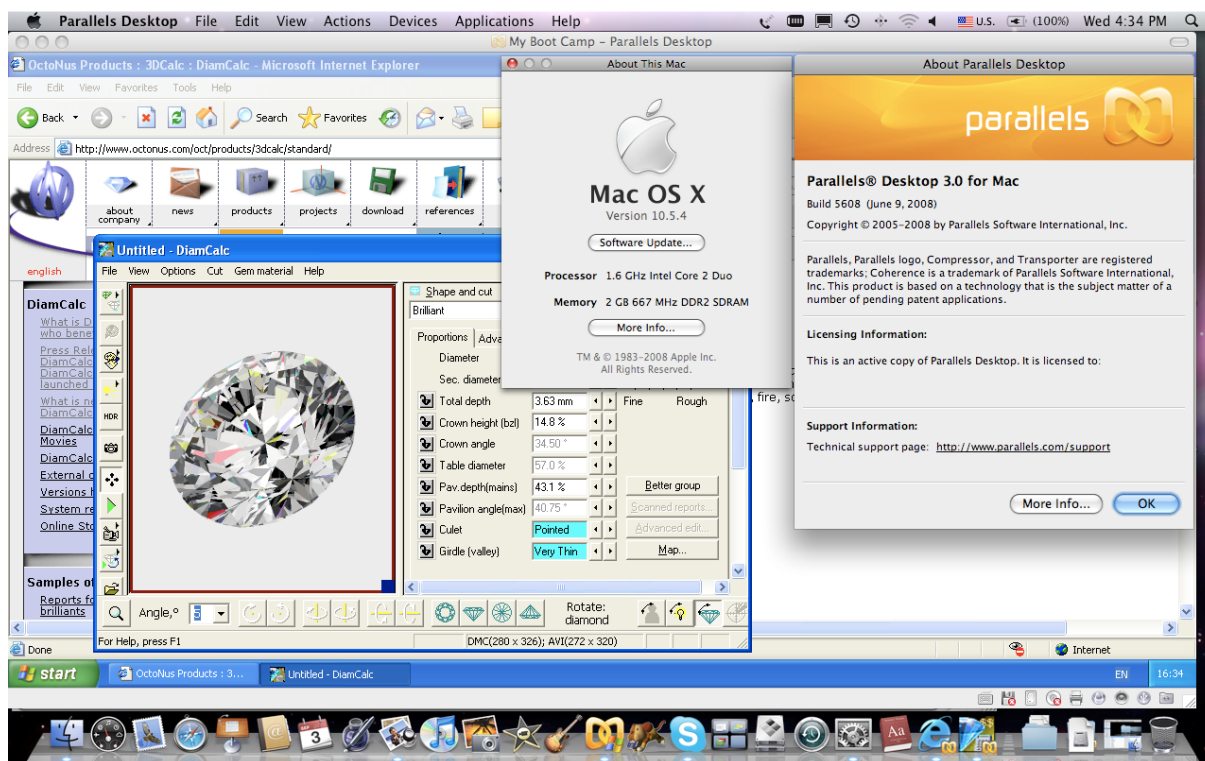



## 18 Appendix

For additional documentation on DiamCalc, refer to OctoNus Software Web pages. The main page of DiamCalc is <http://www.octonus.com/oct/products/3dcalc/standard/>. The OctoNus DiamCalc team wishes you great productivity from the new tools added to DiamCalc. We also welcome feedback and suggestions for improvements.